

TM 9-4120-425-14&P

TECHNICAL MANUAL

**OPERATOR'S, UNIT,
DIRECT SUPPORT AND
GENERAL SUPPORT
MAINTENANCE MANUAL**

**INCLUDING REPAIR PARTS
AND SPECIAL TOOLS LIST**

FOR

**AIR CONDITIONER,
HORIZONTAL, COMPACT,
36,000 BTU/HR,
208 VOLT,
THREE PHASE,
50/60 HERTZ**

**PART NO. S9500-36KH-1
NSN 4120-01-467-2638**

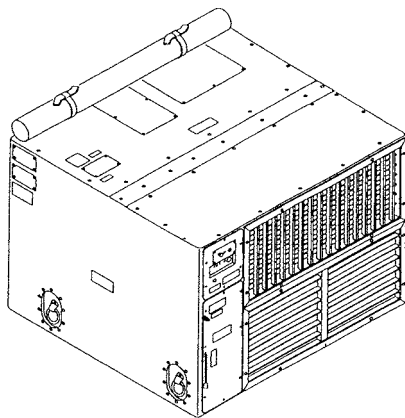

DISTRIBUTION STATEMENT A: Approved for public release; distribution is unlimited

**HEADQUARTERS, DEPARTMENT OF THE ARMY
1 OCTOBER 2002**

WARNING SUMMARY

This warning summary contains general safety warnings and hazardous materials warnings that must be understood and applied during operation and maintenance of this equipment. Failure to observe these precautions could result in serious injury or death to personnel.

WARNING

Do not use steam, open flame, heat gun, or any other high temperature source to thaw an iced coil. Thaw an iced coil by operating unit in HEAT mode, or by leaving unit shut down until ice melts.

WARNING

Compressed air used for cleaning purposes will not exceed 30 psi (2.1 kg/cm²). Do not direct compressed air against skin. Use goggles or full face shield.

WARNING

Avoid inhaling fumes from acid formed by burn out of oil and refrigerant. Wear a air filtering mask (Item 29, Table 1, WP 0121-00) if area is not thoroughly ventilated. Wear protective goggles or glasses to protect eyes. Wear rubber gloves to protect hands. Use care to avoid spilling compressor burn out sludge. If sludge is spilled, clean area thoroughly.

WARNING

Clean parts in a well-ventilated area. Avoid inhalation of solvent fumes and prolonged exposure of skin to cleaning solvent. Wash exposed skin thoroughly. Dry cleaning solvent, P-D-680 Type III, used to clean parts is potentially dangerous to personnel and property. Avoid repeated and prolonged skin contact. Do not use near open flame or excessive heat. Flash point of solvent is 100°F to 138°F (38°C to 59°C).

WARNING

DEATH ON CONTACT or severe injury may result if personnel fail to observe safety precautions. Always disconnect the air conditioner from power source before performing maintenance on this equipment. Make sure equipment is grounded at all times. If power must remain on for troubleshooting, exercise extreme care to avoid contact with any electrical component, fan, fan motor, etc.

WARNING SUMMARY - Continued

WARNING

Whenever possible, input power supply to the equipment must be shut off before beginning work. Take particular care to discharge capacitor likely to hold a dangerous potential charge. Refer to WP 0122-00 Schematic Diagram (Capacitor C1).

WARNING

Do not operate equipment without all grilles, guards, louvers, and covers in place and tightly secured.

WARNING

Use a mechanical lift to prevent physical injury.

WARNING

Unit contains R-22 a chemical substance which harms public health and the environment by destroying ozone in the upper atmosphere, and that the equipment is to be serviced by qualified personnel only.

WARNING

For safe operation the air conditioner must be grounded prior to use.

WARNING

In the event that first aid is required for injured operating or maintenance personnel, refer to FM 21-11 for proper first aid procedures.

WARNING

Ensure that the correct voltage and phase to phase power connections are made. Compressor damage may occur.

LIST OF EFFECTIVE PAGES

INSERT LATEST CHANGED PAGES, DESTROY SUPERSEDED PAGES

NOTE: The portion of the text affected by the changes is indicated by a vertical line in the outer margins of the page. Changes to illustrations are indicated by miniature pointing hands. Changes to schematic diagrams are indicated by shaded areas.

Dates of issue for original and changed pages are:

Original..... 1 October 2002

TOTAL NUMBER OF PAGES FOR FRONT AND REAR MATTER IS 19 AND TOTAL NUMBER OF WORK PACKAGES IS 122, CONSISTING OF THE FOLLOWING:

Page No.	* Change No.	Page No.	* Change No.	Page No.	* Change No.
Cover	0	WP0033 00 (5 pgs)	0	WP0073 00 (3 pgs)	0
a – b	0	WP0034 00 (7 pgs)	0	WP0074 00 (4 pgs)	0
A-B	0	WP0035 00 (8 pgs)	0	WP0075 00 (3 pgs)	0
i – iv	0	WP0036 00 (3 pgs)	0	WP0076 00 (6 pgs)	0
Chp 1 title page	0	WP0037 00 (3 pgs)	0	WP0077 00 (4 pgs)	0
WP0001 00 (4 pgs)	0	WP0038 00 (2 pgs)	0	WP0078 00 (4 pgs)	0
WP0002 00 (14 pgs)	0	WP0039 00 (2 pgs)	0	WP0079 00 (2 pgs)	0
WP0003 00 (3 pgs)	0	WP0040 00 (2 pgs)	0	Chp 9 title page	0
WP0004 00 (1 pg)	0	WP0041 00 (2 pgs)	0	WP0080 00 (1 pg)	0
Chp 2 title page	0	WP0042 00 (1 pg)	0	WP0081 00 (3 pgs)	0
WP0005 00 (2 pgs)	0	WP0043 00 (3 pgs)	0	Chp 10 title page	0
WP0006 00 (6 pgs)	0	WP0044 00 (2 pgs)	0	WP0082 00 (7 pgs)	0
WP0007 00 (3 pgs)	0	Chp 7 title page	0	Chp 11 title page	0
Chp 3 title page	0	WP0045 00 (1 pg)	0	WP0083 00 (1 pg)	0
WP0008 00 (2 pgs)	0	WP0046 00 (3 pgs)	0	WP0084 00 (2 pgs)	0
WP0009 00 (2 pgs)	0	WP0047 00 (7 pgs)	0	WP0085 00 (2 pgs)	0
WP0010 00 (2 pgs)	0	Chp 8 title page	0	WP0086 00 (2 pgs)	0
Chp 4 title page	0	WP0048 00 (3 pgs)	0	WP0087 00 (2 pgs)	0
WP0011 00 (4 pgs)	0	WP0049 00 (3 pgs)	0	WP0088 00 (2 pgs)	0
WP0012 00 (3 pgs)	0	WP0050 00 (3 pgs)	0	WP0089 00 (2 pgs)	0
Chp 5 title page	0	WP0051 00 (3 pgs)	0	WP0090 00 (2 pgs)	0
WP0013 00 (1 pg)	0	WP0052 00 (3 pgs)	0	WP0091 00 (2 pgs)	0
WP0014 00 (6 pgs)	0	WP0053 00 (3 pgs)	0	WP0092 00 (2 pgs)	0
Chp 6 title page	0	WP0054 00 (4 pgs)	0	WP0093 00 (4 pgs)	0
WP0015 00 (7 pgs)	0	WP0055 00 (2 pgs)	0	WP0094 00 (2 pgs)	0
WP0016 00 (7 pgs)	0	WP0056 00 (3 pgs)	0	WP0095 00 (2 pgs)	0
WP0017 00 (2 pgs)	0	WP0057 00 (3 pgs)	0	WP0096 00 (2 pgs)	0
WP0018 00 (2 pgs)	0	WP0058 00 (2 pgs)	0	WP0097 00 (4 pgs)	0
WP0019 00 (3 pgs)	0	WP0059 00 (2 pgs)	0	WP0098 00 (2 pgs)	0
WP0020 00 (2 pgs)	0	WP0060 00 (3 pgs)	0	WP0099 00 (3 pgs)	0
WP0021 00 (4 pgs)	0	WP0061 00 (2 pgs)	0	WP0100 00 (2 pgs)	0
WP0022 00 (2 pgs)	0	WP0062 00 (3 pgs)	0	WP0101 00 (11 pgs)	0
WP0023 00 (2 pgs)	0	WP0063 00 (4 pgs)	0	WP0102 00 (2 pgs)	0
WP0024 00 (2 pgs)	0	WP0064 00 (3 pgs)	0	WP0103 00 (2 pgs)	0
WP0025 00 (3 pgs)	0	WP0065 00 (3 pgs)	0	WP0104 00 (2 pgs)	0
WP0026 00 (2 pgs)	0	WP0066 00 (3 pgs)	0	WP0105 00 (2 pgs)	0
WP0027 00 (3 pgs)	0	WP0067 00 (5 pgs)	0	WP0106 00 (2 pgs)	0
WP0028 00 (4 pgs)	0	WP0068 00 (3 pgs)	0	WP0107 00 (2 pgs)	0
WP0029 00 (3 pgs)	0	WP0069 00 (3 pgs)	0	WP0108 00 (2 pgs)	0
WP0030 00 (1 pg)	0	WP0070 00 (3 pgs)	0	WP0109 00 (2 pgs)	0
WP0031 00 (1 pg)	0	WP0071 00 (3 pgs)	0	WP0110 00 (2 pgs)	0
WP0032 00 (4 pgs)	0	WP0072 00 (4 pgs)	0	WP0111 00 (2 pgs)	0

TM 9-4120-425-14&P

LIST OF EFFECTIVE PAGES - Continued

WP0112 00 (2 pgs)	0	WP0117 00 (1 pg)	0	WP0122 00 (3 pgs)	0
WP0113 00 (3 pgs)	0	WP0118 00 (5 pgs).....	0	Chp 12 title page	0
WP0114 00 (1 pg).....	0	WP0119 00 (2 pgs).....	0	Index (3 pgs)	0
WP0115 00 (3 pgs)	0	WP0120 00 (1 pg)	0		
WP0116 00 (11 pgs)	0	WP0121 00 (3 pgs).....	0		

**OPERATOR'S, UNIT, DIRECT SUPPORT AND
 GENERAL SUPPORT MAINTENANCE MANUAL
 INCLUDING REPAIR PARTS AND SPECIAL TOOLS LIST**

FOR

**AIR CONDITIONER
 HORIZONTAL, COMPACT, 36,000 BTU/HR,
 208 VOLT,
 THREE PHASE,
 50/60 HERTZ**

**PART NO. S9500-36KH-1
 NSN 4120-01-467-2638**

REPORTING ERRORS AND RECOMMENDING IMPROVEMENTS

You can help improve this manual. If you find any mistakes, or if you know of a way to improve the procedures, please let us know. Mail your letter, DA Form 2028 (Recommended Changes to Publications and Blank Forms) or DA Form 2028-2 located in back of this manual direct to: Commander, U.S. Army Communications-Electronics Command and Fort Monmouth, ATTN: AMSEL-LC-LEO-D-CS-CFO, Fort Monmouth, New Jersey 07703-5006. The fax number is 732-532-1413, DSN 992-1413. You may also e-mail your recommendations to AMSEL-LC-LEO-PUBS-CHG@mail1.monmouth.army.mil. In any case we will send you a reply.

TABLE OF CONTENTS

	<u>WP Sequence No.</u>
CHAPTER 1 – INTRODUCTORY INFORMATION WITH THEORY OF OPERATION	
General Information	0001-00
Description and Data	0002-00
Theory of Operation	0003-00
Supporting Data for Repair Parts, Special Tools, TMDE, and Support Equipment	0004-00

CHAPTER 2 – OPERATOR INSTRUCTIONS	
Air Conditioner Control and Indicators	0005-00
Air Conditioner Operation Under Usual Conditions	0006-00
Air Conditioner Operation Under Unusual Conditions	0007-00

CHAPTER 3 – OPERATOR TROUBLESHOOTING PROCEDURES	
Operator Troubleshooting Introduction	0008-00
Operator Malfunction/Symptom Index	0009-00
Operator Troubleshooting Procedures	0010-00

TABLE OF CONTENTS - Continued

	<u>WP Sequence No.</u>
CHAPTER 4 – OPERATOR MAINTENANCE INSTRUCTIONS	
Operator Preventive Maintenance Checks and Services	0011-00
Operator Maintenance Instructions	0012-00

CHAPTER 5 – UNIT TROUBLESHOOTING	
Unit Troubleshooting Introduction	0013-00
Unit Troubleshooting	0014-00

CHAPTER 6 – UNIT MAINTENANCE INSTRUCTIONS	
Unit Maintenance Service Upon Receipt	0015-00
Unit Preventive Maintenance Checks and Services (PMCS)	0016-00
Unit Maintenance Mechanical Repairs and Electrical Repairs	0017-00
Canvas Cover – Services	0018-00
Panels – Unit Maintenance	0019-00
Evaporator Louvers – Unit Maintenance	0020-00
Condenser Air Discharge Louvers – Unit Maintenance	0021-00
Ventilation Guard and Ventilation Air Filter – Unit Maintenance	0022-00
Evaporator Air Intake Filter – Unit Maintenance	0023-00
Condenser Coil Guard – Unit Maintenance	0024-00
Information Plates – Unit Maintenance	0025-00
Mist Eliminator – Unit Maintenance	0026-00
Heater Cutout Switches – Unit Maintenance	0027-00
Heater Subassembly – Unit Maintenance	0028-00
Condensate Drain Assembly – Unit Maintenance	0029-00
Evaporator Fan Motor – Unit Maintenance	0030-00
Condenser Fan Motors – Unit Maintenance	0031-00
Louver Actuator Cables – Unit Maintenance	0032-00
Circuit Breaker – Unit Maintenance	0033-00
Remote Control Module – Unit Maintenance	0034-00
Junction Box Assembly – Unit Maintenance	0035-00
Transformer – Unit Maintenance	0036-00
Terminal Boards TB1 and TB5 – Unit Maintenance	0037-00
Unit Wiring – Unit Maintenance	0038-00
Coil (Solenoid Valve) – Unit Maintenance	0039-00
Evaporator Coil – Unit Service	0040-00
Condenser Coil – Unit Service	0041-00
Housing – Unit Service	0042-00
Main Power Input Connector – Unit Maintenance	0043-00
Installation Hardware – Unit Maintenance	0044-00

CHAPTER 7 – DIRECT SUPPORT TROUBLESHOOTING PROCEDURES	
Direct Support Troubleshooting Introduction	0045-00
Direct Support Malfunction/System Index	0046-00
Direct Support Troubleshooting Procedures	0047-00

TABLE OF CONTENTS - Continued

WP Sequence No.

CHAPTER 8 – DIRECT SUPPORT MAINTENANCE PROCEDURES

Refrigeration System Description	0048-00
Refrigeration System Servicing – (Discharging).....	0049-00
Refrigeration System Servicing – (Purging).....	0050-00
Refrigeration System Servicing – (Brazing/Debrazing).....	0051-00
Refrigeration System Servicing – (Leak Test)	0052-00
Refrigeration System Servicing – (Evacuation)	0053-00
Refrigeration System Servicing – (Charging)	0054-00
Refrigeration System Servicing – (Pressure Testing).....	0055-00
Condensate Drain Assembly Direct Support Maintenance	0056-00
Evaporator Fan Assembly Direct Support Maintenance	0057-00
Evaporator Impeller Fans Direct Support Maintenance Replacement.....	0058-00
Evaporator Fan Scrolls Direct Support Maintenance Replacement.....	0059-00
Evaporator Fan Motor Direct Support Maintenance Replacement.....	0060-00
Evaporator Motor Bracket and Chassis Direct Support Maintenance Replacement	0061-00
Condenser Impeller Fans and Motors Direct Support Maintenance Replacement	0062-00
Condenser Fan Scrolls Direct Support Maintenance Replacement	0063-00
Condenser Fan Support Direct Support Maintenance Replacement.....	0064-00
Ventilation Damper Direct Support Maintenance	0065-00
Dehydrator (Filter-Drier) Direct Support Maintenance Replacement	0066-00
Solenoid Valves and Hot Gas By-Pass Valve Direct Support Maintenance Replacement.....	0067-00
Damper Actuator Cylinder Direct Support Maintenance Replacement.....	0068-00
Receiver Direct Support Maintenance Replacement	0069-00
Pressure Relief Valve Direct Support Maintenance Replacement.....	0070-00
Accumulator Direct Support Maintenance Replacement	0071-00
Pressure Switches Direct Support Maintenance Replacement	0072-00
Service Valves Direct Support Maintenance Replacement	0073-00
Expansion Valve Direct Support Maintenance Replacement.....	0074-00
Liquid Sight Indicator Direct Support Maintenance Replacement.....	0075-00
Compressor Direct Support Maintenance Replacement	0076-00
Evaporator Coil Direct Support Maintenance Replacement.....	0077-00
Condenser Coil Direct Support Maintenance Replacement	0078-00
Tubing and Fittings Direct Support Maintenance Replacement.....	0079-00

CHAPTER 9 – GENERAL SUPPORT MAINTENANCE INSTRUCTIONS

General Support Maintenance	0080-00
Housing General Support Maintenance.....	0081-00

CHAPTER 10 – REPAIR PARTS AND SPECIAL TOOLS LIST (RPSTL)

Introduction	0082-00
Frontispiece – Air Conditioner, Horizontal, Compact, 36,000 BTU/HR, 208 Volt, Three Phase, 50/60 Hertz.....	0083-00
Figure 1. Canvas Cover	0084-00
Figure 2. Identification Plates.....	0085-00
Figure 3. Panels and Covers	0086-00
Figure 4. Evaporator Air Louvers, Air Conditioning Filter and Mist Eliminator.....	0087-00
Figure 5. Condenser Exhaust Louvers, Condenser Coil Guard, Ventilation Air Filter and Guard.....	0088-00
Figure 6. Condenser Air Exhaust Louver Assembly (Left).....	0089-00
Figure 7. Condenser Air Exhaust Louver Assembly (Right).....	0090-00
Figure 8. Condensate Drain.....	0091-00
Figure 9. Evaporator Fan Assembly	0092-00
Figure 10. Condenser Fan.....	0093-00
Figure 11. Louver Actuator Cables	0094-00

TABLE OF CONTENTS - Continued

WP Sequence No.

CHAPTER 10 – REPAIR PARTS AND SPECIAL TOOLS LIST (RPSTL) - Continued

Figure 12. Ventilation Damper	0095-00
Figure 13. Heater Subassembly	0096-00
Figure 14. Circuit Breaker	0097-00
Figure 15. Remote Control Module.....	0098-00
Figure 16. Junction Box	0099-00
Figure 17. Terminal Boards.....	0100-00
Figure 18. Unit Wiring	0101-00
Figure 19. Dehydrator (Filter-Drier).....	0102-00
Figure 20. Solenoid Valves	0103-00
Figure 21. Damper Actuator Cylinder.....	0104-00
Figure 22. Receiver and Pressure Relief Valve	0105-00
Figure 23. Accumulator.....	0106-00
Figure 24. Pressure Switches and Service Valves	0107-00
Figure 25. Evaporator Coil and Expansion Valve	0108-00
Figure 26. Liquid Sight Indicator	0109-00
Figure 27. Condenser Coil.....	0110-00
Figure 28. Tubing and Fittings	0111-00
Figure 29. Compressor	0112-00
Figure 30. Housing	0113-00
Bulk Materials List	0114-00
National Stock Number Index	0115-00
Part Number Index	0116-00

CHAPTER 11 – SUPPORTING INFORMATION

References	0117-00
Maintenance Allocation Chart For 36,000 BTU Air Conditioner	0118-00
Component of End Item (COEI) and Basic Issue Items (BII) Lists	0119-00
Additional Authorization List (AAL).....	0120-00
Expendable and Durable Items List.....	0121-00
Schematic Diagram	0122-00

CHAPTER 12 – REAR MATTER

Alphabetical Index

CHAPTER 1

**INTRODUCTION INFORMATION WITH
THEORY OF OPERATION**

**AIR CONDITIONER, COMPACT, HORIZONTAL,
GENERAL INFORMATION**

0001-00

SCOPE

a. Type of Manual: Operator, Unit, Direct and General Support Maintenance Including Repair Parts and Special Tools List.

b. Part Number and Equipment Names: S9500-36KH-1
Air Conditioner, Compact, Horizontal, 36,000 BTU/HR, 208 Volt, Three Phase, 50/60 Hertz.

c. Purpose of Equipment: The air conditioner is used primarily in van type enclosures to provide filtered, cooled or heated air, as required to maintain the service conditions necessary for the efficient operation of electronic equipment in the vans. The air conditioner also provides for the comfort of operating personnel housed within the vans.

CONSOLIDATED INDEX OF ARMY PUBLICATIONS AND BLANK FORMS

Refer to the latest issue of DA PAM 25-30 to determine whether there are new additions, changes, or additional publications pertaining to the equipment.

MAINTENANCE FORMS, RECORDS, AND REPORTS

a. Reports of Maintenance and Unsatisfactory Equipment. Department of the Army forms and procedures used for equipment maintenance will be those prescribed by DA PAM 738-750, as contained in Maintenance Management Update.

b. Reporting of Item and Packaging Discrepancies. Fill out and forward SF 364 (Supply Discrepancy Report (SDR)) as prescribed in AR 735-11-2/DLAR 4140.55/SECNAVINST 4355.18/AFR 400-54/MCO 4430.3J.

c. Transportation Discrepancy Report (TDR) (SF 361). Fill out and forward Transportation Discrepancy Report (TDR) (SF 361) as prescribed in AR 55-38/NAVSUPINST 4610.33C/AFR 75-18/MCO P4610.19D/DLAR 4500.15.

DESTRUCTION OF ARMY ELECTRONICS MATERIAL

Destruction of Army electronics material to prevent enemy use shall be in accordance with TM 750-244-2.

ADMINISTRATIVE STORAGE

Administrative storage of equipment issued to and used by Army activities will have Preventive Maintenance Checks and Services (PMCS) performed before storing. When removing the equipment from administrative storage, the PMCS checks should be performed to assure operational readiness.

REPORTING EQUIPMENT IMPROVEMENT RECOMMENDATIONS (EIR)

If your 36K air conditioner needs improvement, let us know. Send us an EIR. You, the user, are the only one who can tell us what you don't like about your equipment. Let us know why you don't like the design or performance. Put it on an SF 368 (Product Quality Deficiency Report). Mail it to: Commander, US Army Communications-Electronics Command, Fort Monmouth, New Jersey 07703-5006, ATTN: AMSEL-LC-LEO-D-CS-CFO. We'll send you a reply.

CORROSION PREVENTION AND CONTROL (CPC)

Corrosion Prevention and Control (CPC) of Army materiel is a continuing concern. It is important that any corrosion problems with this item be reported so that the problem can be corrected and improvements can be made to prevent the problem in future items.

While corrosion is typically associated with rusting of metals, it can also include deterioration of other materials, such as rubber and plastic. Unusual cracking, softening, swelling, or breaking of these materials may be a corrosion problem.

**AIR CONDITIONER, COMPACT, HORIZONTAL,
GENERAL INFORMATION - Continued**

0001-00

CORROSION PREVENTION AND CONTROL (CPC) - Continued

If a corrosion problem is identified, it can be reported using SF 368, Product Quality Deficiency Report. Use of key words such as "corrosion," "rust," "deterioration," or "cracking" will ensure that the information is identified as a CPC problem.

The form should be submitted to the address specified in DA PAM 738-750, Functional Users Manual for the Army Maintenance Management System (TAMMS).

DESTRUCTION OF ARMY MATERIEL TO PREVENT ENEMY USE

Refer to TM 750-244-3, Procedures for Destruction of Equipment to Prevent Enemy Use, for information about destruction.

PREPARATION FOR STORAGE AND SHIPMENT**Short Term Storage**

1. Disconnect power supply and remove from shelter.
2. Make sure unit is clean and dry.
3. Close all louvers and grilles.
4. Unroll canvas cover and snap into place.
5. Store in the operating (upright) position.

Long Term Storage

1. Disconnect power supply and remove from shelter.
2. Make sure unit is clean and dry. Blow-out condensate drains.
3. Close all louvers and grilles.
4. Unroll canvas cover and snap into place.
5. Package all hardware, cable connectors, technical manuals, etc. in a cushioned protective sack. Staple shut and secure to unit.

NOTE

Wrap cable connectors in cushioning material before packaging.

6. Seal all openings with polyethylene film and 1/2 inch pressure sensitive tape.
7. Cover the entire unit with a polyethylene film shroud and secure with 1/2 inch pressure sensitive tape.
8. Store air conditioner in a dry, dust-free space and in the operating (upright) position.
9. Storage of the air conditioner will be in accordance with TM 740-90-1, Administrative Storage of Equipment.

**AIR CONDITIONER, COMPACT, HORIZONTAL,
GENERAL INFORMATION - Continued**

0001-00

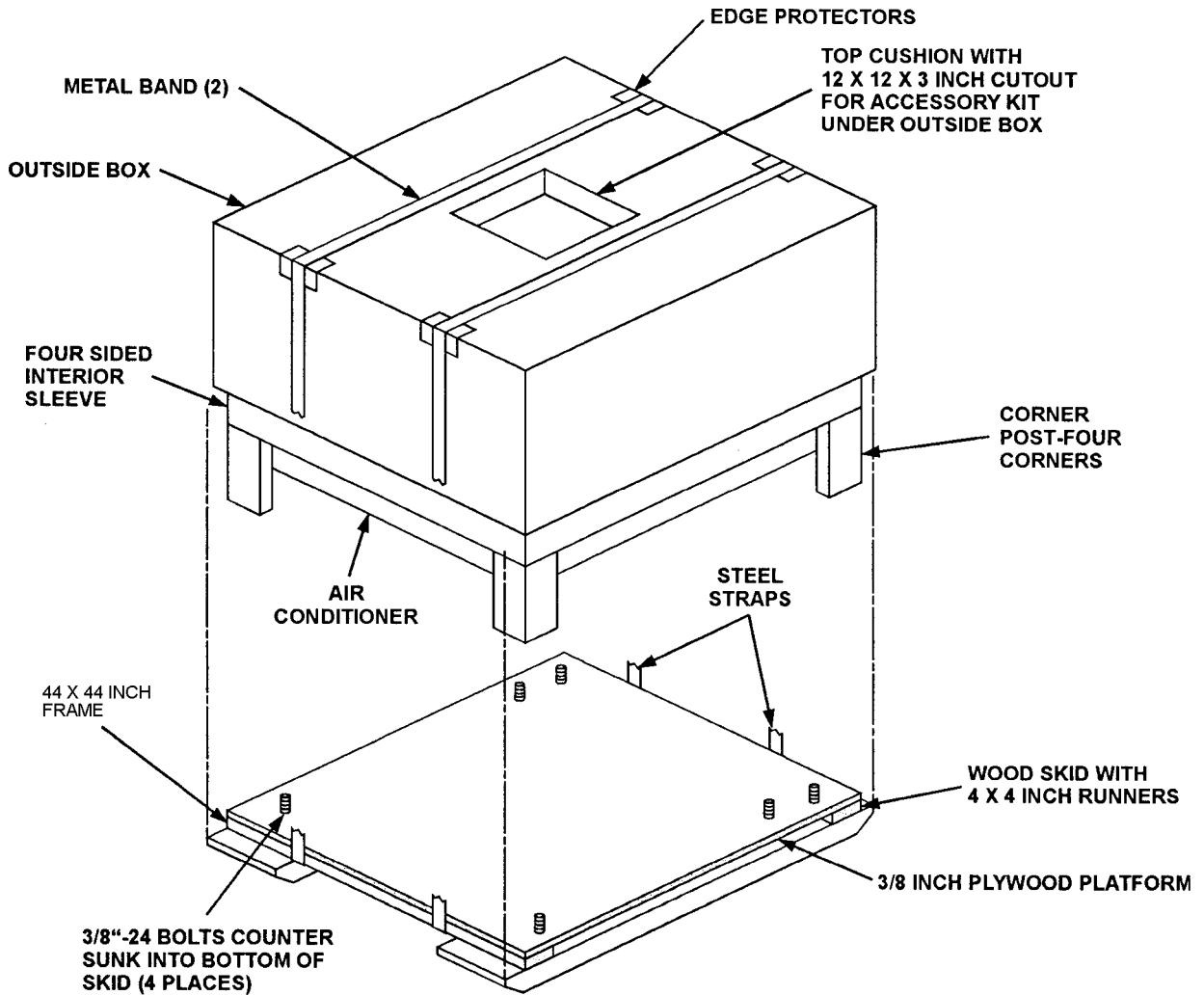
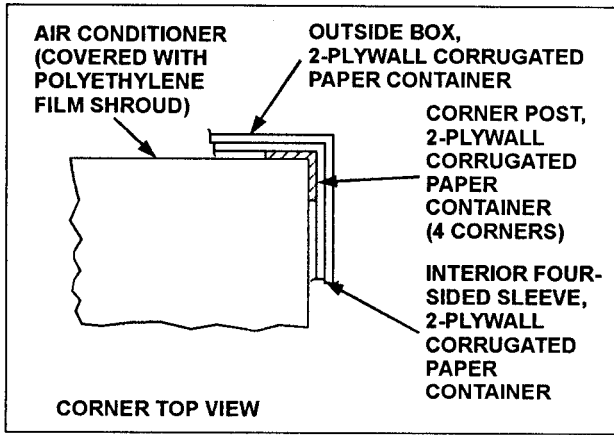

PACKING MATERIAL: 2 PLYWALL CORRUGATED PAPER
PACKING MATERIAL: 2 PLYWALL CORRUGATED PAPER

**AIR CONDITIONER, COMPACT, HORIZONTAL,
GENERAL INFORMATION - Continued**

0001-00

PREPARATION FOR STORAGE AND SHIPMENT - Continued**Preparation For Shipment**

Prepare unit as prescribed for long term storage.

Shipping Container

1. Fabricate a corrugated paper shipping container conforming to ASTM-D-3951-95 Level AB, Domestic Type. A minimum of 1-inch clearance will exist between the air conditioner and walls of the box. The box will be modified with skids located so that the bolts securing the air conditioner pass through the skids. Bolt heads will be countersunk into the bottom of the skids. The bolts with washers should protrude at least 3/8 inch above the skid and not more than 1/2 inch.
2. The air conditioner will be packed in the shipping container and secured to the skids with four bolts (3/8-24) and washers.
3. Wood spacers will be padded with water resistant cushioning material to prevent abrasion. Corner pads constructed of corrugated paper will be used on all top and bottom edges of the air conditioner.
4. The shipping container will be closed and secured with steel strapping material.
5. The air conditioner will be stored and shipped in the operating (upright) position. The words "THIS END UP" with arrows will be placed on each side of the shipping container. The letters will be black, at least 3 inches high, and located within the upper third of each side.

WARRANTY INFORMATION

The air conditioner is warranted for 60 months from the date of acceptance for the end item air conditioner. The warranty starts on the date found in block 23 of DA Form 2408-9, Equipment Control Record. Report all defects to your supervisor, who will take appropriate action.

NUCLEAR HARDNESS

All hardness critical procedures in this manual are marked with the acronym HCP as follows:

1. When an entire task including all paragraphs and procedures is considered hardness critical only the task title will be marked by the acronym HCP (placed before the title).
2. When only certain processes and steps within the work package are hardness critical, only the applicable processes and steps will be marked by placement of the acronym HCP between each applicable step number and the text.

END OF TASK

**AIR CONDITIONER, COMPACT, HORIZONTAL,
DESCRIPTION AND DATA**

0002-00

EQUIPMENT CHARACTERISTICS, CAPABILITIES AND FEATURES

The air conditioner provides filtered, cooled or heated air for efficient operation of electronic equipment in van type enclosures. It also provides comfort to operating personnel housed within the vans. The capabilities and features of the air conditioner are as follows:

- Light-weight, compact, horizontal.
- Wall/Floor-mounted and air-cooled.
- Electric motor driven and designed for continuous operation under varying loads.
- Furnishes 36,000 BTU/HR for cooling; 31,200 BTU/HR for heating.
- Handles for lifting.
- Alternate power input source.
- Roll-up canvas condenser cover.

LOCATION AND DESCRIPTION OF MAJOR COMPONENTS

COMPONENT	DESCRIPTION
1. Canvas Cover	Protects condenser coil from extreme cold temperatures during winter months.
2. Fresh Air Screen	Filter fresh (make-up) air for evaporator compartment.
3. Condenser Guard	Protects condenser from external damage.
4. Evaporator Air Intake Louver	Horizontal adjustable louver. Directs room air into air conditioner for filtering and recycling.
5. Evaporator Air Discharge Louver	Vertical and horizontal louvers. Individually hand adjustable. Directs conditioned air into room.
6. Charging Valve Access Cover	Provides entry for servicing refrigeration system.
7. Ventilation Damper Control	Opens and closes fresh air inlet passage.
8. Condensate Drain	Allows discharge of condensate during operation.
9. Control Module	Contains operator control switches.
10. Circuit Breaker Assembly	Protects unit from electrical current overload.
11. Liquid Sight Indicator	Indicates condition and level of refrigerant.
12. Main Input Power Connection (J2)	For connections to 208 volt, 50/60 Hz, three-phase power source.
13. Alternate Input Power Connector (J1)	Provides an alternate power input position. Refer to Schematic Diagram, WP 0122-00 for required wiring changes for use of connector in this location.
14. Ground Stud	Provides for auxiliary grounding connection.
15. Condenser Air Louvers	Adjustable louvers control amount of air available to cool condenser coil.

**AIR CONDITIONER, COMPACT, HORIZONTAL,
DESCRIPTION AND DATA - Continued**

0002-00

EQUIPMENT CHARACTERISTICS, CAPABILITIES AND FEATURES - Continued

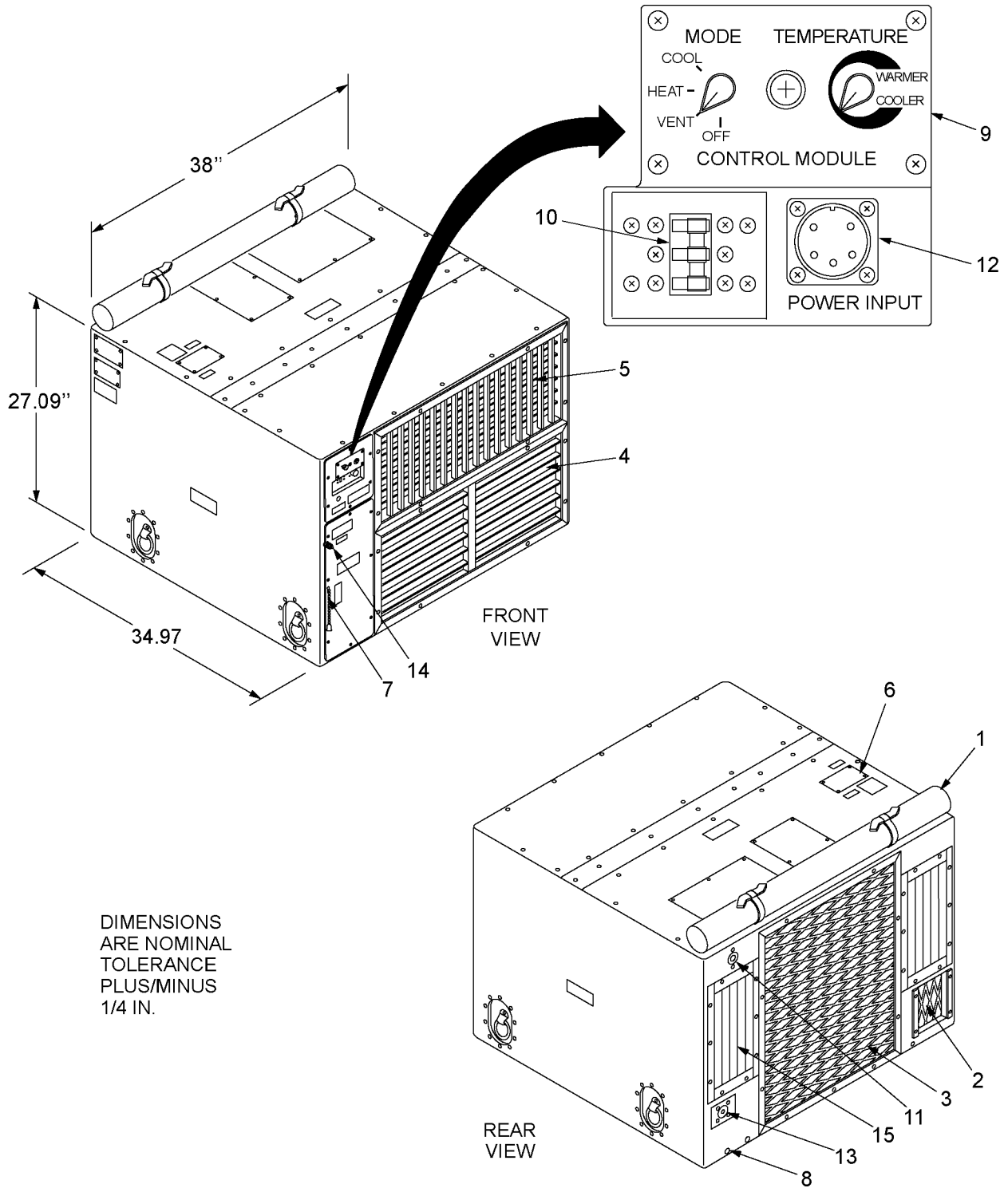

LOCATION AND CONTENTS OF IDENTIFICATION PLATES

Refer to the following list and illustration for each identification plate location as follows:

1. Identification Plate – indicates equipment data.
2. High Pressure Charging Valve Decal – locates charging valve.
3. Access Cover – marking identifying charging valve access cover.
4. Low Pressure Charging Valve Decal – locates charging valve.
5. Refrigeration Diagram – indicates refrigeration components.
6. Schematic Diagram – indicates electrical components & wiring.
7. Vent Decal – indicates fresh air vent position.
8. Grounding Lug Decal – locates grounding lug.
9. Caution: Grounding Decal – Reference to TM for grounding information.
10. Reset High Pressure Decal – indicates location of high pressure reset control.
11. Danger Decal – warning instructions on ground wire.
12. Lift Caution Decal – indicates requirements for moving unit; mechanical lift required (three places).
13. Warning Decal – environmental health warning on R-22.
14. Warranty Plate – indicates technical bulletin warranty program on air conditioner.
15. Caution Decal – 208 volts, disconnect power before maintenance.
16. Caution Decal – indicates to connect ground prior to turning the equipment on.
17. Remote Control Module Marking.

AIR CONDITIONER, COMPACT, HORIZONTAL,
DESCRIPTION AND DATA - Continued

0002-00

EQUIPMENT CHARACTERISTICS, CAPABILITIES AND FEATURES - Continued

LOCATION AND CONTENTS OF IDENTIFICATION PLATES - Continued

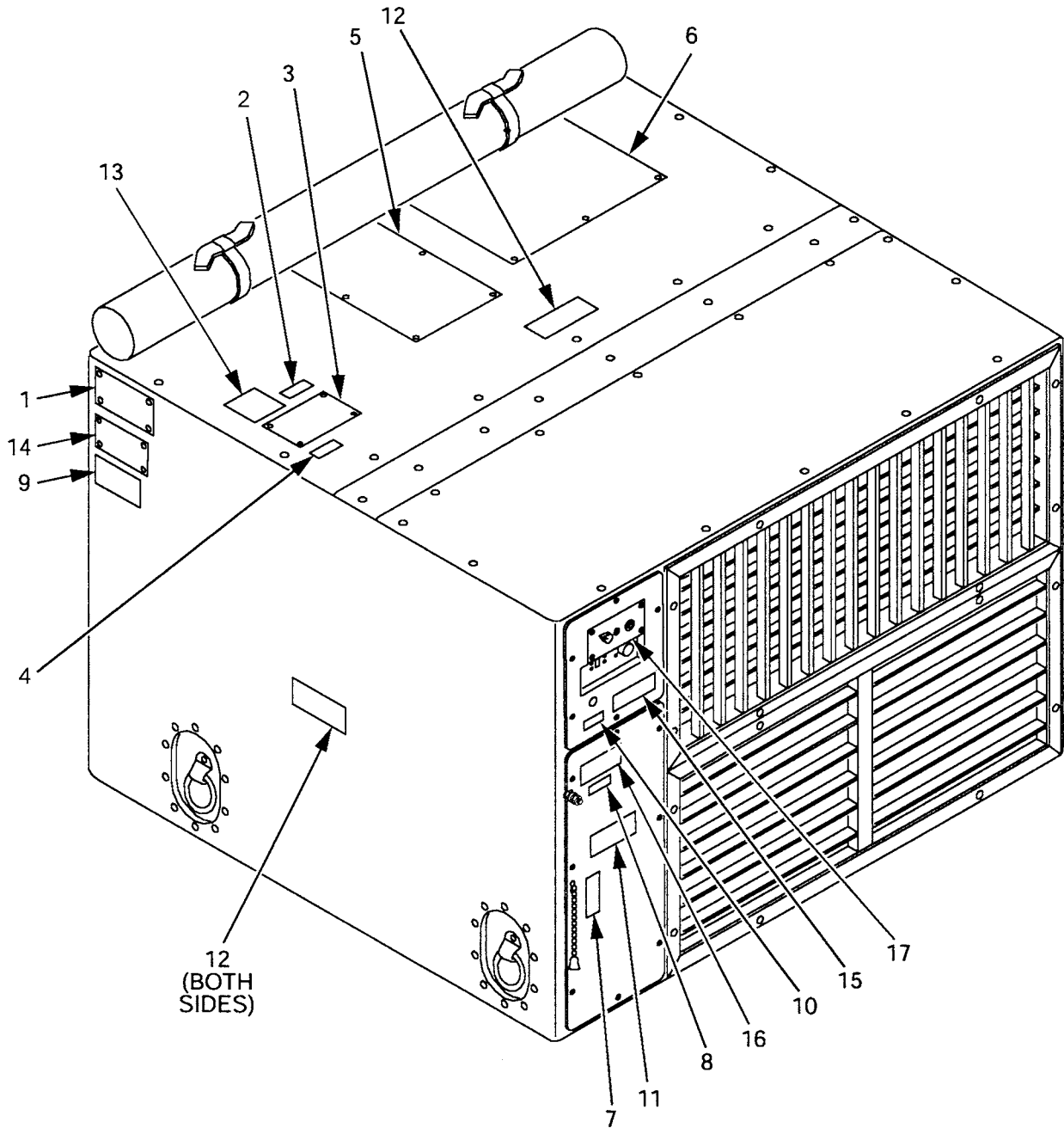

LOCATION AND CONTENTS OF IDENTIFICATION PLATES - Continued

U.S. ARMY	
AIR CONDITIONER 36,000 BTU/HR - HORIZONTAL, COMPACT 208 VOLT, 3 PHASE, 50/60 HZ	
NSN:	4120-01-467-2638
P/N:	S-9500-36KH-1
S/N:	<input type="text"/>
CONTRACT: DAAB07-99-D-D282-0001	
DATE OF MFG.:	<input type="text"/> WT: 420 LBS.
REFRIGERANT : R-22 CHARGE: 6 LBS.	
MFG. BY: ENVIRONMENTAL SYSTEMS, FL. FCSM:0V5R4	

Figure 1. Equipment Data Plate



Figure 2. High Pressure Charging Valve Decal

LOCATION AND CONTENTS OF IDENTIFICATION PLATES - Continued

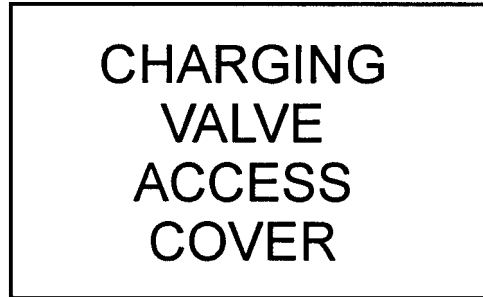
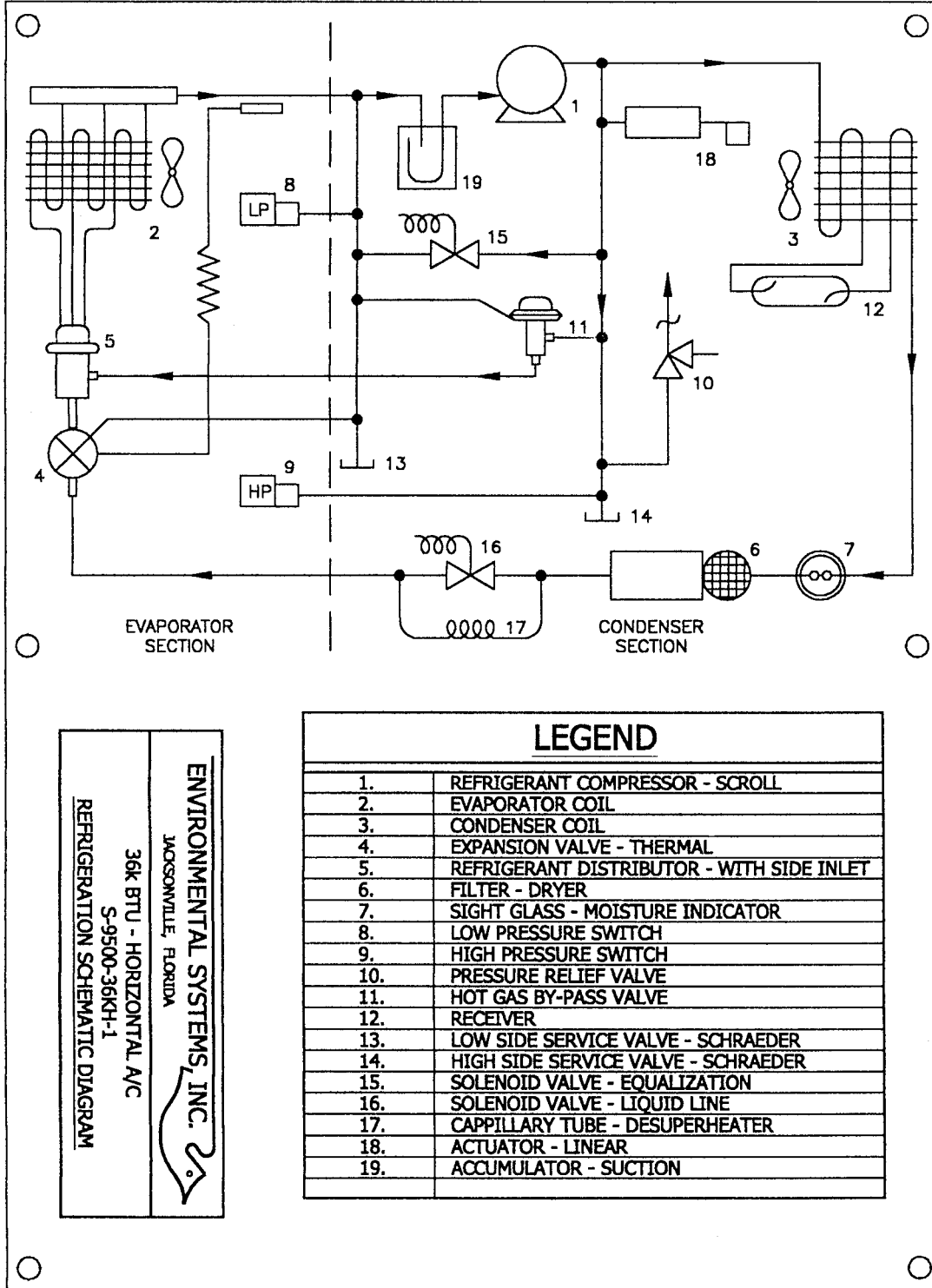

Figure 3. Access Cover Marking



Figure 4. Low Pressure Charging Valve Decal

LOCATION AND CONTENTS OF IDENTIFICATION PLATES - Continued



ENVIRONMENTAL SYSTEMS, INC.
 JACKSONVILLE, FLORIDA
 36K BTU - HORIZONTAL A/C
 S-9500-36KH-1
 REFRIGERATION SCHEMATIC DIAGRAM

Figure 5. Refrigeration Diagram Plate

LOCATION AND CONTENTS OF IDENTIFICATION PLATES – Continued

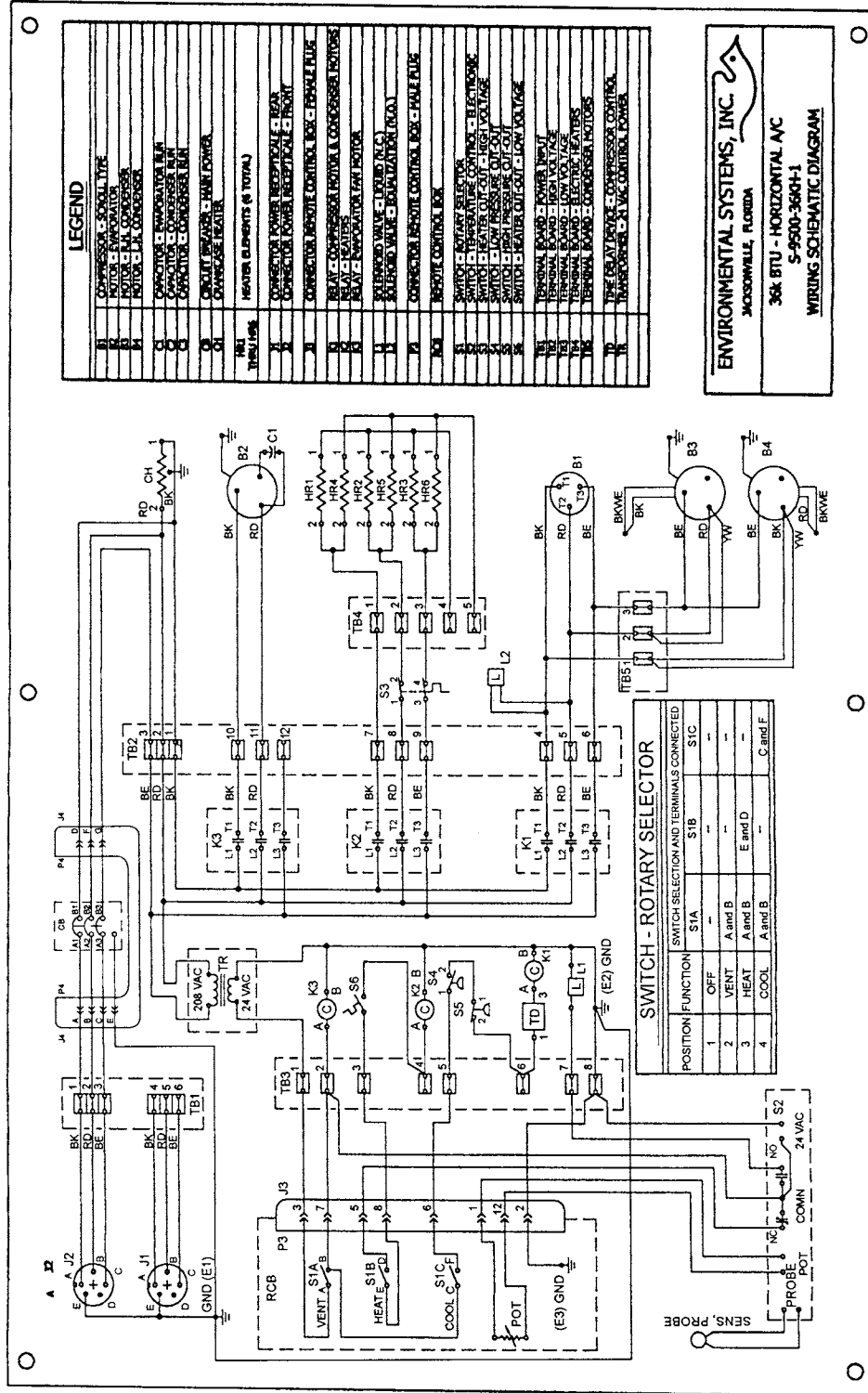

Figure 6. Schematic Diagram Plate

LOCATION AND CONTENTS OF IDENTIFICATION PLATES – Continued

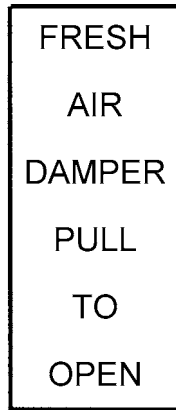

Figure 7. Vent Instruction Decal



Figure 8. Grounding Lug Decal

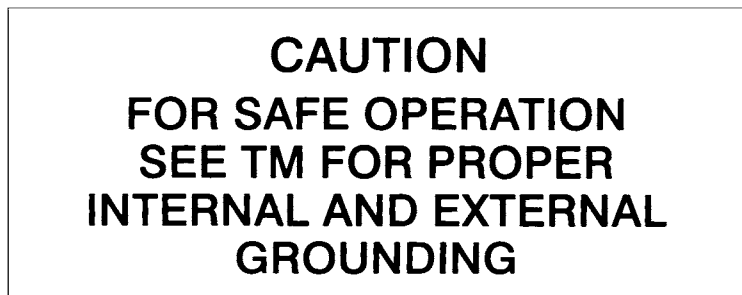

Figure 9. Caution – Grounding Decal

LOCATION AND CONTENTS OF IDENTIFICATION PLATES - Continued



Figure 10. Reset High Pressure Decal

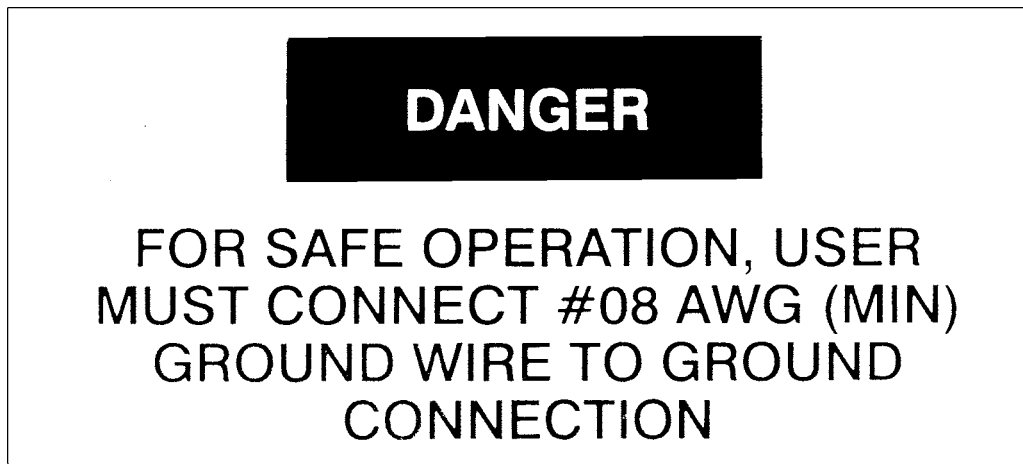

Figure 11. Danger Decal

LOCATION AND CONTENTS OF IDENTIFICATION PLATES - Continued

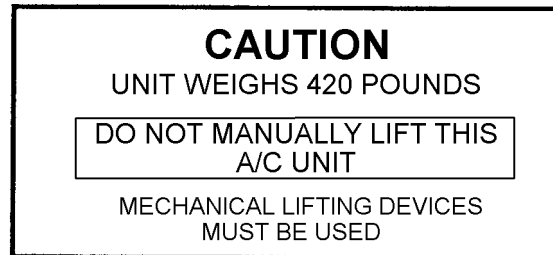

Figure 12. Lift Caution Decal

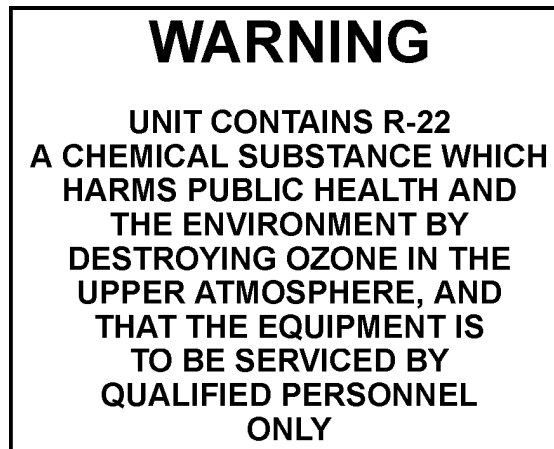

Figure 13. Warning Decal

LOCATION AND CONTENTS OF IDENTIFICATION PLATES - Continued

○	WARRANTY ITEM	○
	REFER TO	TM 9-4120-425-14&P
	EXPIRES	
		MO/YR
	CONTRACT NUMBER: DAAB07-99-D-D282-01	
○	The actual warranty is 60 months from date of acceptance or the date stamped above, whichever occurs first.	
		○

Figure 14. Warranty Plate

CAUTION - 208 VOLTS
BEFORE MAINTENANCE DISCONNECT POWER

Figure 15. Caution Decal

LOCATION AND CONTENTS OF IDENTIFICATION PLATES - Continued

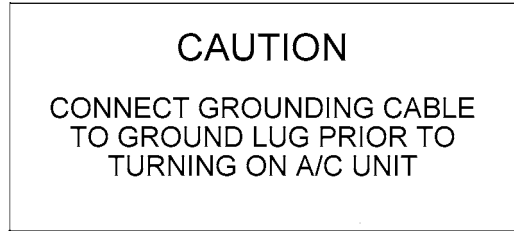

Figure 16. Caution Decal

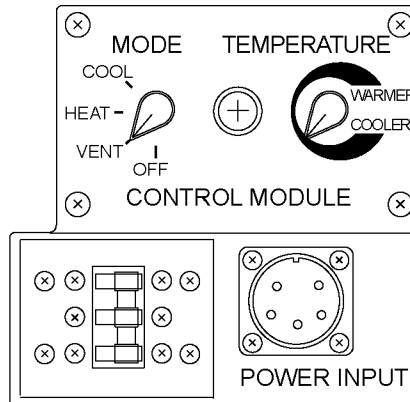

Figure 17. Remote Control Module Plate, Power Input Markings

**AIR CONDITIONER, COMPACT, HORIZONTAL,
DESCRIPTION AND DATA - Continued**

0002-00

EQUIPMENT DATA

Air Conditioner Part No. S9500-36KH-1

Nomenclature	Air Conditioner, Horizontal, Compact, 36,000 BTU/HR, 208 Volt, Three-Phase 50/60 Hertz
Manufacturer	Environmental Systems Corp. a Snowbird, ESC Company
Capacity:	
Cooling	40,000 BTU/HR (Nominal)
Heating	31,200 BTU/HR (Nominal)
Phase	Three
Hertz	50/60
A/C Volts	208 ± 10
Current input, full load, amperes:	
Cooling	28 (maximum)
Heat	33 (maximum)
Ventilating	7 (maximum)
Refrigerant	R22
Amount of Charge	6 lbs. 0 oz.
Dimensions and Weight	
Depth	35 inches (88.90 cm) Nominal
Height	27 inches (68.58 cm) Nominal
Width	38 inches (96.52 cm) Nominal
Evaporator Air Discharge Opening	28.25 inches x 12.04 inches (71.75 x 30.58 cm) Nominal
Evaporator Air Intake Opening	28.25 inches x 11.84 inches (71.75 x 30.07 cm) Nominal
Weight	398 pounds (maximum)
Operating Temperature Range	-50°F (-45°C) to +120°F (+49°C) HEATING +35°F (1.6°C) to +120°F (+49°C) COOLING

END OF TASK

TECHNICAL PRINCIPALS OF OPERATION**Refrigeration Cycle – Cooling (Refer to Schematic)**

The refrigeration system removes heat from a given area. The refrigeration cycle is as follows:

1. The compressor (1) takes cold, low pressure refrigerant gas and compresses it to a high temperature, high pressure gas. The gas flows through the copper tubing to the condenser coil (3) and receiver (12).
2. The condenser fan draws outside ambient air over and through the condenser coil (3). The high temperature, high pressure gas from the compressor (1) is cooled by the flow of air and is changed into a high pressure liquid.
3. The sight glass moisture indicator (7) indicates the presence of moisture and quantity of refrigerant in the system.
4. The filter-drier (6) removes any moisture (water vapor) or dirt that may be carried by the liquid refrigerant.
5. The expansion valve (4) senses the temperature and pressure of the refrigerant as it leaves the evaporator coil. By use of the remote bulb and "external equalizer line" the valve constantly adjusts the flow of liquid refrigerant to the evaporator coil (2).
6. As the high pressure liquid refrigerant leaves the expansion valve (4) and refrigerant distributor (5), it enters the evaporator coil (2) and "flashes" to a gas. This is due to the low pressure created in the evaporator by the compressor (1). The evaporator blower circulates the warm air, from the conditioned space, over and through the evaporator coil (2). Liquid refrigerant absorbs heat as it changes from a liquid to a gas. As the air flow from the conditioned space comes in contact with the evaporator coil (2) the air is cooled. If the air is cooled below its "dew point" moisture will condense on the evaporator coil (2) and be carried to the condensate drain. Thus providing both cooling and dehumidification.
7. The low pressure refrigerant gas is then drawn back through the accumulator (19) to the compressor (1) and the cycle is repeated.

Heating

When the MODE SELECTOR switch is set for HEAT, six (6) heating elements located behind the evaporator coil are energized. These elements are protected from overheating by a thermal cutout switch.

Refrigeration Cycle – Non-Cooling

In the "COOL" mode when the thermostat control senses return air to the unit below the thermostat set point the compressor and fans remain operating but the refrigeration cycle is altered to produce no net cooling to the controlled space. The refrigerant cycle is then as follows:

1. The high temperature-high pressure gas from the compressor (1) flows partly to the condenser and partly to the hot gas bypass valve (11).
2. The condenser fan draws outside ambient air over and through the condenser coil (3). The high temperature, high pressure gas from the compressor (1) is cooled by the flow of air and is changed into a high pressure liquid.
3. The hot gas bypass valve (11) regulates the flow of high temperature-high pressure gas to the evaporator (2) through the side inlet of the distributor (5) to maintain a prescribed evaporator pressure (approximately 50-55 psig).
4. The liquid line solenoid valve (16) having been de-energized by the thermostat control is closed diverting the flow of high pressure liquid from the condenser (3) through the desuperheater capillary tube (17).

TECHNICAL PRINCIPALS OF OPERATION - Continued

Refrigeration Cycle – Non-Cooling – Continued

5. The desuperheat capillary tube (17) restricts the flow of high pressure liquid to the expansion valve (4) to the proper amount to offset the high temperature of the gas from the hot bypass valve (11) to allow for cooling of the compressor (1). This results in only superheated low pressure gas flow through the evaporator coil (2) with little or no cooling effect.

6. The low pressure refrigerant gas is then drawn back through the accumulator (19) to the compressor (1) and the cycle is repeated.

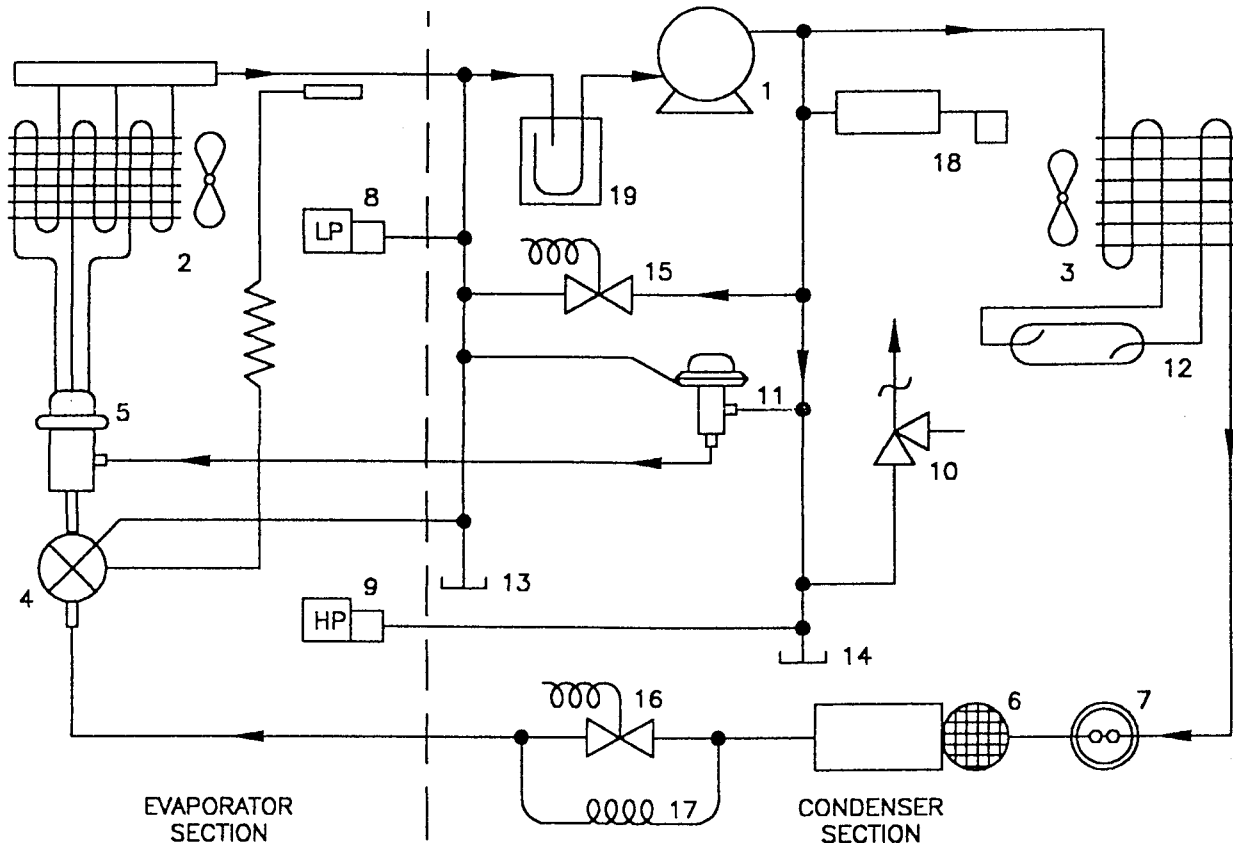

REFRIGERANT SCHEMATIC

LEGEND

1. REFRIGERANT COMPRESSOR – SCROLL
2. EVAPORATOR COIL
3. CONDENSER COIL
4. EXPANSION VALVE – THERMAL
5. REFRIGERANT DISTRIBUTOR – WITH SIDE INLET
6. FILTER – DRIER
7. SIGHT GLASS – MOISTURE INDICATOR
8. LOW PRESSURE SWITCH
9. HIGH PRESSURE SWITCH
10. PRESSURE RELIEF VALVE
11. HOT GAS BY-PASS VALVE
12. RECEIVER
13. LOW SIDE SERVICE VALVE – SHRAEDER
14. HIGH SIDE SERVICE VALVE – SHRAEDER
15. SOLENOID VALVE – EQUALIZATION
16. SOLENOID VALVE – LIQUID LINE
17. CAPILLARY TUBE – DESUPERHEATER
18. ACTUATOR – LINEAR
19. ACCUMULATOR – SUCTION

END OF TASK

**SUPPORTING DATA FOR REPAIR PARTS, SPECIAL TOOLS,
TMDE, AND SUPPORT EQUIPMENT**

0004-00

COMMON TOOLS AND EQUIPMENT

For authorized common tools and equipment, refer to the Modified Table of Organization and Equipment (MTOE), CTA 50-970, Expendable/Durable Items (Except: Medical, Class V, Repair Parts, and Heraldic Items), or CTA 8-100, Army Medical Department Expendable/Durable Items, as applicable to your unit.

SPECIAL TOOLS, TMDE, AND SUPPORT EQUIPMENT

No special tools and test equipment are required.

REPAIR PARTS

Repair parts are listed and illustrated in supporting information in Chapter 10 of this manual.

END OF TASK

CHAPTER 2
OPERATOR INSTRUCTIONS

DESCRIPTION AND USE OF CONTROLS AND INDICATORS

0005-00

GENERAL

The air conditioner is a self-contained and electric powered unit that provides 36,000 BTU/HR for cooling or 31,200 BTU/HR for heating. Once started, it operates automatically due to the relationship of the components, controls and instruments.

The air conditioner is designed for a variety of installations and for operation under a wide range of climactic conditions. It is also designed for continuous or intermittent operation as a self-contained unit. Operators must be aware of any peculiarities or operational limitations for their specific installation. See the appropriate shelter or system manual for instructions peculiar to your specific installation.

The air conditioner is not equipped with a CBR filter, however, the unit could be connected to external filtering equipment for operation under CBR environmental conditions.

OPERATOR'S CONTROLS

1. Cooling

With the MODE SELECTOR switch in COOL position, the fan motor is energized. The fan motor runs continuously. The temperature selector switch determines the cooling mode of unit. With the temperature selector switch calling for compressor operation, the liquid line solenoid valve opens and closes with the electronic thermostat switch to control the flow within the refrigerant circuit. The air conditioner is protected from current overload by a circuit breaker in the control module and a thermal overload in the compressor terminal cover.

2. Heating

With the MODE SELECTOR switch in the HEAT position, air is blown by the evaporator fan as in cooling, but the heating elements are energized instead of the refrigeration system.

3. Ventilation

Placing the MODE SELECTOR switch in the VENT position energizes the evaporator fan motor which forces air out of the evaporator discharge louver into the room. The amount of outdoor air used for ventilation is determined by the position of the ventilation damper door.

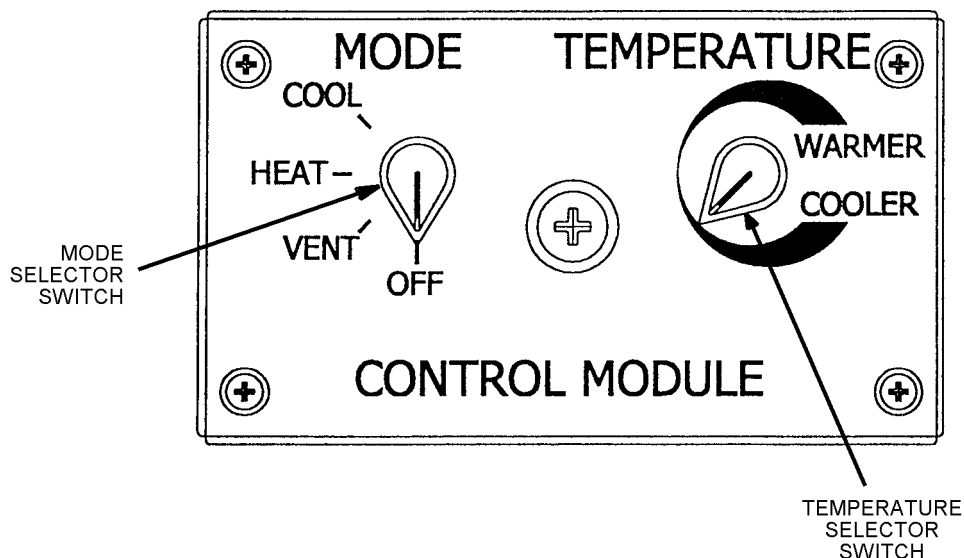

OPERATOR'S CONTROLS - Continued**4. Alternate Input Power Operation**

The air conditioner is shipped from the manufacturer wired for operation to use the main input power connector (J2) located in the front of the unit below the control module. When unit installation makes use of the primary input power receptacle inconvenient, an alternate input power receptacle is provided to allow power connections to the air conditioner. It is located in the rear of the unit. To use an alternate input power connection internal wiring connections must be made. The alternate input power connector is designated as (J1). Refer to Unit Maintenance and Schematic Diagram, WP 0122-00.

END OF TASK

INITIAL SETUP:**Maintenance Level**

Operator

References

WP 0011-00 (PMCS)

Equipment Condition

Mode selector switch in OFF position.

Correct voltage and phase power source (208 volts, three phase, 50/60hz) available.

Perform operator PMCS (WP 0011-00) as necessary.

General Installation Site Requirements

A relatively level surface.

An unobstructed flow of air from outside the area.

An unobstructed flow of air from inside the conditioned area.

An unobstructed flow of air from outside the conditioned area to the fresh air intake.

STARTING AND OPERATING INSTRUCTIONS FOR COOLING**Starting**

1. Perform the preventive maintenance checks and services before operation.
2. Check for correct voltage and phase at power source (208 volts, three phase, 50/60 hz).
3. Roll up and tie the canvas cover.
4. Ground the unit.
5. Connect the main power to the unit.

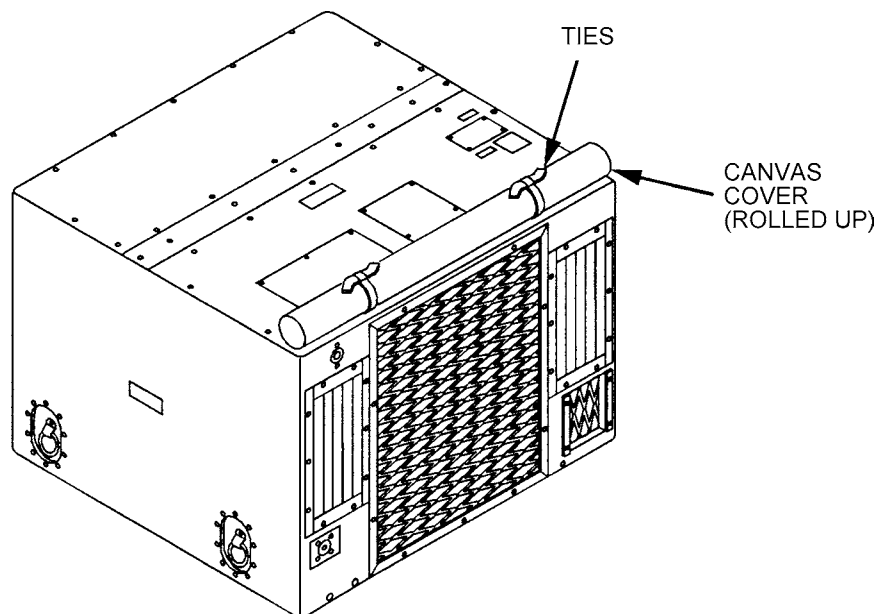

STARTING AND OPERATING INSTRUCTIONS FOR COOLING - Continued

Starting - Continued

6. Open the evaporator intake louvers by moving the tabs up or down as required. Ensure evaporator discharge louvers are open by adjusting each louver individually.

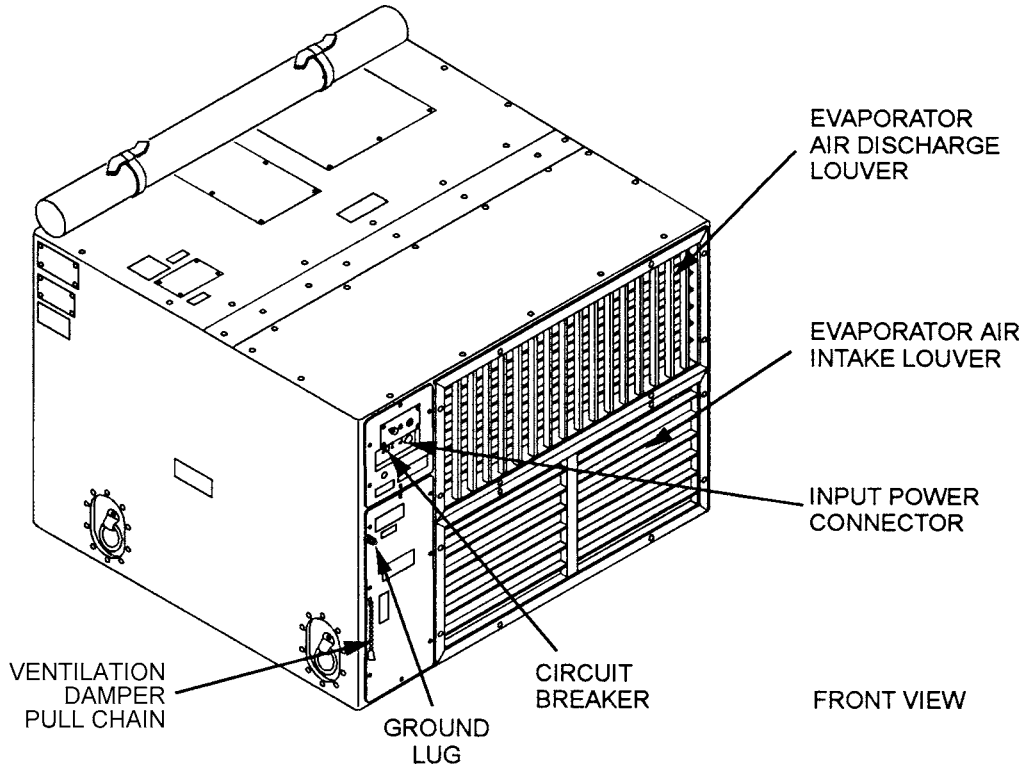

7. Adjust the ventilation damper to close the damper door (release pull chain).

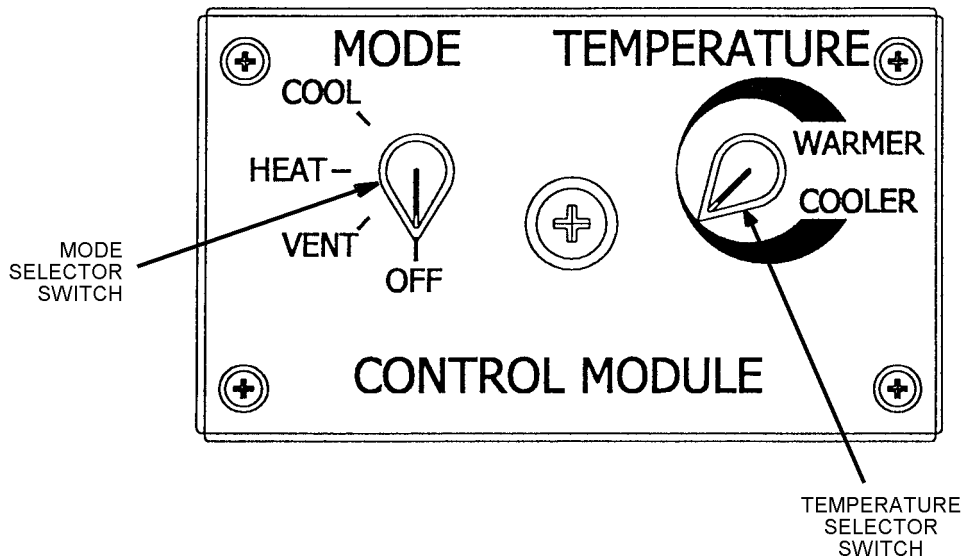

STARTING AND OPERATING INSTRUCTIONS FOR COOLING - Continued**Starting - Continued**

8. Turn the temperature selector switch to WARMER.
9. Position circuit breaker to "ON".
10. Position the mode selector switch to VENT, then position the mode selector switch to COOL.

Cooling Operation

WARNING

Do not operate the air conditioner in cool mode if the refrigerant is at a low level or if bubbles appear in sight glass. Equipment damage can result.

Compressor will begin operation. Allow 60 seconds delay for compressor to start.
After starting the air conditioner for cooling operation:

1. Leave the mode selector switch on COOL.
2. Adjust the temperature selector switch from WARMER to COOLER to select the degree of cooling desired. See Table 1 Operator Control Setting.
3. Adjust the evaporator discharge louvers individually to direct the airflow as desired.

NOTE

Cool air is denser than warm air so it has a tendency to flow downward. To offset this tendency, it is often advisable to adjust the evaporator discharge louvers to direct the cool air slightly upward.

NOTE

To open the ventilation damper door to admit fresh air, unlock the ventilation damper control chain, pull the door to an open position (against spring closure) and secure chain in slot.

Cooling With Fresh Air

1. When the ventilation damper door is open to admit fresh air, partially close the evaporator intake louver to balance the incoming air.
2. Keep the ventilation damper door closed during heavy rain.

Stopping The Air Conditioner

1. Position the mode selector switch to OFF.
2. Adjust the ventilation damper control chain to close the damper door.
3. If a shutdown is to be for an extended period, cover condenser side of unit with canvas cover and disconnect the power cable.

STARTING AND OPERATING INSTRUCTIONS FOR HEATING**Starting**

WARNING

For safe operation the air conditioner must be grounded prior to use.

1. Perform the preventive maintenance checks and services (WP 0011-00).
2. Check for the correct voltage and phase (208 volts, three-phase 50/60 Hz).
3. Roll up and tie canvas cover.
4. Ground the unit.
5. Open the evaporator intake louver by moving the blades up or down as required.
6. Open the evaporator discharge louvers.
7. Adjust the ventilation damper control chain to close the damper door.
8. Turn the temperature selector switch from COOLER to WARMER (lowest heating position - counter clockwise).
9. Position main circuit breaker to ON.
10. Position the mode selector switch to HEAT.

Heating Operation

After starting the air conditioner in the heating mode, adjust it as follows:

1. Adjust the temperature selector switch from COOLER to WARMER to select the desired temperature. See Table 1 Operator Control Settings. Heaters will cycle to maintain setting of temperature selector switch.
2. Adjust the evaporator discharge louver blades to direct the airflow as desired.

NOTE

Warm air is less dense than cool air, so it has a tendency to rise. To obtain comfortable temperatures near the floor and lower parts of the room, it is often advisable to adjust the evaporator discharge louver blades to direct the air slightly downward.

Heating Operation with Fresh Air

1. Open the damper door by adjusting the ventilation damper control chain if fresh air is desired.
2. Partially close the evaporator intake louver blades.

STARTING AND OPERATING INSTRUCTIONS FOR HEATING - Continued**Stopping The Air Conditioner**

1. Position the mode selector switch to OFF.
2. Adjust the ventilation damper control to close the damper door.
3. If a shutdown is to be for an extended period, cover condenser side of unit with canvas cover and disconnect the power cable.

Ventilating Operation

WARNING

For safe operation the air conditioner must be grounded prior to use.

To operate the air conditioner as a ventilating blower, without affecting temperature, proceed as follows:

1. Perform the preventive maintenance checks and services (WP 0011-00).
2. Check for the correct voltage and phase (208 volts, three-phase 50/60 Hz).
3. Roll up and tie the canvas cover.
4. Open the damper door by adjusting the ventilation damper control chain.
5. Partially close the evaporator intake louver blades.
6. Position the mode selector switch to VENT.
7. Open evaporator intake louvers.

Stopping The Air Conditioner

1. Position the mode selector switch to OFF.
2. Close the evaporator intake louver blades by pushing tabs down.
3. Adjust the ventilation damper control to close the damper door.
4. If a shutdown is to be for an extended period, cover condenser side of unit with canvas cover and disconnect the power cable.

Table 1. Operator Control Settings

Mode	Mode Selector Switch	Temperature Control Thermostat	Fresh Air Damper	Evaporator Inlet Louver	Evaporator Outlet Louver	Fabric Cover
Ventilate with 100% recirculated air	VENT	Does not operate	Closed	Open	Adjust to suit	Rolled up and secured
Ventilate with makeup (Fresh air)	VENT	Does not operate	Open	Partially closed	Adjust to suit	Rolled up and secured
Ventilate with 100% fresh air	VENT	Does not operate	Open	Closed	Adjust to suit	Rolled up and secured
Cooling with 100% recirculated air	COOL	Desired temperature	Closed	Open	Slightly up for best results	Rolled up and secured
Cooling with makeup (fresh air)	COOL	Desired temperature	Open	Partially closed	Slightly up for best results	Rolled up and secured
Heating with 100% recirculated air	HEAT	Desired temperature	Closed	Open	Slightly down for best results	Rolled up or snapped closed
Heating with makeup (fresh air)	HEAT	Desired temperature	Open	Partially closed	Slightly down for best results	Rolled up and secured

END OF TASK

INITIAL SETUP:

Maintenance Level

Operator

References

WP 0011-00 (PMCS)

Equipment Condition

Mode selector switch in OFF position.

Correct voltage and phase power source (208 volts, three-phase 50/60 Hz) available.

Perform operator PMCS (WP 0011-00) as necessary.

General Installation Site Requirements

A relatively level surface.

An unobstructed flow of air from outside the area.

An unobstructed flow of air from inside the conditioned area.

An unobstructed flow of air from outside the conditioned area to the fresh air intake.

NOTE

The air conditioner can be equipped for operation in chemical biological radiological (CBR) environment by connecting filtering equipment to the rectangular covered opening to the lower right of the fan guard in the rear of the unit.

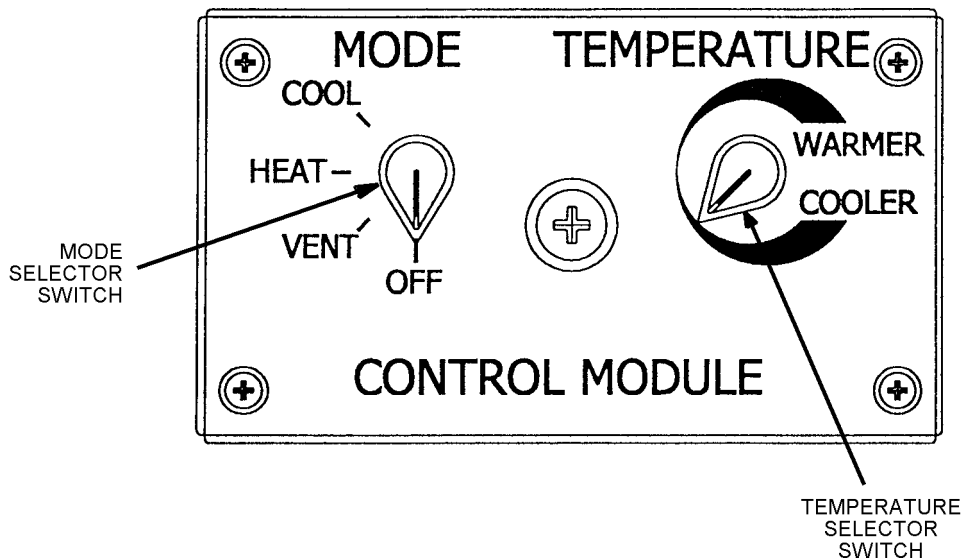

OPERATION IN EXTREME COLD**General**

The air conditioner is designed to operate on the heating cycle in ambient temperatures as low as -50°F (-45°C) and on cooling cycle with 35°F (1.6°C) air entering the condenser and 70°F (21°C) air entering the evaporator.

Before Operation

Before starting operation be sure canvas cover is rolled up and secured. Clear all ice and snow from openings. Be sure all dampers are in operating condition.

After Operation

Roll down and snap on canvas cover over condenser intake and outlet.

CAUTION

Do not disturb wiring during cold weather unless absolutely necessary. Cold temperatures make wiring and insulation brittle and easily broken.

OPERATION IN EXTREME HEAT**General**

The air conditioner is designed to operate satisfactorily at temperatures up to 120°F (49°C). If unit is operated at condenser inlet temperatures higher than 120°F (49°C), the cooling capacity will be lowered and long periods of operation at extended temperatures may cause compressor or condenser fan motor to overheat and trip their internal overload switches or the high pressure cutout switch to shut the unit off.

Filters

To maintain the highest capacity of the unit, the evaporator intake filter and fresh air screen should be cleaned weekly or more often if necessary. Dirty filters reduce the flow of air across the evaporator coil, thereby reducing the capacity of the air conditioner.

Guards and Louvers

Keep all guards and louvers clean and free of any obstructions to maintain full air flow through the air conditioner. Ensure the condenser louver in the rear of the unit is open.

Coils

Clean evaporator and condenser coils as frequently as necessary to prevent dirt or other matter from obstructing the air flow.

OPERATION IN DUSTY OR SANDY AREAS

1. Protection. Shield the air conditioner from dust as much as possible. Take advantage of any natural barriers which offer protection.
2. Cleaning. Keep the air conditioner as clean as possible. Pay particular attention to the louvers. Use compressed air, if available, to aid in cleaning.

NOTE

Never operate the unit without having the air filters in place.

OPERATION UNDER RAINY OR HUMID CONDITIONS

WARNING

Make sure power is disconnected from air conditioner before touching any wiring or other electrical parts.

Take special precautions to keep equipment dry. If installed outdoors, cover the equipment with a waterproof cover when it is not in use. Remove cover during dry periods. Take all necessary precautions to keep the electrical components free from moisture. Keep the fresh air vent damper door closed during heavy rain.

OPERATION IN SALT WATER AREAS

WARNING

Disconnect power source prior to washing the air conditioner.

1. General. Wash the exterior and the condenser section of the unit, with clean fresh water at frequent intervals. Be careful not to damage electrical system with water. Special attention must be given to prevent rust and corrosion.
2. Painting. Paint all exposed areas where paint has cracked, peeled, or blistered, or report condition to unit maintenance. Coat all exposed areas of polished metal with a light coat of grease.

END OF TASK

CHAPTER 3
OPERATOR TROUBLESHOOTING
PROCEDURES

MALFUNCTION/SYMPTOM INDEX

The malfunction/symptom index (WP 0009-00) is a quick reference index for finding troubleshooting procedures. Associated with each symptom name is a work package sequence number representing the starting point in a troubleshooting sequence. Should any one symptom require more than one troubleshooting sequence to arrive at the most likely area of investigation, the additional starting point numbers are presented.

As the troubleshooting activity progresses through to the conclusion of a particular sequence, a reference is made to the next logical troubleshooting sequence by work package sequence number or by referring to the malfunction/ symptom index to locate the next failure symptom work package. This type of activity continues until successful fault isolation is achieved.

TROUBLESHOOTING PROCEDURES

The troubleshooting work packages contain tables listing the malfunctions, tests or inspections, and corrective action required to return the air conditioner to normal operation. Perform the steps in the order they appear in the tables.

Each work package is headed by an initial setup. This setup outlines what is needed as well as certain conditions which must be met before starting the task. **DON'T START A TASK UNTIL:**

You understand the task.

You understand what you are to do.

You understand what is needed to do the work.

You have the things you need.

This manual cannot list all malfunctions that may occur, or all tests or inspections and corrective actions. If a malfunction is not listed or is not corrected by listed corrective actions, notify unit maintenance.

GENERAL INFORMATION**Circuit Breaker**

If the circuit breaker opens (trips) after it has been reset, notify unit maintenance.

Fan and Compressor Motor Lubrications

Motors driving the evaporator, condenser fans and compressor are permanently lubricated. The compressor is a sealed unit complete with lubricant. The rotating parts do not need any lubrication.

Condenser Air Discharge Louvers and Control Linkages, Fresh Air Damper Door

Notify unit maintenance of any stiffness or binding of operation.

GENERAL INFORMATION - Continued

Air Louvers

The evaporator louvers should operate freely using finger pressure. If they bind, lubricate with a small amount of lightweight general purpose machine oil. Refer to Item 14, WP 0121-00.

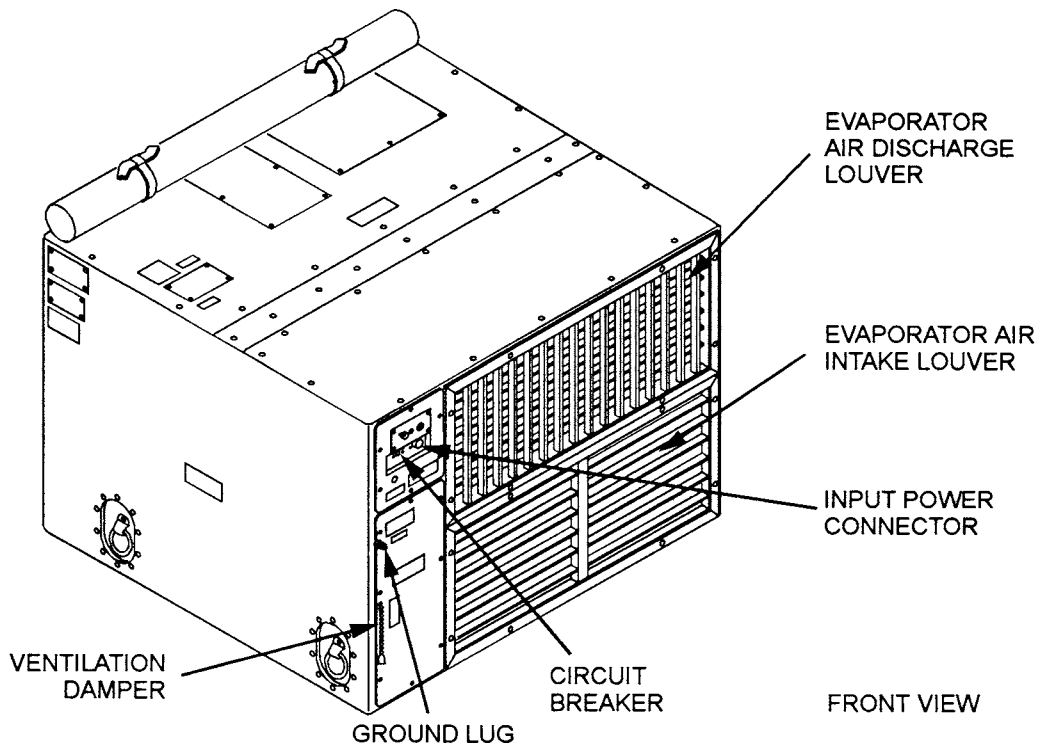

END OF TASK

MALFUNCTION/SYMPTOM	TROUBLESHOOTING PROCEDURE
Air Conditioner Fails to Operate	
1. Power cable not connected to proper voltage and phase or proper connector (J2 or J1 ALTERNATE).	WP 0010-00
2. Circuit breaker is OFF.	WP 0010-00
3. Mode selector switch is in OFF position.	WP 0010-00
4. High pressure switch has not been reset.	WP 0010-00
Insufficient Cooling	
1. Mode selector switch is not properly positioned on COOL.	WP 0010-00
2. Temperature switch is not set correctly to COOLER.	WP 0010-00
3. Insufficient air is passing across the evaporator coil due to intake and discharge louver obstructions.	WP 0010-00
4. Too much outside air is entering the unit through the damper door.	WP 0010-00
5. Insufficient refrigerant in the system.	WP 0010-00
6. Insufficient air is passing through the condenser coil due to inlet and outlet louver obstructions.	WP 0010-00
No Heat or Low Heat	
1. Temperature selector switch is not set correctly to WARMER setting.	WP 0010-00
2. Insufficient air is passing over heaters due to obstructions of evaporator air intake and discharge louvers.	WP 0010-00
3. Insufficient air is passing over heaters due to evaporator air intake louver blades being closed.	WP 0010-00

NOTE

Report fault to unit maintenance personnel if any of the following conditions occurs.

Compressor Will Not Start

- | | |
|--|------------|
| 1. High-or-low pressure cut-out switch may have an open contact. | WP 0014-00 |
| 2. Possible loose electrical connections or faulty wiring. | WP 0014-00 |

MALFUNCTION/SYMPTOM	TROUBLESHOOTING PROCEDURE
Compressor Will Not Start - Continued	
3. Control circuit may have an open circuit.	WP 0014-00
4. Transformer winding may be faulty.	WP 0014-00
5. Time delay device may be faulty.	WP 0014-00
6. Faulty compressor contactor contacts or coil.	WP 0014-00
7. Damage of mode selector switch.	WP 0014-00
Evaporator/Condenser Fan Motor Fails to Operate	
1. Faulty fan motor or bad start capacitor.	WP 0014-00
2. Evaporator/condenser fan or motor binding.	WP 0014-00
3. Poor continuity of wiring or terminals.	WP 0014-00
4. Bad fan motor relay contacts or coil.	WP 0014-00
5. Damage of mode selector rotary switch.	WP 0014-00
END OF TASK	

OPERATOR TROUBLESHOOTING PROCEDURES

0010-00

THIS WORK PACKAGE COVERS:

Air Conditioner Fails To Operate, Insufficient Cooling, No Heat or Low Heat

INITIAL SETUP:

Maintenance Level

Operator

Table 1. Troubleshooting Procedures

MALFUNCTION	TEST OR INSPECTION	CORRECTIVE ACTION
1. AIR CONDITIONER FAILS TO OPERATE	1. Verify that power cable is connected to proper voltage and phase with receptacle J2 or J1 ALTERNATE. 2. Verify that internal power connections are for power receptacle being used (J2 or J1 ALTERNATE). 3. Check to be sure that circuit breaker is ON. 4. Make sure that mode selector switch is not in OFF position. 5. Check that high pressure switch has been reset.	Connect power cable to receptacle. See WP 0122-00 schematic diagram. See WP 0122-00 Schematic Diagram for proper power connection for power receptacle being used. Reset circuit breaker. Turn selector knob to desired operation. Reset pressure switch and wait for compressor to start.
2. INSUFFICIENT COOLING	1. Check to be sure that mode selector switch is properly positioned. 2. Make sure that temperature switch is set correctly. 3. Determine that sufficient air is passing across evaporator coil by placing a piece of paper in front of the evaporator air intake louver. The paper should be held against the louver blades by the air. 4. Make sure that there is not too much outside air entering unit. 5. Check liquid sight indicator to see whether there is sufficient refrigerant in the system.	Set switch to COOL. Adjust setting to COOLER. Open evaporator air intake louver blades. Remove any obstructions from evaporator air intake and discharge louvers. Direct discharge air louvers away from intake air. Refer to WP 0012-00. Close or adjust fresh air damper door. If sight glass is not full and clean report to Direct Support Maintenance Personnel.

Table 1. Troubleshooting Procedures - Continued

MALFUNCTION	TEST OR INSPECTION	CORRECTIVE ACTION
2. INSUFFICIENT COOLING- Continued	6. Check to see that sufficient air is passing through condenser coil by placing a piece of paper on the condenser guard. The paper should be held against the guard by the air.	Remove any obstructions from condenser inlet and outlet. Make sure that condenser louver outlets are open. Refer to WP 0012-00.
3. NO HEAT OR LOW HEAT	1. Check to be sure that mode selector switch is properly positioned. 2. Make sure that temperature selector switch is set correctly. 3. Check for sufficient air movement over heaters by placing a piece of paper in front of the evaporator air intake louver. The paper should be held against the louver by the air. 4. Make sure that there is not too much outside air entering unit.	Set switch to HEAT. Adjust setting to warmer. Remove any obstructions from evaporator air intake and discharge louvers. Make sure that evaporator air intake louver blades are open. Direct discharge air louvers away from intake air. Refer to WP 0012-00. Close or adjust fresh air damper door.

END OF TASK

CHAPTER 4

**OPERATOR
MAINTENANCE INSTRUCTIONS**

OPERATOR PREVENTIVE MAINTENANCE CHECKS AND SERVICES

0011-00

THIS WORK PACKAGE COVERS:Introduction, PCMS Procedures

INITIAL SETUP:**Maintenance Level**Operator

INTRODUCTION**General**

Preventive Maintenance Checks and Services (PMCS) are performed to keep the air conditioner in operating condition. The checks are used to find, correct, or report problems. Operator is to do the PMCS jobs as shown in the PMCS table. PMCS are done before and after the air conditioner is operated, using the PMCS table. Pay attention to WARNING and CAUTION statements. A WARNING means someone could be hurt. A CAUTION means equipment could be damaged.

Before you operate, do Before PMCS.

During operation, do During PMCS.

After operation, do After PMCS.

If you find something wrong when performing PMCS, fix it if you can, using troubleshooting procedures and/or maintenance procedures.

The right-hand column of the PMCS table lists conditions that make the air conditioner not fully mission capable. Write up items not fixed on DA Form 2404 for unit maintenance. For further information on how to use this form, see DA PAM 738-750.

If tools required to perform PMCS are not listed in WP 0118-00, notify unit maintenance.

NOTE

If the equipment must be kept in continuous operation, check and service only those items that can be checked and serviced without disturbing operation. Make the complete checks and services when the equipment can be shut down.

Table 1. Operator Preventive Maintenance Checks and Services (PMCS)

NOTE

Within designated intervals, these checks are to be performed in the order listed.

ITEM NO.	INTERVAL	ITEM TO BE CHECKED OR SERVICED	PROCEDURE	EQUIPMENT NOT READY/AVAILABLE IF:
1	Before	Ground Stud	Ensure unit is grounded with stud near control module.	Unit not grounded.
2	Before	Panels and Covers	Inspect for security of attachment and cleanliness. Report damaged condition to Unit Maintenance personnel.	Panels or covers missing or severely damaged.
3	Before	Fresh Air Filter	Inspect for cleanliness, obstructions and insecure mountings. Remove obstructions.	Filter obstructed, damaged, loose, missing or requires cleaning.
4	Before	Condenser Coil Guard	Inspect for cleanliness, obstructions, damage, and security of attachment. Report damaged condition to Unit Maintenance personnel.	Guard requires cleaning, is obstructed, damaged, loose or missing.
5	Before	Evaporator Air Discharge Louver	Inspect for cleanliness, obstructions, damage, and security of attachment. Report damaged condition to Unit Maintenance personnel.	Louver requires cleaning, is obstructed, damaged, loose or missing.
6	Before	Evaporator Air Intake Louver	Inspect for cleanliness, obstructions, damage, and security of attachment. Report damaged condition to Unit Maintenance personnel.	Louver requires cleaning, is obstructed, damaged, loose or missing.
7	Before	Condenser Louvers	Check for insecure mountings and damaged louver blades. Report damaged condition to Unit Maintenance personnel.	Louvers require cleaning, are obstructed, damaged or loose.
8	Before	Information Plates	Check for security and legibility.	
9	Before	Condensate Drain Tubes	Inspect drains for obstructions. Remove obstructions as required.	Obstructions cannot be removed.
10	Before	Control Module	Ensure knobs are in place and check to see that switches function properly. Report damaged condition to Unit Maintenance personnel.	Knobs are missing or switches do not function properly.

Table 1. Operator Preventive Maintenance Checks and Services (PMCS) - Continued

ITEM NO.	INTERVAL	ITEM TO BE CHECKED OR SERVICED	PROCEDURE	EQUIPMENT NOT READY/AVAILABLE IF:
11	During	Liquid Sight Indicator	After approximately 5 minutes in "COOL" mode operation, check for moisture and low refrigerant charge. Yellow indicates moisture; bubbles or milky appearance indicates low charge. Report abnormal condition to Direct Support Maintenance personnel.	Moisture or low charge is indicated.

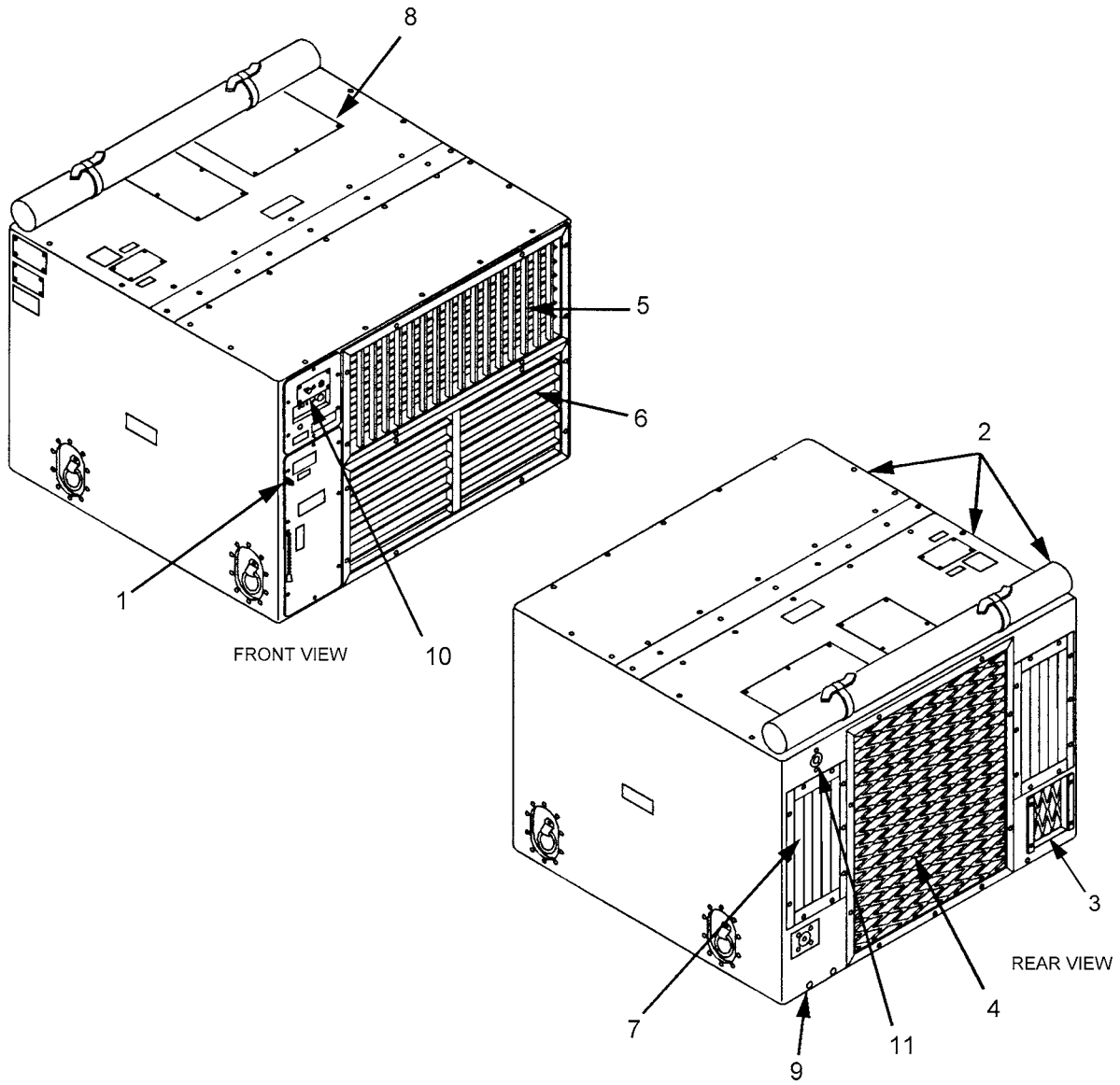

Table 1. Operator Preventive Maintenance Checks and Services (PMCS) - Continued

ITEM NO.	INTERVAL	ITEM TO BE CHECKED OR SERVICED	PROCEDURE	EQUIPMENT NOT READY/AVAILABLE IF:
12	After	Panels and Covers	Inspect for security of attachment and cleanliness. Report damaged condition to Unit Maintenance personnel.	Panels and covers missing or severely damaged.
13	After	Fresh Air Filter	Inspect for obstructions and insecure mountings. Remove obstructions.	Filter missing, loose or damaged.
14	After	Condenser Coil Guard	Inspect for cleanliness, obstructions, damage, and security of attachment. Report damaged condition to Unit Maintenance personnel.	Guard requires cleaning, is obstructed, damaged, loose or missing.
15	After	Evaporator Air Discharge Louver	Inspect for cleanliness, obstructions, damage, and security of attachment. Report damaged condition to Unit Maintenance personnel.	Louver requires cleaning, is obstructed, damaged, loose or missing.
16	After	Evaporator Air Intake Louver	Inspect for cleanliness, obstructions, damage, and security of attachment. Report damaged condition to Unit Maintenance personnel.	Louver requires cleaning, is obstructed, damaged, loose or missing.
17	After	Condenser Louvers	Check for insecure mountings and damaged louver blades. Report damaged condition to Unit Maintenance personnel.	Louvers require cleaning, are obstructed, damaged or loose.
18	After	Information Plates	Check for security and legibility.	
19	After	Condensate Drain Tubes	Inspect drains for obstructions. Remove obstructions as required.	Obstructions cannot be removed.

END OF TASK

OPERATOR MAINTENANCE INSTRUCTIONS

0012-00

THIS WORK PACKAGE COVERS:

Service and Cleaning of Screens and Guards,
Adjusting Louvers, Damper and Control Module

INITIAL SETUP:**Maintenance Level**

Operator

Materials/Parts

Dry Cleaning Solvent
(Item 16, WP 0121-00)
Brush
Cleaning Cloth (Item 9, WP 0121-00)

WARNING

Disconnect the power source before performing any maintenance function.

WARNING

Do not use compressed air for cleaning purposes except where reduced to less than 30 psi (2.1 kg/cm²) and then only with effective chip guarding and personnel protective equipment.

WARNING

Dry cleaning solvent (WP 0121-00) used to clean parts is potentially dangerous to personnel and property. Avoid repeated and prolonged skin contact. Do not use near open flame or excessive heat. Flash point of solvent is 100°F (38°C).

SERVICE AND CLEANING**Screens and Guards**

1. Brush off any loose dirt or foreign matter, and remove obstructions from the condenser guard & fresh air screen.
2. Wipe off with a cloth moistened with dry cleaning solvent (WP 0121-00).
3. Inspect for security of attachment and damage.
4. Report damaged condition to unit maintenance personnel.

SERVICE AND CLEANING - Continued

Screens and Guards - Continued

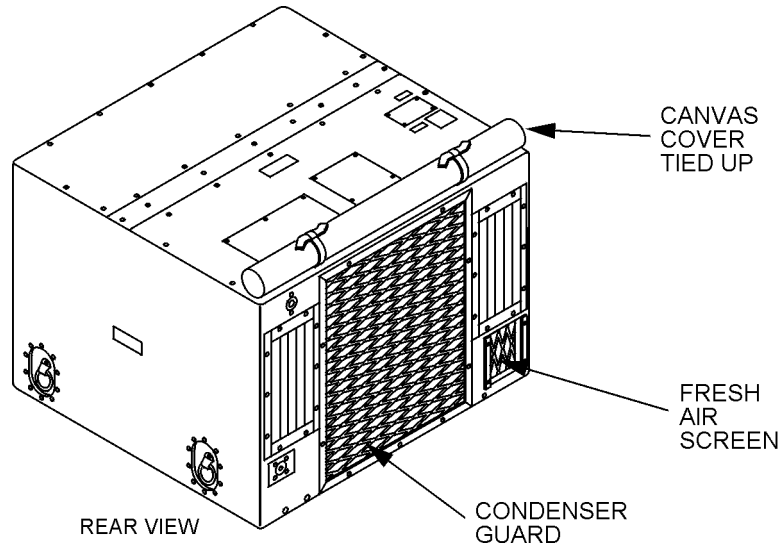

ADJUST

Evaporator Louvers

1. Position the evaporator air intake louver so that the louvers are fully open when the ventilation damper door is in the closed position. Partially close the evaporator inlet louver when the ventilation damper door is in the open position.
2. It is recommended that the evaporator air discharge louver be adjusted to direct the airflow slightly upward when the air conditioner is operated in the cool mode, and slightly downward when the air conditioner is operated in the heat mode.

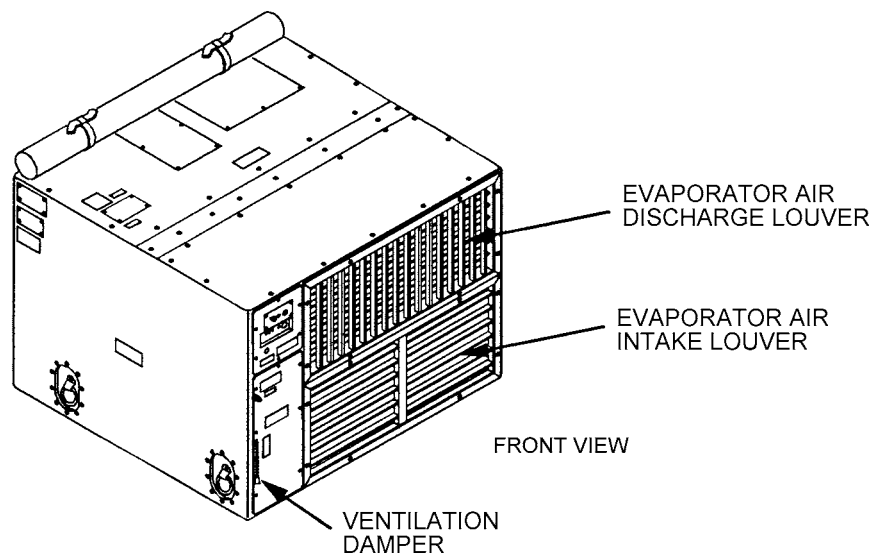

ADJUST - Continued**Ventilation Damper Control**

1. Check for binding; remove obstructions.
2. Brush off any loose dirt or foreign matter.
3. Inspect for security of attachment and damage.
4. Report damaged condition to unit maintenance personnel.
5. Adjust ventilation damper control to desired degree of fresh air.

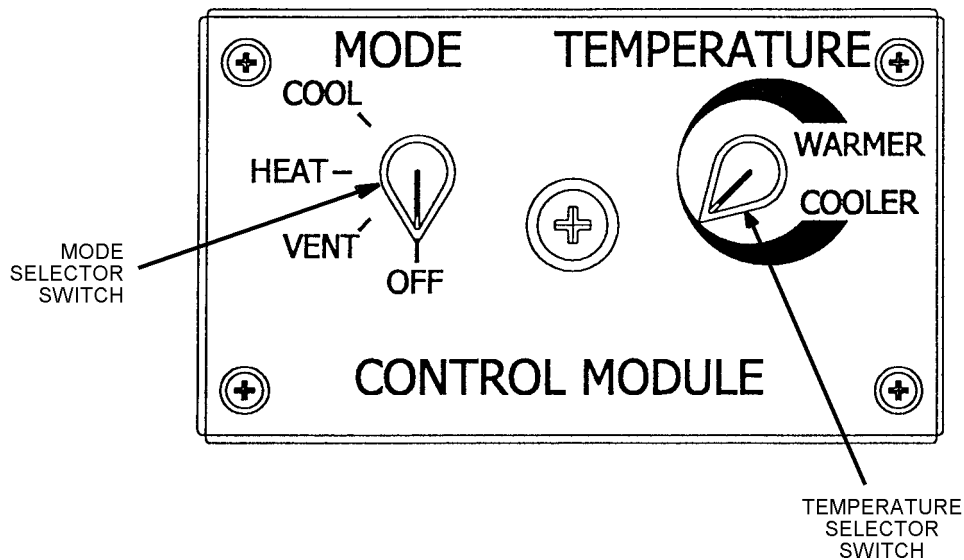
Control Module

1. Rotate the temperature selector switch to cooler (counter-clockwise) or warmer (clockwise) while the air conditioner is being operated in either the cool or heat mode in order to achieve the desired temperature in the conditioned area.
2. Rotate the mode selector switch to the vent, heat or cool position (clockwise), or to the heat position (counter-clockwise).

END OF TASK

CHAPTER 5
UNIT
TROUBLESHOOTING

MALFUNCTION/SYMPTOM INDEX

The malfunction/symptom index (WP 0009-00) is a quick reference index for finding troubleshooting procedures. Associated with each symptom name is a work package sequence number representing the starting point in a troubleshooting sequence. Should any one symptom require more than one troubleshooting sequence to arrive at the most likely area of investigation, the additional starting point numbers are presented.

As the troubleshooting activity progresses through to the conclusion of a particular sequence, a reference is made to the next logical troubleshooting sequence by work package sequence number or by referring to the malfunction/ symptom index to locate the next failure symptom work package. This type of activity continues until successful fault isolation is achieved.

TROUBLESHOOTING PROCEDURES

The troubleshooting work packages contain tables listing the malfunctions, tests or inspections, and corrective action required to return the air conditioner to normal operation. Perform the steps in the order they appear in the tables.

Each work package is headed by an initial setup. This setup outlines what is needed as well as certain conditions which must be met before starting the task. **DON'T START A TASK UNTIL:**

Check the power source voltage and phase.

You understand the task.

You understand what you are to do.

You understand what is needed to do the work.

You have the things you need.

This manual cannot list all malfunctions that may occur, or all tests or inspections and corrective actions. If a malfunction is not listed or is not corrected by listed corrective actions, notify unit maintenance.

GENERAL INFORMATION**Fan and Compressor Motor Lubricants**

Motors driving the evaporator/condenser fan and compressor are permanently lubricated. The compressor is a sealed unit complete with lubricant. The rotating parts do not need any lubrication.

Mechanical Lubrication

The only mechanical items which may require lubrication are the conditioned air supply and return louvers, the condenser air discharge louver and control linkages. These points should be checked and lubricated, as necessary, during preventive maintenance service. A few drops of light oil should be applied to pivot points, bearing surfaces, and linkages to prevent or eliminate stiffness or binding. Be sure to wipe off all excess oil with a cloth or paper towel. These items are in an area of high volume air flow and excess oil will tend to attract and accumulate dust particles from the passing air. Graphite may be used as an alternate lubricant during extreme cold weather operation.

END OF TASK

UNIT TROUBLESHOOTING**0014-00**

THIS WORK PACKAGE COVERS:

Air Conditioner Fails To Operate, Insufficient Cooling, Fan Motor Fails To Operate, Compressor Will Not Start, Insufficient Heating

INITIAL SETUP:**Maintenance Level**

Unit

Reference

WP 0009-00, Malfunction/Symptom Index

General

This section provides information useful in diagnosing and correcting unsatisfactory operation or failure of the air conditioner. Each malfunction is followed by a list of probable causes and actions to take to remedy the malfunction. You should perform the tests/inspections and corrective actions in the order listed. Refer to the malfunction/symptom index (WP 0009-00) as a quick reference index for troubleshooting procedures.

This manual cannot list all malfunctions that may occur nor all tests or inspections and corrective actions. If a malfunction is not listed or is not corrected by listed corrective actions, notify your supervisor.

Control Circuit

The cause of a system's failure to operate can be greatly narrowed if the control that caused the failure can be isolated. It is the function of safety devices to open the circuit under certain conditions; therefore, additional checking may be required to determine whether the safety device is open because it is bad or because it is doing what it is supposed to do. The following steps contain instructions for checking the control circuit.

1. Disconnect power from the air conditioner and position Mode Selector rotary switch to "OFF".
2. Test continuity across each control in the affected circuit, using an ohmmeter. Refer to the appropriate schematic diagram (WP 0122-00) as a guide to the connections in the circuit.
3. Replace defective parts.

Safety Devices

When testing the control circuit and other equipment, you must take into consideration the fact that open safety devices may not be bad. It may be normal for the device to be open under the existing conditions, or it may indicate trouble elsewhere in the air conditioner.

WARNING

Refrigerant under pressure is used in the operation of this equipment.

WARNING

HIGH VOLTAGE is used in the operation of this equipment. DEATH ON CONTACT may result if personnel fail to observe safety precautions. Never work on electrical equipment unless there is another person nearby who is familiar with the operation and hazards of the equipment and who is competent in administering first aid. When the technician is aided by operators, he must warn them about dangerous areas.

WARNING

Always ensure the input power supply to the equipment is shut off before beginning work on the equipment.

Be careful not to contact high voltage connections of 208 volts AC circuits when servicing this equipment. Whenever the nature of the operation permits, keep one hand away from the equipment to reduce the hazard of current flowing through vital organs of the body.

Do not be misled by the term "low voltage." Potentials as low as 30 volts may cause death under adverse conditions.

WARNING

Take particular care to ground capacitor C1 which is likely to hold a dangerous potential. When working inside the equipment, after the power has been turned off, always ground every part before touching it.

WARNING

Do not operate the equipment without all guards, louvers, and covers, including compressor terminal cover, in place and tightly secured.

WARNING

The refrigerant system and components contain liquid and gas under high pressure.

Table 1. Unit Troubleshooting Procedures

MALFUNCTION	TEST OR INSPECT	CORRECTIVE ACTION
<p>NOTE Before using this table, be sure you have performed all applicable operating checks.</p>		
<p>1. AIR CONDITIONER FAILS TO OPERATE</p>	<ol style="list-style-type: none"> 1. Check to see that main power cable is connected to air conditioner and power source. 2. Make sure that you are using the correct voltage and phase. 3. Inspect main power receptacle connections for breaks. 4. Check for loose electrical connections. 5. Inspect rotary selector switch for incorrect setting. (See Table Of Operator Control Settings.) 6. Check to see whether CIRCUIT BREAKER is in the OFF position or is defective. 7. Disconnect control circuit transformer and make continuity check of primary and secondary windings, and from windings-to-case, using ohmmeter 	<p>Connect cable.</p> <p>Check line voltage with multimeter for 208 V ac, three-phase, 50/60 Hz power.</p> <p>Replace connector. (Refer to WP 0043-00.)</p> <p>Tighten connections.</p> <p>Turn selector switch to COOL or VENTILATE.</p> <ol style="list-style-type: none"> 1. Reset circuit breaker 2. Make continuity check with multimeter. Refer to WP 0033-00. <p>If windings do not show continuity or if windings-to-case continuity exists, replace transformer. (Refer to WP 0035-00.)</p>
<p>2. INSUFFICIENT COOLING</p>	<ol style="list-style-type: none"> 1. Check to see that Mode Selector switch is properly positioned. 2. Check liquid sight indicator level to see that refrigerant is colorless and clear. Yellow indicates moisture in system. Milky or bubbly refrigerant indicates low level refrigerant charge. 3. Inspect condenser coil for dirt. 4. Inspect evaporator air intake filter for dirt. 	<p>Turn selector switch to COOL.</p> <p>Report condition to Direct Support Maintenance personnel.</p> <p>Clean coil with 25-30 psi (1.76-2.11 kg/cm²) compressed air.</p> <p>Clean filter.</p>

Table 1. Unit Troubleshooting Procedures - Continued

MALFUNCTION	TEST OR INSPECT	CORRECTIVE ACTION
<p>2. INSUFFICIENT COOLING - Continued</p>	<p>5. See whether Temperature Selector switch is set incorrectly or is defective.</p> <p>6. Test evaporator air discharge louver to see whether it is bent, or stuck in the CLOSED position.</p> <p>7. Observe evaporator fan motor or condenser fan motors to see whether they are defective.</p> <p>8. Check to see whether evaporator impeller fan or condenser fans are loose or defective.</p> <p>9. Check high pressure cutout switch.</p>	<p>Adjust setting or replace switch or other corrective action. (Refer to WP 0034-00.)</p> <p>Repair or replace louver. (Refer to WP 0020-00.)</p> <p>Report fault to Direct Support Maintenance personnel or replace motor. (Refer to WP 0030-00 and WP 0031-00.)</p> <p>Tighten setscrew or replace fan. (Refer to WP 0030-00 and WP 0031-00.)</p> <p>Reset.</p>
<p>3. EVAPORATOR OR CONDENSER FAN MOTOR FAILS TO OPERATE</p>	<p>1. Make sure that power cable is properly connected.</p> <p>2. Test for bad fan motor. (Refer to WP 0030-00 and WP 0031-00.) Check for bad capacitor by using a multimeter.</p> <p>3. Check evaporator or condenser fan motor for binding.</p> <p>4. Check continuity of wiring connections. (Refer to WP 0030-00 and WP 0031-00.)</p> <p>5. Disconnect fan motor relay. Actuate primary contacts with 24 volt AC source, then check continuity of contacts that should be closed. (Refer to WP 0036-00.)</p> <p>6. Inspect Mode Selector rotary switch for failure or damage. (Refer to WP 0034-00.)</p>	<p>Connect cable.</p> <p>Report fault to Direct Support Personnel. (Refer to WP 0030-00 and WP 0031-00.)</p> <p>Report fault to Direct Support Personnel. (Refer to WP 0030-00 and WP 0031-00.)</p> <p>Replace or repair wiring connections. (Refer to WP 0122-00.)</p> <p>Replace bad relay. (Refer to WP 0036-00.)</p> <p>Replace bad switch. (Refer to WP 0034-00.)</p>

Table 1. Unit Troubleshooting Procedures - Continued

MALFUNCTION	TEST OR INSPECT	CORRECTIVE ACTION
<p>WARNING</p>		
<p>Disconnect the power source.</p>		
<p>4. COMPRESSOR WILL NOT START</p>	<ol style="list-style-type: none"> 1. Make sure that circuit breaker or selector switch is properly set. 2. Check for open contacts of high-or-low-pressure cut-out switches. (Refer to WP 0072-00.) 3. Check for loose electrical connections. 4. Make continuity check of control circuit to determine whether open circuit exists. (Refer to WP 0034-00.) 5. Check continuity across primary winding and across secondary winding of control transformer to see whether windings are good. (Refer to WP 0035-00.) 6. Observe operation of time delay device and check continuity. (Refer to WP 0035-00.) 7. Check that the Mode Selector switch is in the COOL position. 	<p>Reset controls properly.</p> <ol style="list-style-type: none"> 1. Reset high pressure switch. 2. Report fault to Direct Support Maintenance personnel if condition continues. <ol style="list-style-type: none"> 1. Tighten loose connections. 2. If wiring replacement is necessary notify direct support. <p>Repair open circuit or replace wire. (Refer to WP 0034-00.)</p> <p>Replace bad transformer. (Refer to WP 0035-00.)</p> <p>Replace bad time delay device. (Refer to WP 0035-00.)</p> <ol style="list-style-type: none"> 1. Switch to COOL position. 2. Replace bad Mode Selector switch. (Refer to WP 0034-00.)
<p>5. INSUFFICIENT HEATING</p>	<ol style="list-style-type: none"> 1. Check that Mode Selector switch is in HEAT position. 	<ol style="list-style-type: none"> 1. Switch to HEAT position. 2. Replace bad Mode Selector switch. (Refer to WP 0034-00.)

Table 1. Unit Troubleshooting Procedures - Continued

MALFUNCTION	TEST OR INSPECT	CORRECTIVE ACTION
5. INSUFFICIENT HEATING - Continued	2. Check that the MAIN CIRCUIT BREAKER is in the ON position 3. Check that Temperature Selector switch is in WARMER position.	1. Switch to ON position. 2. Replace bad MAIN CIRCUIT BREAKER. (Refer to WP 0033-00.) 1. Switch to WARMER position. 2. Replace bad Temperature Control. (Refer to WP 0034-00.)

END OF TASK

CHAPTER 6
UNIT
MAINTENANCE INSTRUCTIONS

**UNIT MAINTENANCE
SERVICE UPON RECEIPT**

0015-00

THIS WORK PACKAGE COVERS:

Unloading, Unpacking, Checking Unpacked Equipment, Installation, Connect to Power Source, Operation Check and Adjustment

INITIAL SETUP:

Maintenance Level

Unit

Tools and Special Tools

Tool Kit, General Mechanics (Item 1, Table 2, WP 0118-00)

References

WP 0001-00

WP 0119-00

Equipment Condition

Main power source is disconnected.

UNLOADING

The air conditioner is packaged in a container designed for shipment and handling with the unit in an upright position. The base of the container is constructed as a shipping pallet with provisions for the insertion of the tongs of a forklift. The unit may be lifted by forklift, crane, or sling. To unload the air conditioner, perform the following steps.

1. Remove all blocking and tie downs that may have been used to secure the container to the carrier

WARNING

Do not allow the unit to swing while suspended from a lifting device. Failure to observe this warning may result in injury to personnel and damage to the equipment.

CAUTION

Use care when handling to avoid damage to the air conditioner. If an overhead lifting device must be used, use an appropriate sling so that the weight of the unit is supported by the base of the shipping container.

2. Use a forklift truck or other suitable material handling equipment to remove the unit from the carrier.

UNPACKING

CAUTION

To protect the air conditioner and prevent damage, the air conditioner should be left packaged until it is moved to the location where it is to be installed.

UNPACKING - Continued**NOTE**

The shipping container is of such design that it may be retained for re-use for mobility purposes if frequent relocation of the air conditioner is anticipated.

1. Remove shipping container.
2. Cut the metal bands that hold the top of the container to the base.
3. Remove staples that secure fiberboard container to pallet.
4. Remove the cushioning around the top of the cabinet and retain if re-use is anticipated.
5. Remove the preservation barrier by tearing around the bottom of the cabinet.
6. Remove the technical publications envelope and accessory sack and put them in a safe place.

NOTE

It is recommended that the cabinet be left bolted to the shipping pallet until time to place it in the installation position. All receiving inspection actions can be conducted without removal from the pallet.

7. Remove pallet.

WARNING

Do not allow the unit to swing while suspended from a lifting device. Failure to observe this warning may result in injury to personnel and damage to the equipment.

CAUTION

Use care in handling to avoid damage to the air conditioner. If an overhead lifting device must be used, use an appropriate sling so that the weight of the unit is supported by the base of the shipping container.

8. Attach an overhead hoist with an appropriate sling and spreader bar to the lifting fittings provided at each side of the cabinet then raise the cabinet and remove the bolts that hold the air conditioner to the pallet.
9. Remove and retain the pallet and bolts if re-use is anticipated. Be sure to remove all remaining barrier material from the underside of the cabinet base.
10. Lower the cabinet to the floor in the desired position and remove the sling and hoist.

**UNIT MAINTENANCE
SERVICE UPON RECEIPT - Continued**

0015-00

Table 1. Service Upon Receipt Checklist

Location	Item	Action	Reference
1. Exterior	Louvers, Covers, Drains Guards, Controls, Switches	Perform operator PMCS before you operate.	WP 0011-00
2. Front	Main Power Connectors	a. Inspect connector for damage. b. Replace damaged connector.	WP 0011-00 WP 0043-00

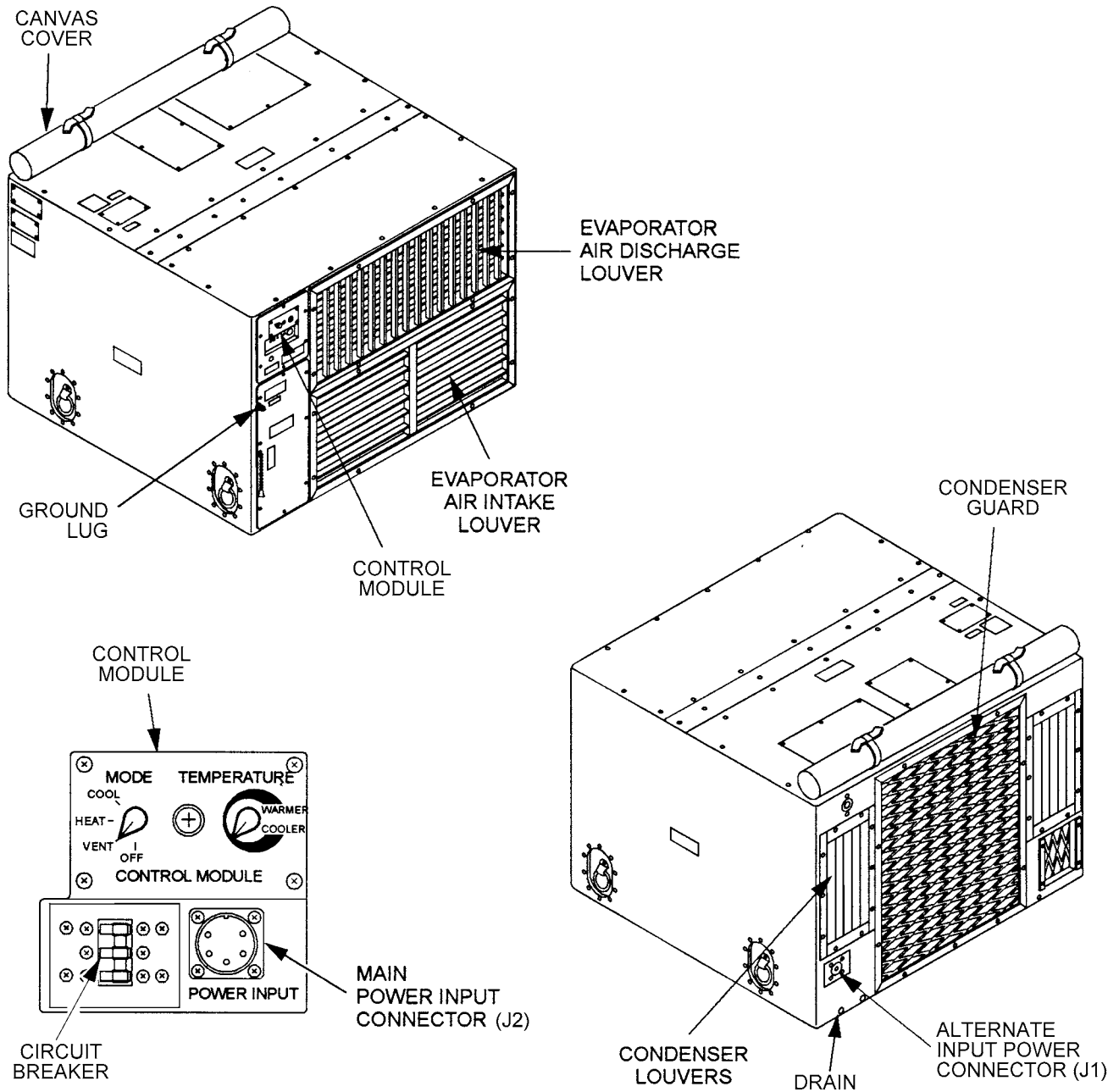

CHECKING UNPACKED EQUIPMENT

1. Inspect the equipment for damage incurred during shipment. If the equipment has been damaged, report the damage on DA Form 368 Quality Deficiency Report (QDR).
2. Check the equipment against the packing slip to see if the shipment is correct and complete. Report all discrepancies in accordance with the instructions of DA PAM 738-750.
3. Check to see whether the equipment has been modified.

INSTALLATION

General

1. Air conditioner is assembled and ready for operation.
2. It contains full charge of refrigerant and compressor oil.

Mounting

1. Place the unit on a firm, level surface to permit proper drainage of water that condenses out of the air or rain.
2. Position the unit so that the control panel, the condenser, and the evaporator louvers are accessible to the operator and to maintenance personnel.
3. Check that there are no obstructions in front of any air intake or discharge louvers or other openings.
4. The dimensions for base-mounting holes on the enclosure mount (6) are shown on the dimension and hardware location illustration. The resilient mount (3), washer (2), spacer (4), elastomeric tube (5) and cap screw (1) are shipped with the air conditioner.
5. Connect a drain line if necessary.

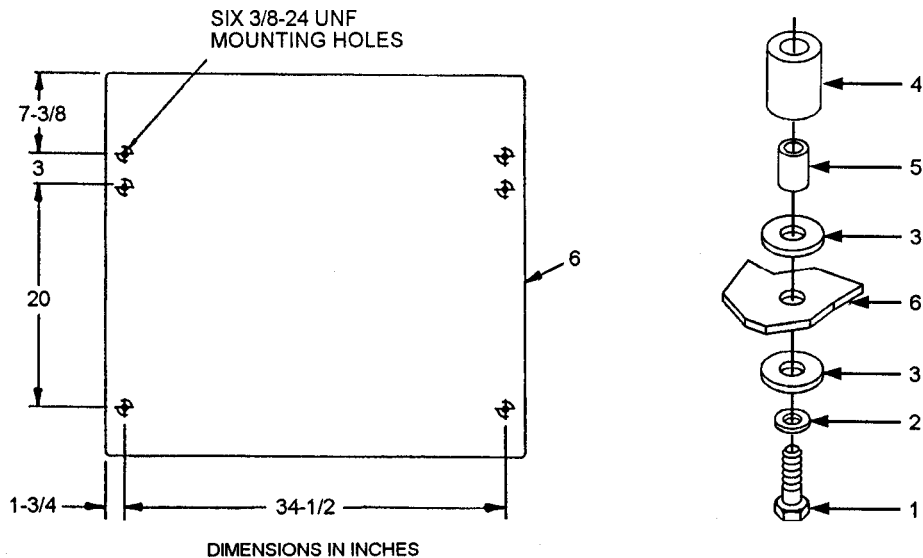

**UNIT MAINTENANCE
SERVICE UPON RECEIPT - Continued**

0015-00

INSTALLATION - Continued**Grounding**

1. Clean front of ground connection to obtain a bright metal surface.
2. Remove insulation from ends of grounding wire (10 AWG) or use bare ends. Make loop at wire ends.
3. Using 1/4-20 nut and washer, attach one end of wire to air conditioner front panel ground stud.
4. Wrap a suitable length of perforated strap around clean surface on water pipe or grounding rod.
5. Using a 1/4-20 screw, two washers and nut, attach other end of grounding wire to strap in a manner such as to securely tighten strap to pipe or grounding rod, (10 AWG) and wire to strap. If vehicle chassis is used, secure other end of grounding wire to vehicle chassis using screw, nut, and lockwasher. The screw shall fit in a tapped hole in the chassis or frame or it shall be held in hole by nut.

WARNING

The vehicle chassis (if used) must be grounded before power is supplied to the unit.

CONNECT POWER SOURCE

CAUTION

Make sure the mode selector switch and circuit breaker are in the OFF position.

CAUTION

For safe operation, be sure a ground wire (at least No. 10 AWG) is connected to the unit ground connection and a ground source.

1. Connect a compatible air conditioner power cable to a 208-volt, 50/60 Hz, three phase power source.
2. If auxiliary power input connector (J1) is used, refer to Schematic Diagram WP 0122-00 and WP 0119-00, Table 1.

OPERATION CHECK AND ADJUSTMENTS

1. Check operation of unit.
2. Check for proper power wiring sequence (ABC) which effects compressor direction of rotation. Incorrect wiring results in noisy compressor operation with little or no cooling. Prolonged operation in reverse direction will damage compressor.

UNIT MAINTENANCE
SERVICE UPON RECEIPT - Continued

0015-00

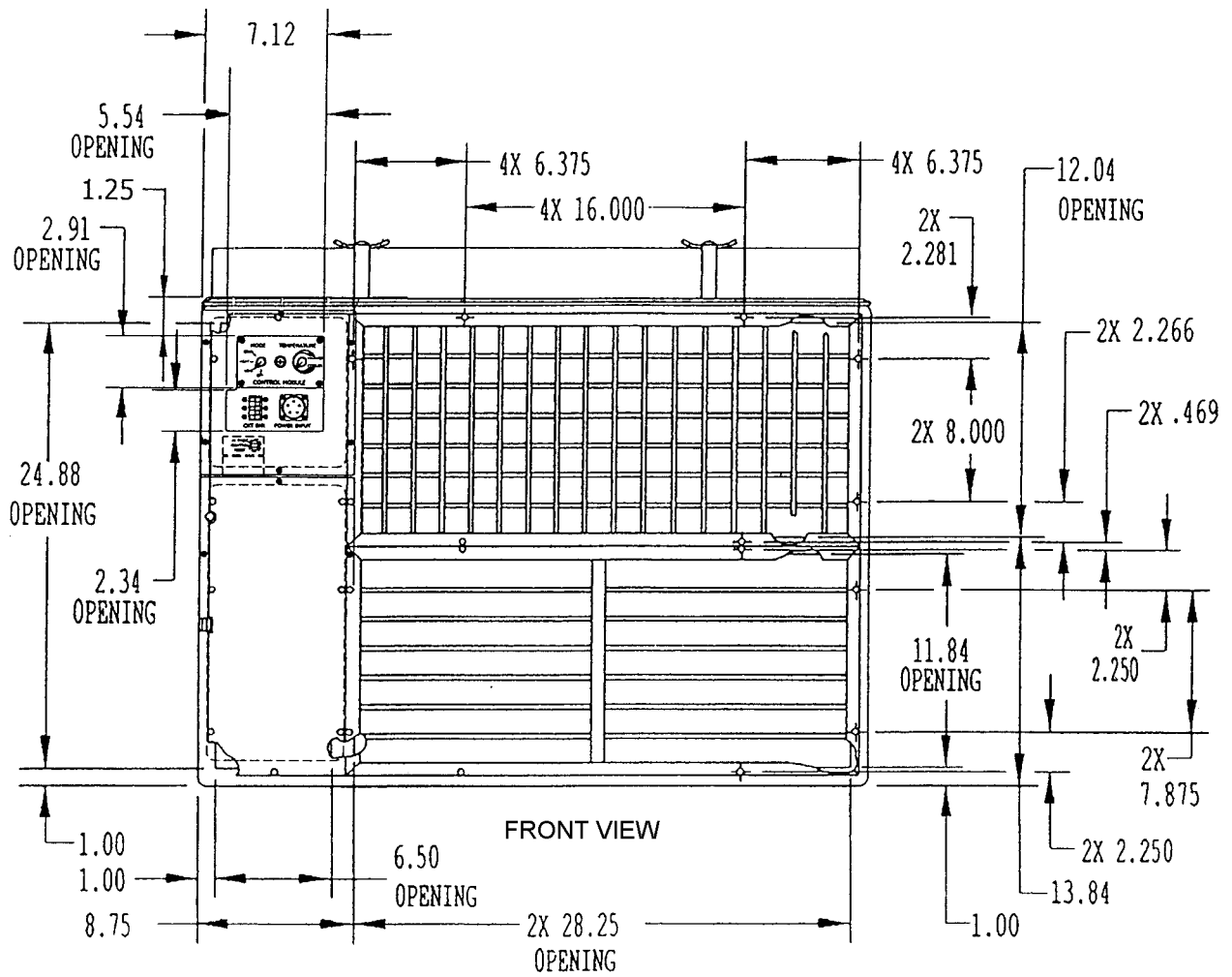

Installation Dimensions

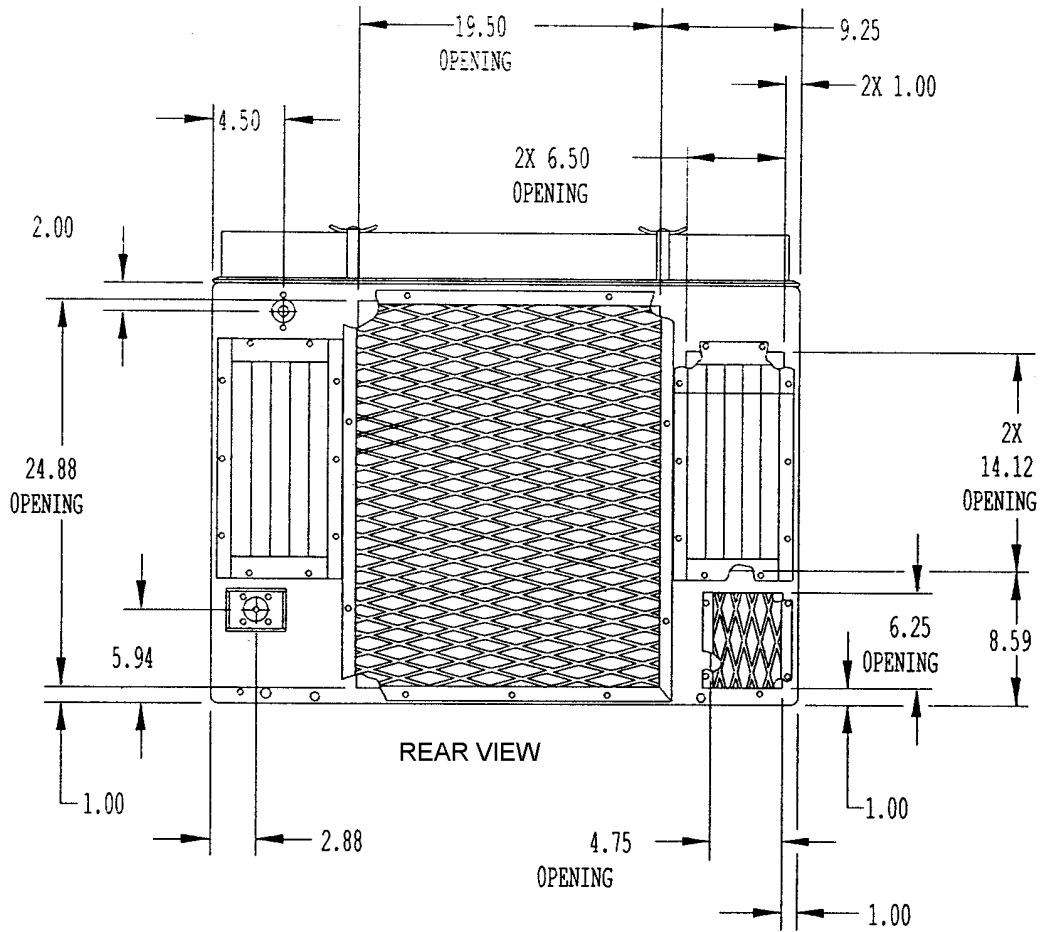

TOP VIEW

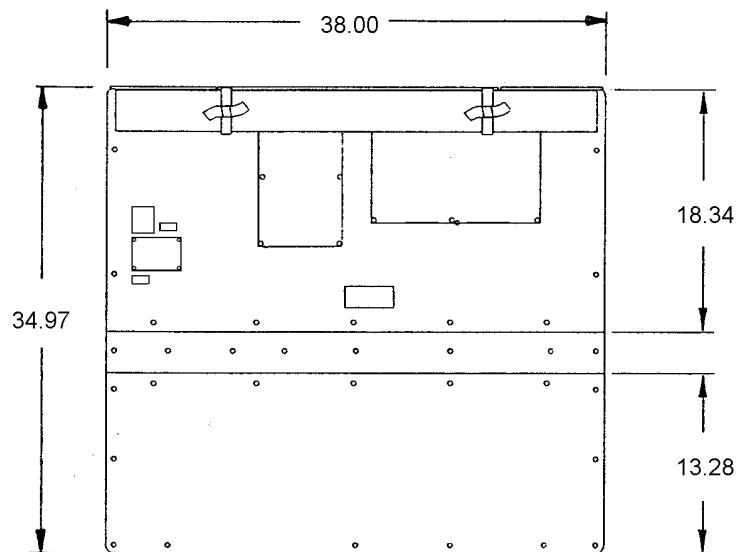

Installation Dimensions

END OF TASK

UNIT PREVENTIVE MAINTENANCE CHECKS AND SERVICES (PMCS)

0016-00

THIS WORK PACKAGE COVERS:

Introduction, PMCS

INITIAL SETUP:

Maintenance Level

Unit

Equipment Condition

Main power source is disconnected.

INTRODUCTION

General

To ensure that the air conditioner is ready for operation at all times, it must be inspected systematically so that the defects may be discovered and corrected before the result is serious damage or failure. Defects discovered during operation of the unit shall be noted for future corrections to be made as an operation has ceased. Stop operation which would damage the equipment if operation were to continue. All deficiencies and shortcomings shall be recorded together with the corrective action taken on DA Form 2404 or DA Form 5988E, Equipment Inspection and Maintenance Inspection Worksheet, at the earliest opportunity. If your equipment fails to operate, troubleshoot with proper equipment. Report any deficiencies using proper forms. See DA PAM 738-750.

PREVENTIVE MAINTENANCE CHECKS AND SERVICES (PMCS) TABLE

WARNING

Disconnect air conditioner power supply.

WARNING

Dry cleaning solvent (Item 16, WP 0121-00) used to clean parts is potentially dangerous to personnel and property. Avoid repeated and prolonged skin contact. Do not use near open flame or excessive heat. Flash point of solvent is 100°F (38°C).

WARNING

Do not use compressed air for cleaning purposes, except where reduced to less than 30 psi (2.1 kg/cm²) and then only with effective chip guarding and personal protective equipment.

”Interval” Column. Weekly and quarterly intervals are shown opposite the appropriate check. A weekly check is performed weekly, If the check is accomplished quarterly, it is shown as a quarterly interval.

Table 1. Unit Preventive Maintenance Checks and Services (PMCS)

ITEM NO.	INTERVAL	ITEM TO BE CHECKED OR SERVICED	PROCEDURE	EQUIPMENT NOT READY/AVAILABLE IF:
1	Weekly	Evaporator Air Intake Filter and Evaporator Air Intake Louver	<ol style="list-style-type: none"> 1. Remove screw (1), washers (2) and (3) to release evaporator air intake louver from unit. Remove air filter (5) from clip inside louver casing. <hr/> <p style="text-align: center;">WARNING</p> <hr/> <p>Dry cleaning solvent (Item 16, WP 0121-00) used to clean parts is potentially dangerous to personnel and property. Avoid repeated and prolonged skin contact. Do not use near flame or excessive heat. Flash point of solvent is 100°F (38°C).</p> <ol style="list-style-type: none"> 2. Inspect air filter (5) for damage. Replace if damaged. 3. Clean air filter (5) with mild soap and water solution. 4. Inspect louver (4) for bent blades. Straighten or replace. 5. Lubricate air filter (5) with filter-kote (Item 17, WP 0121-00). Drain off excessive oil. 	Items are damaged, missing or clogged.

Table 1. Unit Preventive Maintenance Checks and Services (PMCS) - Continued

ITEM NO.	INTERVAL	ITEM TO BE CHECKED OR SERVICED	PROCEDURE	EQUIPMENT NOT READY/AVAILABLE IF:
2	Weekly	Evaporator Air Intake Filter and Evaporator Air Intake Louver – Continued Evaporator Air Discharge Louver	<ol style="list-style-type: none"> 6. Position air filter (5) into louver housing (4). Secure filter with clip (8) inside louver casing. 7. Install evaporator air intake louver (4) with screw (1) and washers (2) and (3). <ol style="list-style-type: none"> 1. Check louver (3) for dirt or damage. 2. Clean or replace damaged parts. 3. Inspect louver for bent blades. Straighten or replace. <p style="text-align: center;">————— WARNING —————</p> <p>Dry cleaning solvent (Item 16, WP 0121-00) used to clean parts is potentially dangerous to personnel and property. Avoid repeated and prolonged skin contact. Do not use near open flame or excessive heat. Flash point of solvent is 100°F (38°C).</p>	Louver is missing or needs to be replaced.
3	Quarterly	Mist Eliminator	 <ol style="list-style-type: none"> 1. Remove top cover. See WP 0019-00. 2. Slide mist eliminator (1) out of the mist eliminator holder. 3. Inspect mist eliminator (1) for damage. Replace if damaged. 4. Clean mist eliminator (1). 5. Install mist eliminator (1) in holder. 	Items are damaged, missing or clogged.

Table 1. Unit Preventive Maintenance Checks and Services (PMCS) - Continued

ITEM NO.	INTERVAL	ITEM TO BE CHECKED OR SERVICED	PROCEDURE	EQUIPMENT NOT READY/AVAILABLE IF:
4	Quarterly	Evaporator and Condenser Fans and Motors	<ol style="list-style-type: none"> 1. Remove covers. See WP 0019-00. 2. Inspect evaporator motor (1), condenser motors (2) and impellers (3) and (4) for security of attachment, rubbing and free turning. 3. Check wiring for damage. 4. Replace damaged impellers (3) or (4) or motors (1 & 2) (WP 0033-00). 	Items are loose or damaged.

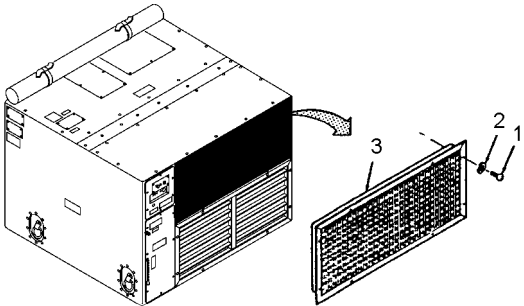
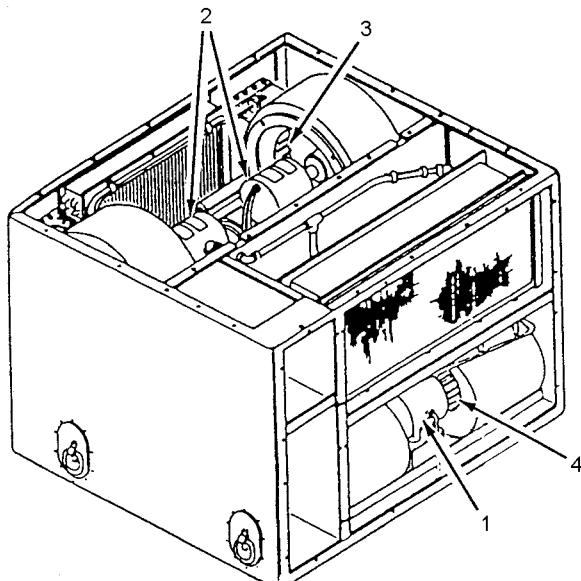
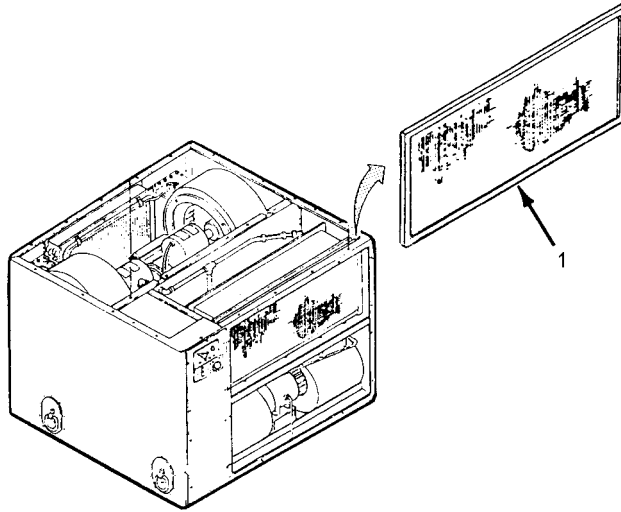

Table 1. Unit Preventive Maintenance Checks and Services (PMCS) - Continued

ITEM NO.	INTERVAL	ITEM TO BE CHECKED OR SERVICED	PROCEDURE	EQUIPMENT NOT READY/AVAILABLE IF:
5	Quarterly	Heaters	<p style="text-align: center;">————— WARNING —————</p> <p>Disconnect air conditioner power supply before doing any maintenance work on the unit.</p> <ol style="list-style-type: none"> 1. Remove covers. See WP 0019-00. 2. Check for breaks in wiring and insulation. Tighten loose connections. 3. Check heating elements for damage. 4. Clean heating elements. 5. Replace heating elements if damaged. See WP 0028-00. 	Items are loose, or wires or elements are damaged.

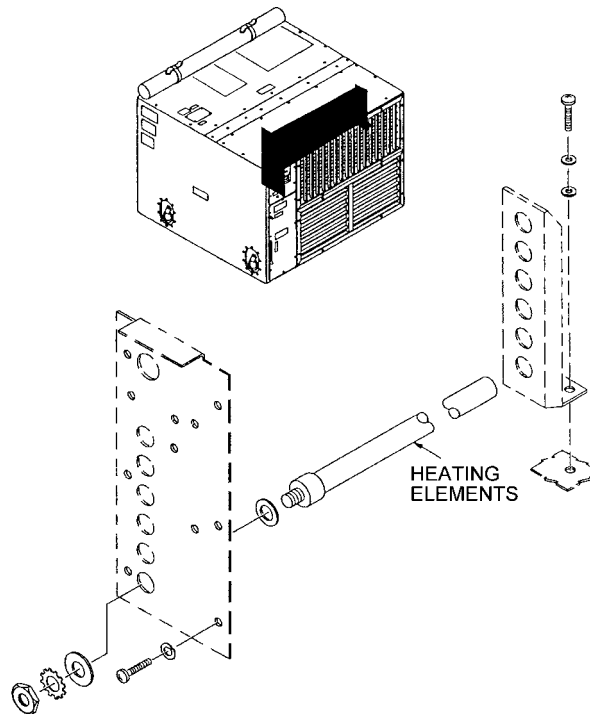

Table 1. Unit Preventive Maintenance Checks and Services (PMCS) - Continued

ITEM NO.	INTERVAL	ITEM TO BE CHECKED OR SERVICED	PROCEDURE	EQUIPMENT NOT READY/AVAILABLE IF:
6	Quarterly	Evaporator Coil and Condenser Coil	<ol style="list-style-type: none"> 1. Inspect coils for dirt or damage. Clean or report damage to Direct Support Maintenance personnel. 2. Inspect coils and tubing joints for leaks. Report damage to Direct Support Maintenance personnel. 	Item is dirty, damaged or leaking refrigerant.
 <p>The diagram shows a top-down view of the unit's interior. A label 'CONDENSER COIL' points to a large, rectangular coil on the left side. Another label 'EVAPORATOR COIL' points to a smaller coil located at the bottom right of the unit's interior.</p>				
7	Quarterly	Condensate Drain Lines and Openings	<ol style="list-style-type: none"> 1. Inspect condensate drain tubes and openings for blockage and bacteria growth. See WP 0029-00. 	Drain tubes are blocked.
 <p>The diagram illustrates the condensate drain system. It shows a top-down view of the unit with a curved arrow pointing to a drain tube. Below the unit, a detailed view of the drain tubes is shown, with a label 'DRAIN TUBES' pointing to the main horizontal pipe. The diagram shows the path of the drain tubes from the unit to the exterior.</p>				

Table 1. Unit Preventive Maintenance Checks and Services (PMCS) - Continued

ITEM NO.	INTERVAL	ITEM TO BE CHECKED OR SERVICED	PROCEDURE	EQUIPMENT NOT READY/AVAILABLE IF:
8	Quarterly	Louver Assembly and Actuator Cables	<ol style="list-style-type: none"> 1. Remove rear cover. See WP 0019-00. 2. Check that both cables and louvers operate smoothly and without binding (Requires unit operation). 3. Lubricate moving parts with small amount of oil (Item 14, WP 0121-00). 4. Check for loose or missing mounting hardware, bent louver or mechanical parts. 	Actuator inoperative.
9	Quarterly	Control Box	<ol style="list-style-type: none"> 1. Pull out control box. Check for loose or disconnected wiring, cracks, breaks or burns. See WP 0034-00. 2. Check for loose or missing hardware. 	Disconnected wires, loose or missing hardware.
10	Annually	Coils (Solenoid)	<ol style="list-style-type: none"> 1. Remove rear cover. See WP 0019-00. 2. Check wire leads for cracks, breaks or burns. 	Bad wiring.
11	Annually	All wiring terminals and electrical components	<ol style="list-style-type: none"> 1. Remove covers and control box. 2. Check wire leads for cracks, breaks, burns, rubbing and chaffing. 3. Check wiring clamp tie-down for loose or missing hardware. 4. Check tightness of all electrical terminals and connections. 5. Check electrical components for cracks, burn or electrical arcing or tracking. 	Repair or replace if any defects are found. Repair or replace if any defects are found.

END OF TASK

**UNIT MAINTENANCE
MECHANICAL REPAIRS AND ELECTRICAL REPAIRS**

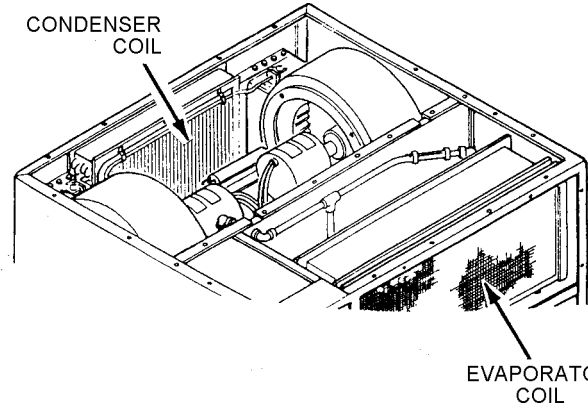
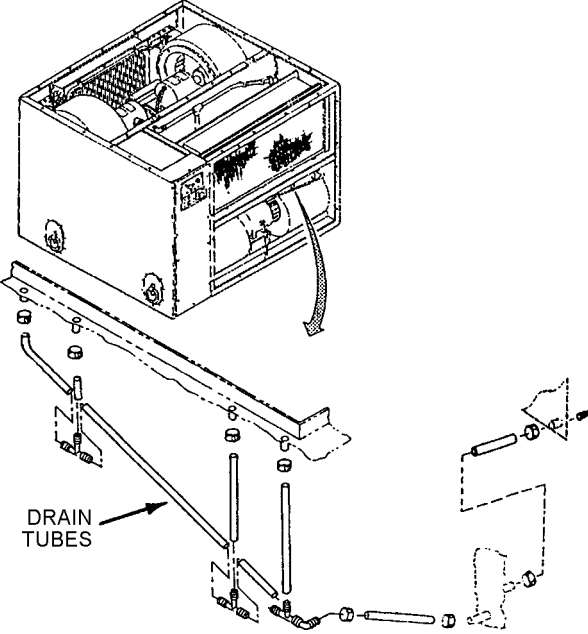
0017-00

WARNING

Disconnect air conditioner power supply.

Maintenance of Mechanical Parts

The mechanical maintenance covered in this chapter include:

Canvas Cover	WP 0018-00
Condensate Drain Assembly	WP 0029-00
Condenser Air Discharge Louvers	WP 0021-00
Condenser Coil Guard.....	WP 0024-00
Condenser Coil Service.....	WP 0041-00
Evaporator Air Intake Filter	WP 0023-00
Evaporator Coil Service	WP 0040-00
Evaporator Louvers	WP 0020-00
Housing Service	WP 0042-00
Information Plates	WP 0025-00
Installation Hardware	WP 0044-00
Louver Actuator Cables	WP 0032-00
Mist Eliminator	WP 0026-00
Panels	WP 0019-00
Ventilation Guard and Ventilation Air Filter	WP 0022-00

Maintenance of Electrical System

The electrical system is made up of:

Circuit Breaker	WP 0033-00
Coil (Solenoid Valve)	WP 0039-00
Condenser Fan Motors	WP 0031-00
Evaporator Fan Motor	WP 0030-00
Heater Cutout Switches.....	WP 0027-00
Heater Subassembly	WP 0028-00
Junction Box Assembly	WP 0035-00
Main Power Input Connector	WP 0043-00
Remote Control Module.....	WP 0034-00
Terminal Boards TB1 and TB5	WP 0037-00
Transformer.....	WP 0036-00
Unit Wiring	WP 0038-00

Testing and Inspecting The Electrical System

WARNING

Disconnect air conditioner power supply.

Troubleshooting procedures for testing the electrical system to isolate causes of trouble are discussed in WP 0014-00. More detailed test information is contained in specific paragraphs about the electrical components.

Use a multimeter set on low-resistance range to test for continuity.

Use an insulation tester or a multimeter set on a high-resistance range to test for short circuits between the circuit in a component and the outside casing of the component.

When testing an electrical component, check for visible damage, and inspect all wiring in the area for damage, overheating or loose connections.

END OF TASK

CANVAS COVER – SERVICES

0018-00

THIS WORK PACKAGE COVERS:

Removal, Inspection and Cleaning, Installation

INITIAL SETUP:

Maintenance Level

Unit

Materials/Parts

Cloth, lint free (Item 9, WP 0121-00)

Dry cleaning solvent (Item 16, WP 0121-00)

Tools and Special Tools

Tool Kit, General Mechanics (Item 1, Table 2, WP 0118-00)

WARNING

Disconnect air conditioner power supply.

REMOVAL

1. Loosen tie strap (1) on the canvas cover (2) (if rolled) and unroll cover.

NOTE

Do not leave rolled up when wet. Spread canvas cover out flat until it is dry.

2. Remove three screws (3), three lock washers (4) and three flat washers (5) to remove canvas cover (2) from top of unit (6).

INSPECTION AND CLEANING

1. Inspect for cuts, rips, tears, and fraying.

WARNING

Clean parts in a well ventilated area. Avoid inhalation of solvent fumes and prolonged exposure of skin to cleaning solvent. Wash exposed skin thoroughly. Dry cleaning solvent, P-D-680, used to clean parts is potentially dangerous to personnel and property. Avoid repeated and prolonged skin contact. Do not use near open flame or excessive heat. Flash point of solvent is 100°F to 138°F (38°C to 59°C).

2. Inspect for stains, clean with detergent and water or dry cleaning solvent (Item 16, WP 0121-00) and lint free cloth.

NOTE

Do not roll up immediately after cleaning. Spread canvas cover out flat until it is dry.

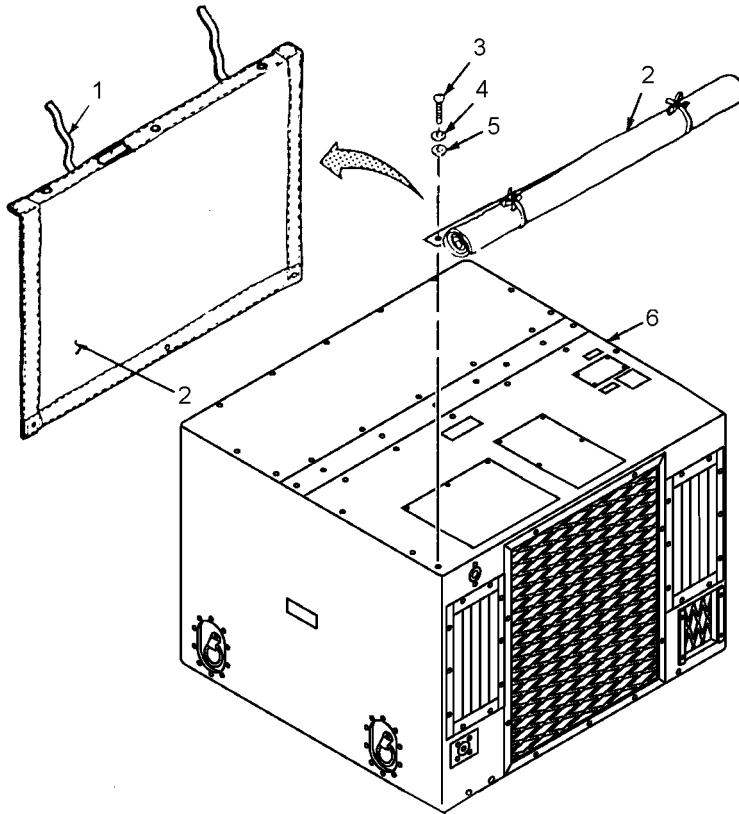
**REPAIR**

1. Repair minor fabric rips, cuts, tears or punctures by applying a patch of duct tape inside surface.
2. If damage to fabric cover is extensive, replace fabric cover.

INSTALLATION

1. Position canvas cover (2) on top panel (6) and align cover with corresponding holes.
2. Secure canvas cover (2) with three screws (3), three lockwashers (4), and three flatwashers (5).
3. Button snap cover shut or roll up and tie with straps.

END OF TASK

PANELS UNIT MAINTENANCE

0019-00

THIS WORK PACKAGE COVERS:

Removal, Repair and Installation

INITIAL SETUP:

Maintenance Level

Unit Support

Tools and Special Tools

Tool Kit, General Mechanics (Item 1, Table 2, WP 0118-00)

Equipment Condition

Main power source is disconnected.
Canvas cover removed (WP 0018-00).

Materials/Parts

Flexible elastomeric thermal insulation (Item 20, Table 1, WP 0121-00)
Warm, soapy water
Filter-kote or oil (Item 17, Table 1, WP 0121-00)
Adhesive (Item 18, Table 1, WP 0121-00)
Dry cleaning solvent (Item 16, Table 1, WP 0121-00)

WARNING

Disconnect air conditioner power input connector.

REMOVAL

1. Remove nine screws (1), five screws (2) and front cover panel (3) with its thermal insulation (4).
2. Remove nine screws (5), five screws (6), and rear cover panel (7) with its insulation (8).
3. Remove eight screws (9) and center cover panel (10) with its thermal insulation (11).

REPAIR**Top Panels**

1. Inspect for bent panels, loose or missing thermal insulation.
2. Clean dirty panels with warm, soapy water.
3. Straighten or replace damaged panels.

WARNING

MMM-A-121 Adhesive is flammable and its vapors can be explosive. Repeated or prolonged skin contact or inhalation of vapors can be toxic. Use in a well ventilated area and keep away from sparks or flame. Use goggles, gloves, and apron when appropriate.

4. Secure loose thermal insulation with adhesive (Item 18, Table 1, WP 0121-00).

WARNING

Clean parts in a well-ventilated area. Avoid inhalation of solvent fumes and prolonged exposure of skin to cleaning solvent. Wash exposed skin thoroughly. Dry cleaning solvent, P-D-680 Type III, which is used to clean parts, is potentially dangerous to personnel and property. Avoid repeated and prolonged skin contact. Do not use near open flame or excessive heat. Flash point of solvent is 100°F to 138°F (38°C to 59°C).

5. Clean area using dry cleaning solvent (Item 16, Table 1, WP 0121-00).

WARNING

MMM-A-121 Adhesive is flammable and its vapors can be explosive. Repeated or prolonged skin contact or inhalation of vapors can be toxic. Use in a well-ventilated area and keep away from sparks or flame. Use goggles, gloves, and apron when appropriate.

6. Replace damaged thermal insulation (4), (8) and (11) with flexible thermal insulation (Item 20, Table 1, WP 0121-00) and adhesive (Item 18, Table 1, WP 0121-00).
7. Install panels using screws (1), (2), (5), (6) and (9).

REPAIR - Continued**Canvas Cover Repair**

1. Repair any rips in canvas or seams.
2. Replace canvas cover if heavily damaged.
3. Install canvas cover. Refer to WP 0018-00.

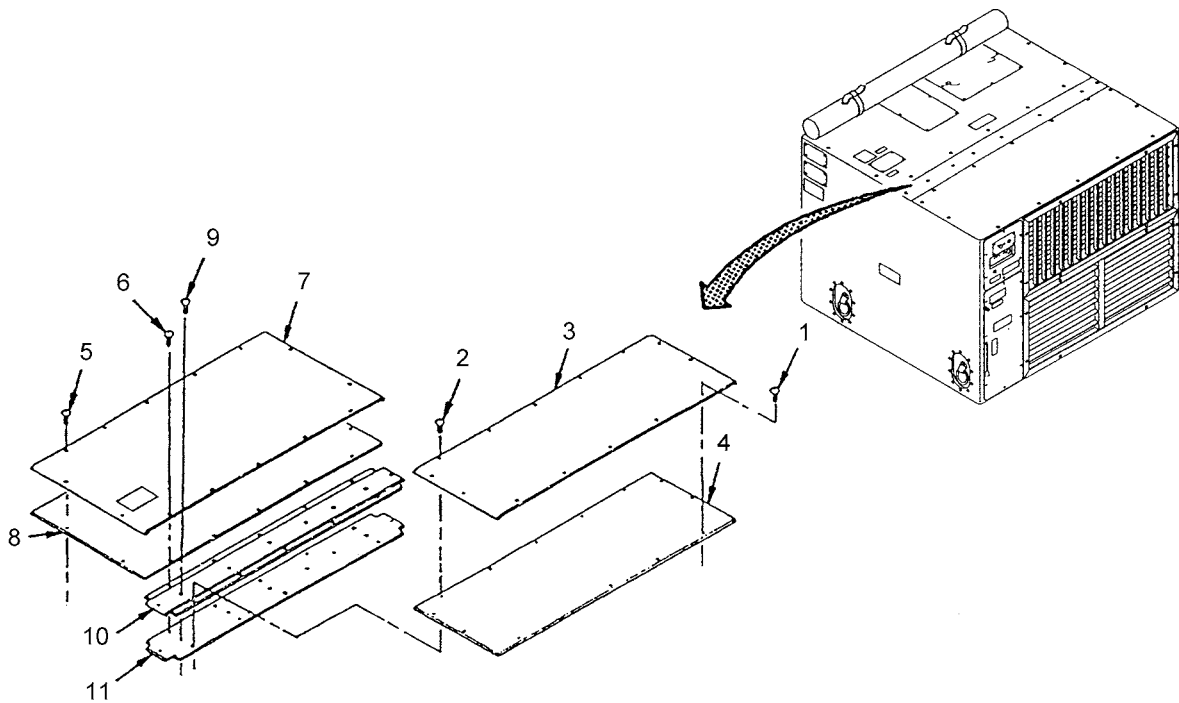
**END OF TASK**

EVAPORATOR LOUVERS – UNIT MAINTENANCE

0020-00

THIS WORK PACKAGE COVERS:

Removal, Inspection, Cleaning and Installation

INITIAL SETUP:**Maintenance Level**

Unit

Materials/Parts

Cloth, lint free (Item 9, WP 0121-00)

Dry cleaning solvent (Item 16, WP 0121-00)

Warm soapy water

Tools and Special Tools

Tool Kit, General Mechanics (Item 1, Table 2, WP 0118-00)

WARNING

Disconnect air conditioner power input connector.

REMOVAL**Evaporator Air Intake Louver**

1. Remove eight screws (1) and eight lockwashers (2), securing louver (4) with filter (5) to housing.
2. Remove louver and filter assembly (3).
3. Remove air intake filter (5) from clips (7) and (8) on louver (4).

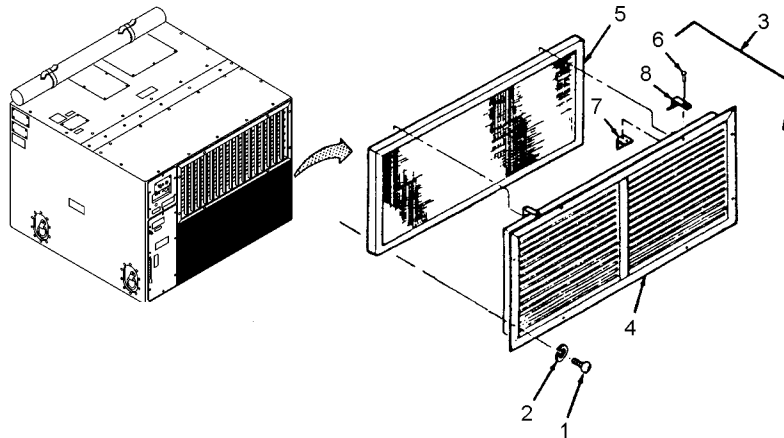
**Evaporator Air Discharge Louver**

1. Remove eight screws (9) and eight lockwashers (10), securing louver (11) to housing.
2. Remove louver (11).

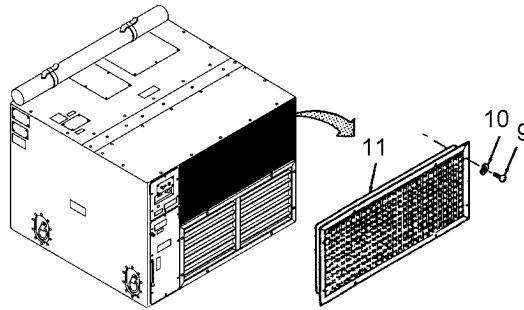

INSPECTION

1. Inspect louver blades for bends or damage and straighten.
2. Inspect evaporator air intake louver and evaporator air discharge louver for other damage.

CLEANING

1. Clear obstructions from louver blades using dry cleaning solvent or warm soapy water.
2. Clean louver blades of obstructions.

INSTALLATION

Evaporator Air Intake Louver

1. Install air intake filter (5) into clips (7) and (8) on louver (4).
2. Align and secure louver and filter assembly (3) to housing using eight screws (1) and eight lockwashers (2).

Evaporator Air Discharge Louver

Align and secure louver (11) to housing using eight screws (9) and eight lockwashers (10).

END OF TASK

CONDENSER AIR DISCHARGE LOUVER UNIT MAINTENANCE

0021-00

THIS WORK PACKAGE COVERS:

Removal, Cleaning, Repair and Installation

INITIAL SETUP:

Maintenance Level

Unit

Materials/Parts

Dry cleaning solvent (Item 16, WP 0121-00)

Tools and Special Tools

Tool Kit, General Mechanics (Item 1, Table 2, WP 0118-00)

Equipment Condition

Canvas cover detached (WP 0018-00).

Rear top cover removed (WP 0019-00).

WARNING

Disconnect air conditioner power input connector.

REMOVAL (Refer to Figure 1)

1. Remove two screws (1), two posts (2) and four nuts (3) to disconnect cables (4) from louvers (7) and (8).
2. Remove ten screws (5) and ten lockwashers (6) from each louver (7) and (8).

CLEANING

Clean with warm soapy water or dry cleaning solvent (Item 16, WP 0121-00).

WARNING

Clean parts in a well-ventilated area. Avoid inhalation of solvent fumes and prolonged exposure of skin to cleaning solvent. Wash exposed skin thoroughly. Dry cleaning solvent, P-D-680 Type III, which is used to clean parts, is potentially dangerous to personnel and property. Avoid repeated and prolonged skin contact. Do not use near open flame or excessive heat. Flash point of solvent is 100°F to 138°F (38°C to 58°C).

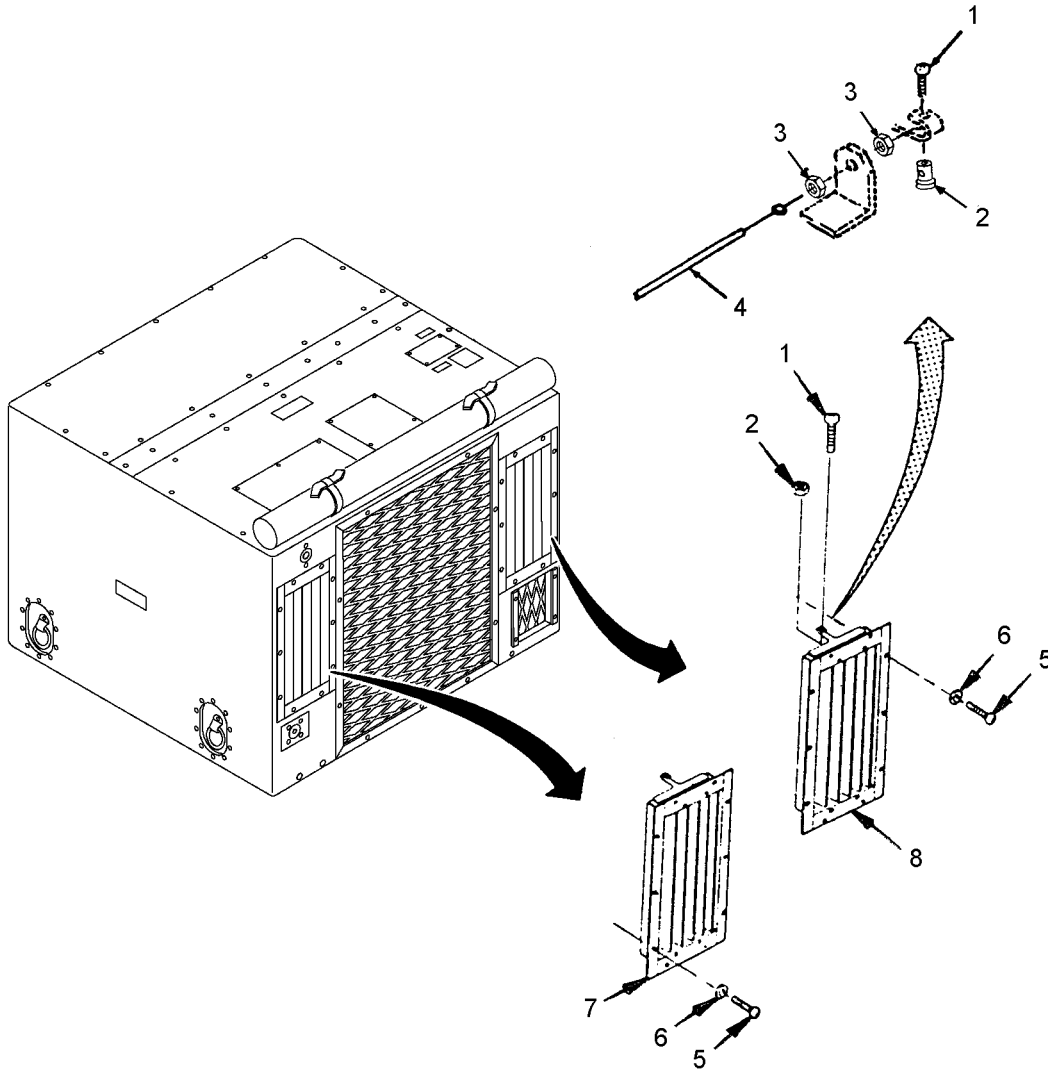

Figure 1

REPAIR**Disassembly (Refer to Figure 2)**

1. Remove twelve screws (9) and louver frame (10).
2. Remove lower bearing plate (11) and five bearings (12).
3. Disassemble five pins (13), five washers (14), connecting link (15), upper bearing plate (16), five bearings (17), and five louver blades (18).
4. Remove five rivets (19) and then disassemble link (20), and five louver blade arms (21).

ASSEMBLY (Refer to Figure 2)

1. Inspect all parts, replace damaged items.
2. Assemble five louver blade arms (21), link (20), and then install five rivets (19).
3. Install five louver blades (18), five bearings (17), connecting link (15), five washers (14) and five pins (13) onto upper bearing plate (16).
4. Install five bearings (12) and lower bearing plate (11).
5. Install louver frame (10) and twelve screws (9).

INSTALLATION (Refer to Figure 1)

1. Install left condenser exhaust louver (8), ten lock washers (6), and ten screws (5).
2. Install right condenser exhaust louver (7), ten lock washers (6), and ten screws (5).
3. Place loops from cable (4) into louvers (7 and 8) and install two screws (1), two posts (2) and nuts (3).
4. Install rear panel and canvas cover. See WP 0018-00 and WP 0019-00.

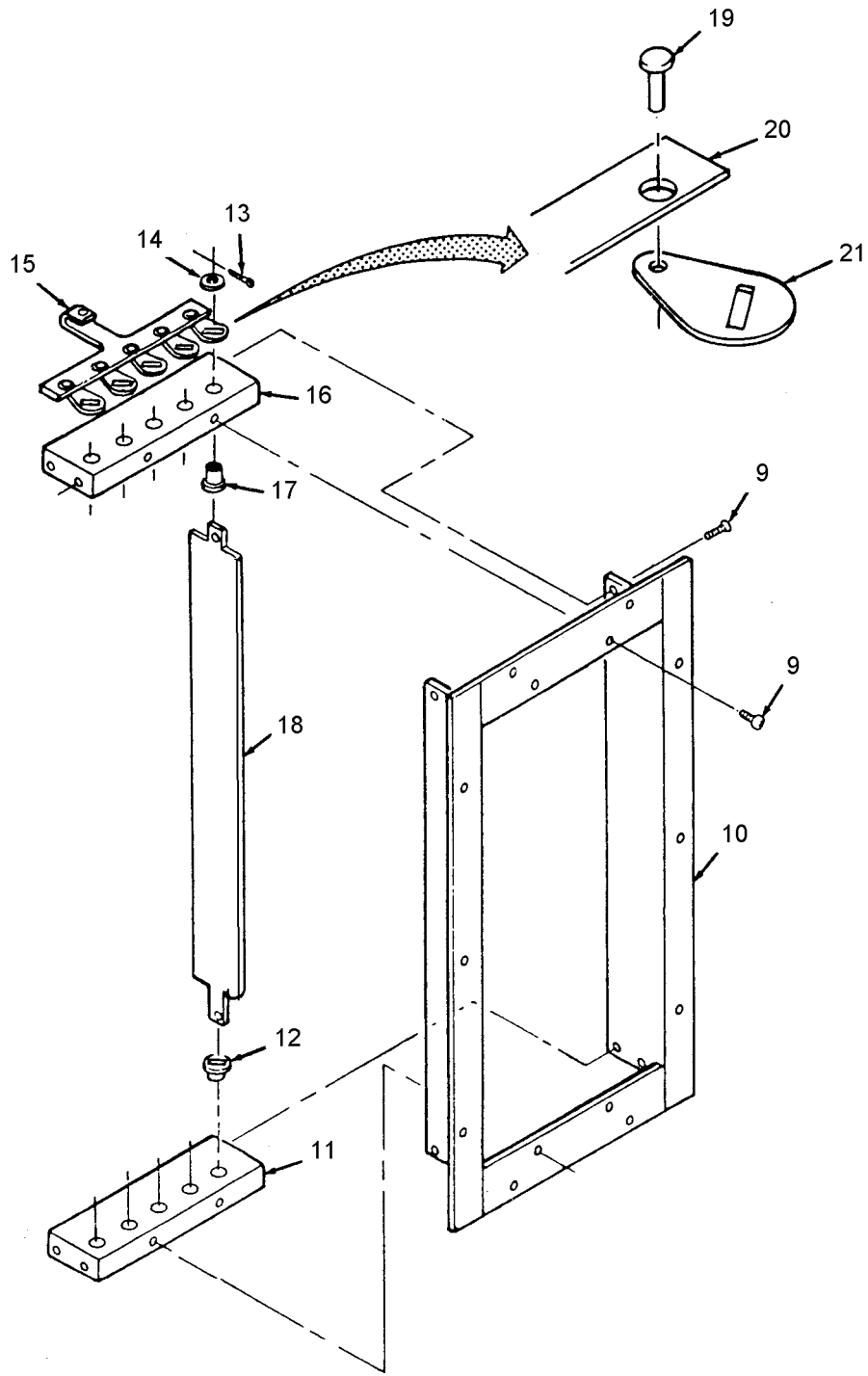

Figure 2

END OF TASK

VENTILATION GUARD AND VENTILATION AIR FILTER UNIT MAINTENANCE

0022-00**THIS WORK PACKAGE COVERS:**Removal, Inspection, Service, and Installation

INITIAL SETUP:**Maintenance Level**

Unit

Materials/Parts

Dry cleaning solvent (Item 16, WP 0121-00)

Warm soapy water

Tools and Special Tools

Tool Kit, General Mechanics (Item 1, Table 2, WP 0118-00)

Equipment ConditionCanvas cover rolled up and tied (WP 0018-00).

WARNING

Disconnect air conditioner power input connector.

NOTE

The ventilation guard and ventilation air filter mounted on the rear wall of the housing, covers the fresh air inlet opening to prevent airborne matter from entering the air conditioner. This unit was designed for use with CBR.

REMOVAL

1. Remove four screws (1), four lockwashers (2), and ventilation guard (3).
2. Remove ventilation filter (4) from unit (5).

INSPECTION

Inspect ventilation filter for dirt or debris that cannot be removed without damaging filter. If filter is unable to be cleaned, replace it with a new filter.

SERVICING

1. Inspect filter (5). Replace damaged filter. Clean with warm soapy water or dry cleaning solvent (Item 16, WP 0121-00). Hose with water in both directions.
2. Replace filter having breaks, tears, excess accumulations of dirt or grease, or other major damage.
3. Lubricate air filter with filter-kote (Item 17, WP 0121-00).

INSTALLATION

1. Install ventilation air filter (4) into unit (5).
2. Install ventilation guard (3), for lockwashers (2), and four screws (1).

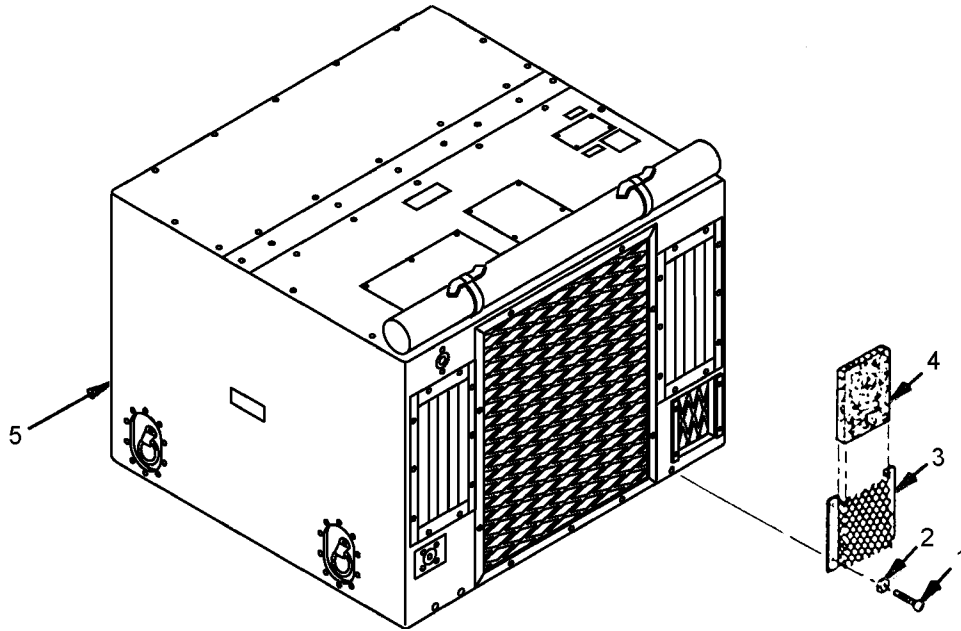

END OF TASK

EVAPORATOR AIR INTAKE FILTER – UNIT MAINTENANCE

0023-00

THIS WORK PACKAGE COVERS:

Removal, Cleaning, and Installation

INITIAL SETUP:

Maintenance Level

Unit

Materials/Parts

Hose, with running water

Filter-kote or oil (Item 17, WP 0121-00)

Dry cleaning solvent (Item 16, WP 0121-00)

Tools and Special Tools

Tool Kit, General Mechanics (Item 1, Table 2, WP 0118-00)

Equipment Condition

Evaporator inlet louver removed (WP 0020-00).

WARNING

Disconnect air conditioner power input connector.

REMOVAL

Remove air filter (5) from clips (7) and (8) on louver (4).

WARNING

Clean parts in a well-ventilated area. Avoid inhalation of solvent fumes and prolonged exposure of skin to cleaning solvent. Wash exposed skin thoroughly. Dry cleaning solvent, P-D-680, used to clean parts, is potentially dangerous to personnel and property. Avoid repeated and prolonged skin contact. Do not use near open flame or excessive heat. Flash point of solvent is 100°F to 138°F (38°C to 59°C).

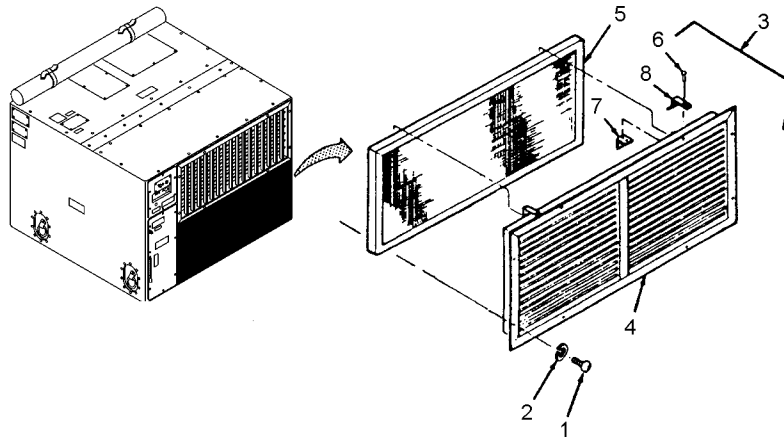
REMOVAL - Continued**CLEANING**

1. Inspect filter (5). Replace damaged filter. Clean with warm soapy water or dry cleaning solvent (Item 16, WP 0121-00). Hose with water in both directions.
2. Replace filter having breaks, tears, excess accumulations of dirt or grease, or other major damage.
3. Lubricate air filter with filter-kote (Item 17, WP 0121-00).

INSTALLATION

1. Position air filter into louver and press filter into clips (7) and (8).
2. Install evaporator air intake louver. (See WP 0020-00).

END OF TASK

CONDENSER COIL GUARD UNIT MAINTENANCE

0024-00

THIS WORK PACKAGE COVERS:

Removal, Cleaning, and Installation

INITIAL SETUP:

Maintenance Level

Unit

Materials/Parts

Dry Cleaning solvent (Item 16, WP 0121-00)

Tools and Special Tools

Tool Kit, General Mechanics (Item 1, Table 2, WP 0118-00)

Equipment Condition

Main power source disconnected.

WARNING

Disconnect air conditioner power input connector.

REMOVAL

Remove condenser guard (4) by removing eight screws (1) and eight lockwashers (2) and eight fasteners (3).

CLEANING

1. Straighten condenser coil guard bent frame.
2. Clean with warm soapy water or dry cleaning solvent. (Item 16, WP 0121-00)

WARNING

Clean parts in a well-ventilated area. Avoid inhalation of solvent fumes and prolonged exposure of skin to cleaning solvent. Wash exposed skin thoroughly. Dry cleaning solvent, P-D-680 Type III, which is used to clean parts, is potentially dangerous to personnel and property. Avoid repeated and prolonged skin contact. Do not use near open flame or excessive heat. Flash point of solvent is 100°F to 138°F (38°C to 58°C).

INSTALLATION

Install condenser guard (4) using eight lockwashers (2), eight fasteners (3) and eight screws (1).

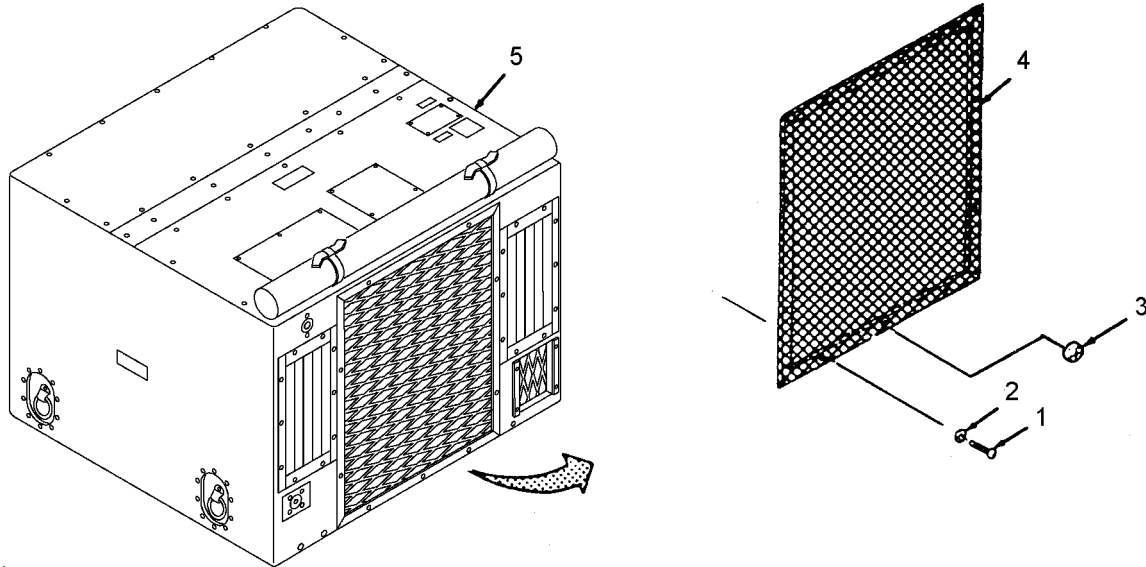

END OF TASK

INFORMATION PLATES UNIT MAINTENANCE

0025-00

THIS WORK PACKAGE COVERS:

Removal, and Installation

INITIAL SETUP:

Maintenance Level

Unit

Materials/Parts

Dry cleaning solvent (Item 16, WP 0121-00)
Warm soapy water

Tools and Special Tools

Tool Kit, General Mechanics (Item 1, Table 2, WP 0118-00)

Equipment Condition

Main power source disconnected.

WARNING

Disconnect air conditioner power input connector.

NOTE

Remove and replace only badly damaged, unreadable information plates. Refer to WP 0002-00 for text on each plate or decal.

REMOVAL

Decals

Using a flathead screwdriver, remove the following decals:

- High pressure charging valve decal (2)
- Charging valve access cover (3)
- Low pressure charging valve decal (4)
- Vent decal (7)
- Grounding lug decal (8)
- Caution grounding decal (9)
- Reset high pressure decal (10)
- Danger decal (11)
- Lift caution decal (12)
- Warning decal (13)
- Caution 208 volts decal (15)
- Caution connect ground decal (16)

REMOVAL-Continued**Plates**

Using a 1/8" diameter drill remove rivets from the following information plates:

Equipment data plate (1)

Refrigeration diagram plate (5)

Schematic diagram plate (6)

Warranty plate (14)

Remote control module plate (17) is removed during disassembly of control module. See WP 0034-00.

INSTALLATION

1. Clean area on side of unit where identification plates will be installed with soap and water.
2. Remove protective paper from back of new decal to expose sticky surface.
3. Align decal to proper position and press in place.
4. Secure information plates (1), (5), (6), and (14) with rivets (18).

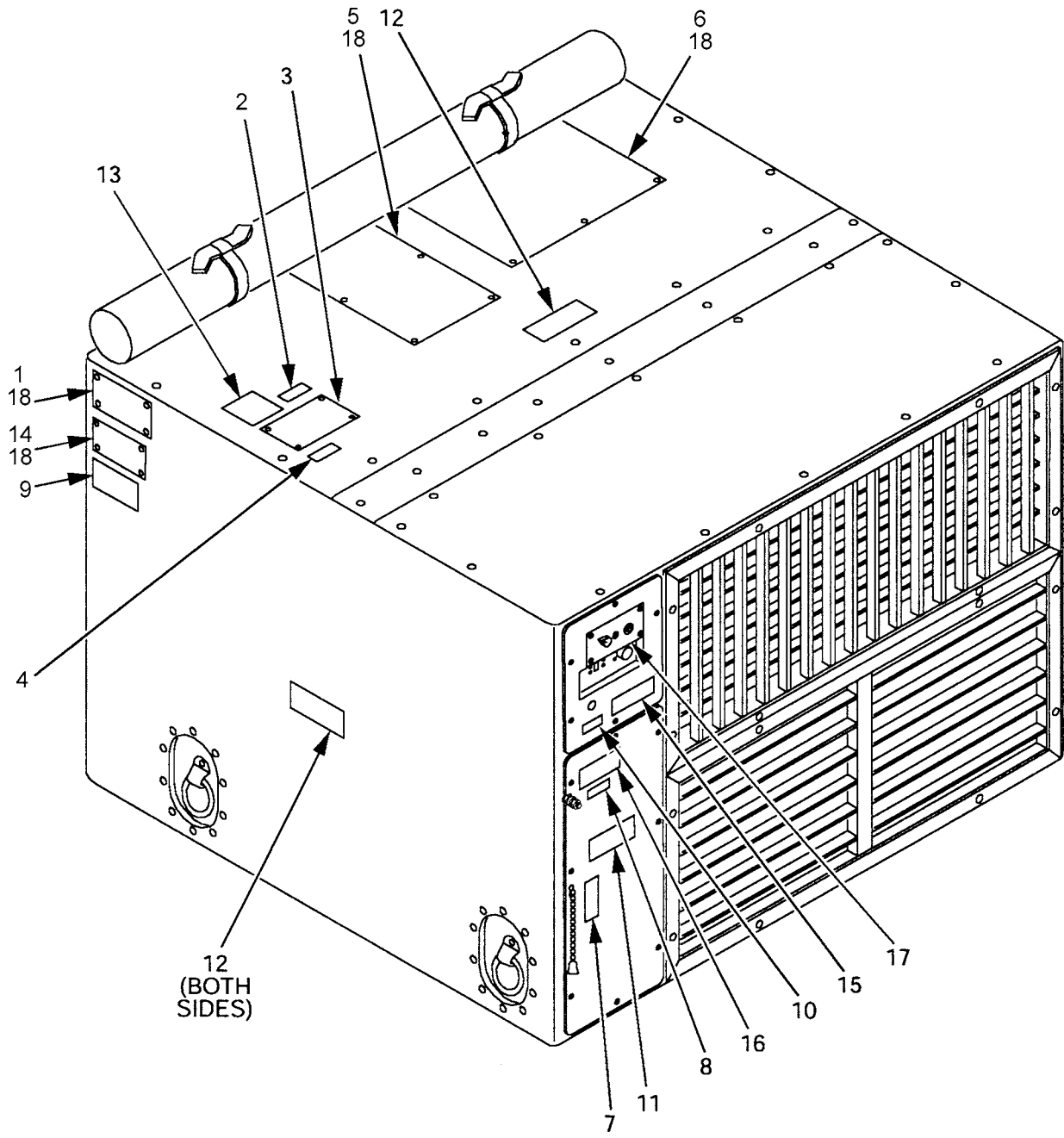

END OF TASK

MIST ELIMINATOR UNIT MAINTENANCE

0026-00

THIS WORK PACKAGE COVERS:

Removal, Cleaning, and Installation

INITIAL SETUP:**Maintenance Level**

Unit

Materials/Parts

Hose, with running water

Tools and Special Tools

Tool Kit, General Mechanics (Item 1, Table 2, WP 0118-00)

Equipment Condition

Top panels and canvas cover removed (WP 0018-00 and WP 0019-00).

Evaporator air louvers removed (WP 0020-00).

WARNING

Disconnect air conditioner power input connector.

REMOVAL

1. Remove top panels. Refer to WP 0018-00 and WP 0019-00.
2. Remove evaporator air louvers. Refer to WP 0020-00.
3. Slide mist eliminator (1) up and out of mist eliminator housing holder.

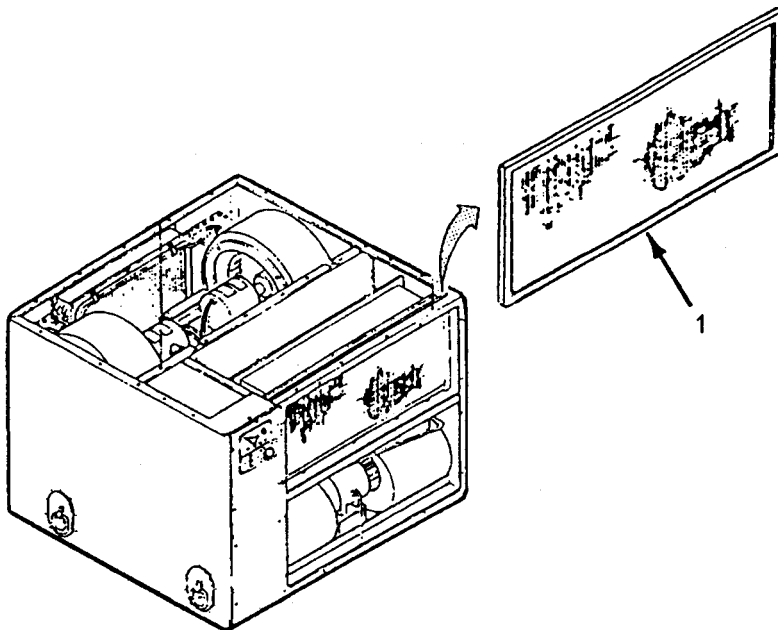

CLEANING

1. Inspect mist eliminator for dirt, bends or warped frame.
2. Clean mist eliminator (1) by hosing water through in opposite direction of airflow.
3. Replace bent or damaged mist eliminator.

INSTALLATION

1. Insert mist eliminator (1) into mist eliminator housing holder.

NOTE

Heed airflow direction arrow on mist eliminator frame.

2. Install top covers, canvas cover and evaporator air louvers. See WP 0018-00, WP 0019-00 and WP 0020-00.

END OF TASK

HEATER CUTOUT SWITCHES UNIT MAINTENANCE

0027-00

THIS WORK PACKAGE COVERS:

Inspection, Removal, Test and Installation

INITIAL SETUP:

Maintenance Level

Unit

Tools and Special Tools

Tool Kit, General Mechanics (Item 1, WP 0118-00)

Materials/Parts

150-watt lamp bulb or heat gun

Test Equipment

Multimeter

References

Schematic Diagram, WP 0122-00

Equipment Condition

Air conditioner shut down and cool.

Power disconnected from unit.

Top covers removed (WP 0019-00).

WARNING

Disconnect air conditioner power supply.

WARNING

Allow heating elements to cool for 15 minutes before touching.

INSPECTION

Inspect for wiring damage.

REMOVAL

1. Take out two screws (1) and two washers (2) to remove the high voltage heater cutout switch S3 (3) from switch bracket (4).
2. Take out two screws (5) and two washers (6) and remove the low voltage heater cutout switch S6 (7) from switch bracket (4).
3. Tag wire leads.

TEST**High and Low Voltage Heater Cutout Switches S3 and S6**

1. Using a multimeter on the lowest possible setting, test for continuity between contacts 1 and 2 and between contacts 3 and 4 on switch S3. See Schematic Diagram, WP 0122-00.
2. Using multimeter on lowest possible settings test for continuity between contacts 1 and 2 and between contacts 3 and 4 on switch S6.
3. Replace if defective.

INSTALLATION

1. Connect two leads to switch S6 (7) and remove tags.
2. Connect four leads to switch S3 (3) and remove tags.
3. Attach switch S6 (7) to bracket (4) with two screws (5) and two washers (6).
4. Attach switch S3 (3) to bracket (4) with two screws (1) and two washers (2).
5. Install top panels. See WP 0019-00.

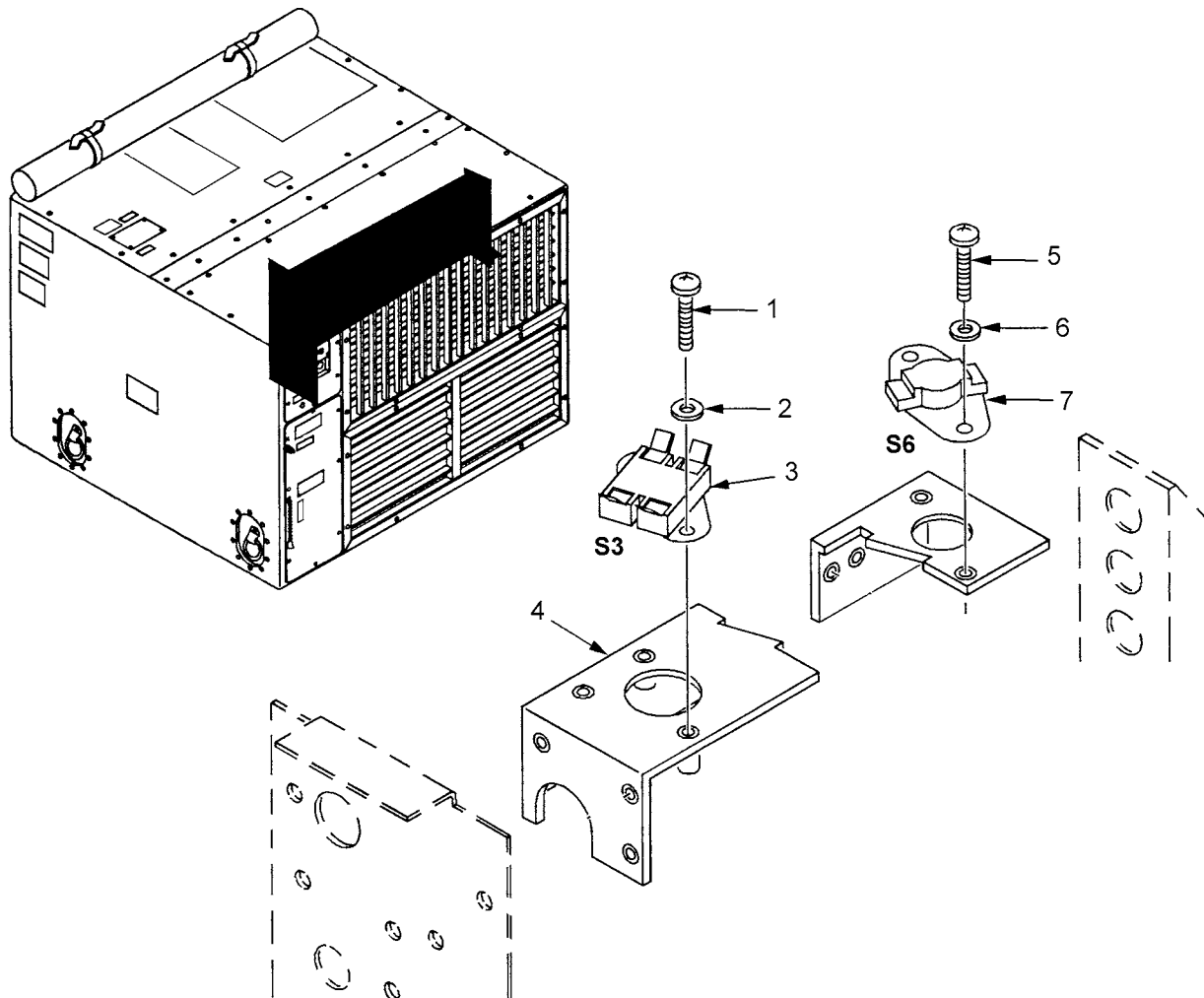

END OF TASK

HEATER SUBASSEMBLY – UNIT MAINTENANCE

0028-00

THIS WORK PACKAGE COVERS:

Inspection, Test, Removal, Repair, and Installation

INITIAL SETUP:

Maintenance Level

Unit

Tools and Special Tools

Tool Kit, General Mechanics (Item 1, Table 2, WP 0118-00)

Materials/Parts

Lint Free Cloth (Item 9, WP 0121-00)

Warm Soapy Water

References

Schematic Diagram, WP 0122-00

Heater Cutout Switches WP 0027-00

Test Equipment

Multimeter

Equipment Condition

Air conditioner shut down and cool.

Power disconnected from unit.

Top covers removed (WP 0019-00).

Circuit breaker panels, control module and junction box partially removed (WP 0033-00,

WP 0034-00 and WP 0035-00).

Heater cutout switches tested (WP 0027-00).

WARNING

Allow heating elements to cool for 15 minutes or more before touching.

WARNING

Disconnect air conditioner power supply.

INSPECTION**Heater Elements and Electrical Wiring**

1. Inspect for damage to elements (3) or leads (1 and 2).
2. Check heater element for continuity.
3. Replace damaged leads and bad elements.

Heater Support Brackets (7, 10 and 29)

1. Inspect for warping or cracking.
2. Replace as necessary.

Terminal Board (TB4)

1. Inspect TB4(17) for corrosion or damage.
2. Replace as necessary.

TEST

1. Test heater elements (3) by checking for continuity between the two electrical leads (1 and 2) of each heater element. Refer to schematic diagram WP 0122-00. Test can be performed at terminal board TB(17). If continuity does not exist, replace element.
2. Test heater cutout switches. See WP 0027-00.

REMOVAL

1. Tag and disconnect input power leads from terminal board TB4(17).
2. Remove six screws (8) and six lockwashers (9) securing heater support bracket (10) to housing.
3. Gently pull up and out the heater subassembly from housing.
4. For each heater element (3), remove nut (11), lockwasher (12), flat washer (13), and insulator (14) securing heater element (3) to heater support bracket (10).
5. Slide each heating element (3) from heater support bracket (10) and heating angle bracket (7).

NOTE

Do not remove tags from heater element wire.

6. Remove two screws (15) securing terminal board TB4(17) to bracket (10).
7. Remove terminal board TB4 from bracket (10).

REMOVAL - Continued

8. Bracket (29) and grommet (19) can remain in place unless damaged.
9. Refer to WP 0027-00 for unit maintenance of cutout switches (22) and (25).

INSTALLATION

1. Clean heater brackets (10 and 29) with warm soapy water and lint free cloth (Item 9, WP 0121-00).
2. Replace terminal board TB4(17) if terminals are missing or unserviceable.
3. Replace marker strip (18) if cracked, missing or cannot be easily read.
4. Insert heater elements (3) and insulator (14) into heater support bracket (11).
5. Secure each heater element (3) to heater support bracket (10) using flat washer (13), lockwasher (12) and nut (11).
6. If disassembled, secure cutout switch mounting bracket (29) with its switches (22 and 25) to heater support bracket (10) with three screws (26) and three lockwashers (27).
7. Slide heater angle bracket (7) over ends of heating elements (3).
8. Place the heater subassembly into the housing, line-up screw holes.
9. Secure heater support bracket (10) into unit using six screws (8) and six lockwashers (9).
10. Connect unit power leads to terminal board TB4(17) and remove tags.
11. Install junction box. See WP 0035-00.
12. Install circuit breaker panel and control module. See WP 0033-00 and WP 0034-00.
13. Install top covers. See WP 0019-00.

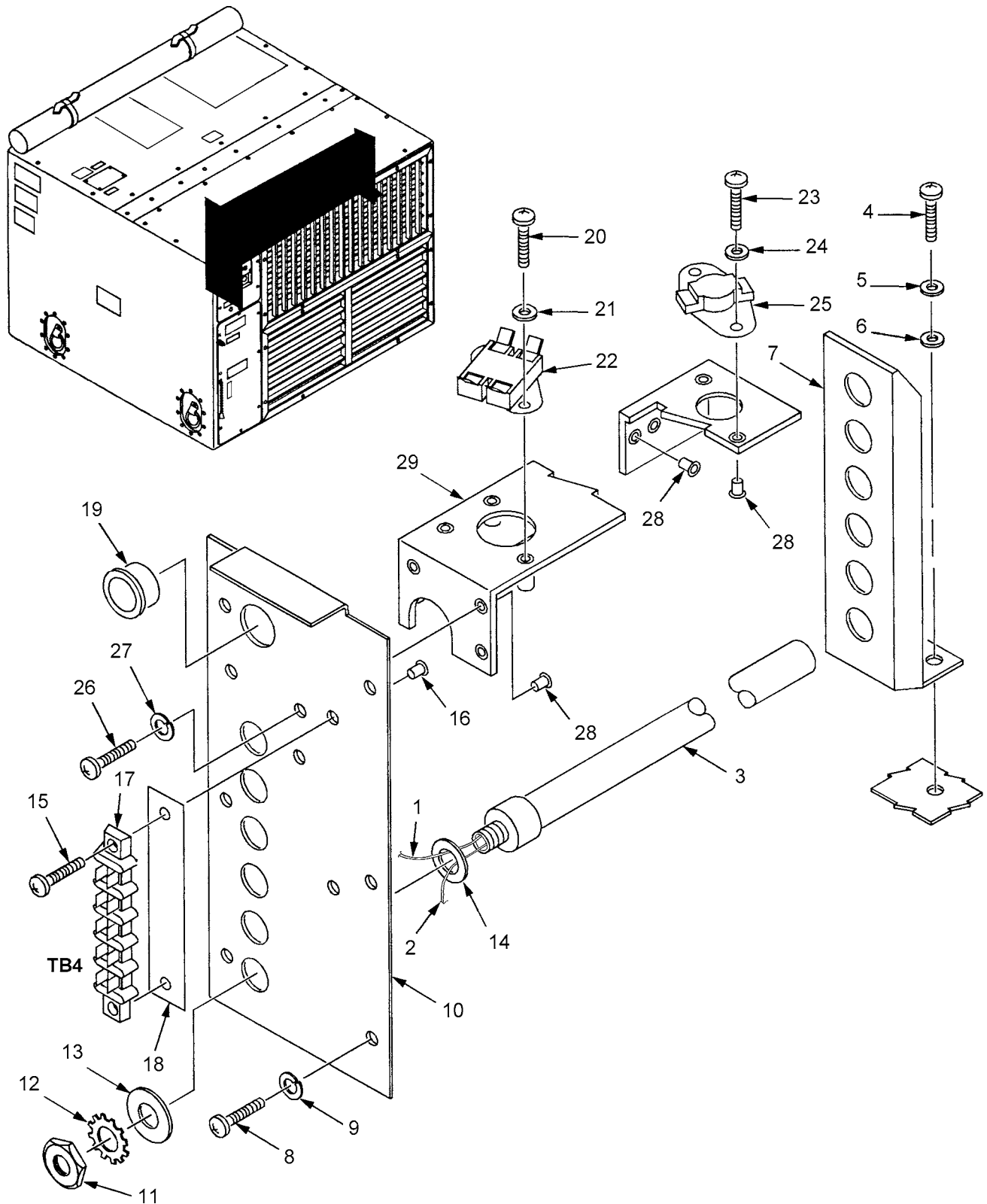

END OF TASK

CONDENSATE DRAIN ASSEMBLY UNIT MAINTENANCE

0029-00

THIS WORK PACKAGE COVERS:Removal, Disassembly, Cleaning, Repair and Installation

INITIAL SETUP:**Maintenance Level**

Unit

Tools and Special Tools

Tool Kit, General Mechanics (Item 1, Table 2, WP 0118-00)

Equipment Condition

Front top cover removed (WP 0019-00).
Evaporator louvers removed (WP 0020-00).
Mist eliminator removed (WP 0026-00).

Materials/Parts

Water, warm soapy
Wire, soft 10-12 gage
Bleach and water solution, mild

WARNING

Disconnect air conditioner power.

REMOVAL AND DISASSEMBLY

1. Loosen four clamps (1), (2), (3), and (4).
2. Remove tubing (5), (6), (7), (8), (9), and (10) from bottom of evaporator drain pan.
3. Remove tee (11) and tee (12).
4. Remove elbow and tee assembly (13).

CLEANING

1. Clean tubing using warm soapy water or replace. Rinse with mild solution of bleach and water. Replace tubing if defective.
2. Clear obstructions from drains at bottom of evaporator compartment using soft wire. Rinse area with bleach solution.
3. Clear obstructions from drain outlet using soft wire. Insert wire from evaporator drain opening.

REPAIR

1. Replace damaged tubing, tee, pipe plug, or hose clamps as necessary.

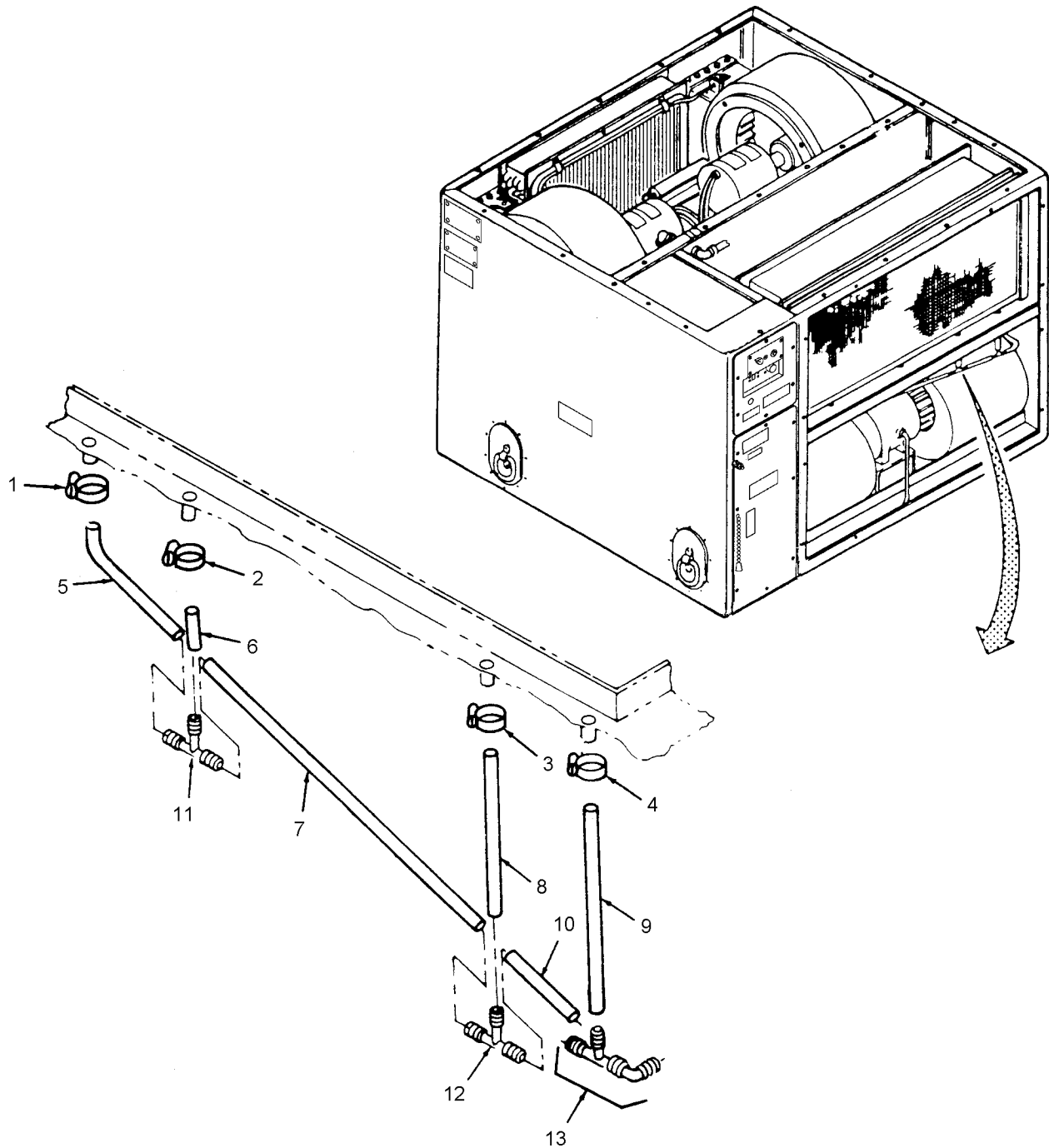

INSTALLATION

1. Install elbow and tee assembly (13).
2. Install tee (12) and (11) to tubing (10), (9), (8), (7), (6), and (5).
3. Tighten clamps (4), (3), (2), and (1).
4. Ensure tubing assembly slopes to outlet drain without trapping condensate.

CONDENSATE DRAIN ASSEMBLY UNIT MAINTENANCE - Continued

0029-00

5. Install mist eliminator. See WP 0026-00.
6. Align and install front top cover. See WP 0019-00.
7. Install evaporator louvers. See WP 0020-00.

END OF TASK

EVAPORATOR FAN MOTOR UNIT MAINTENANCE

0030-00

THIS WORK PACKAGE COVERS:

Test

INITIAL SETUP:

Maintenance Level

Unit Support

Tools and Special Tools

Tool Kit, General Mechanics (Item 1, Table 2, WP 0118-00)

References

Schematic Diagram, WP 0122-00

Equipment Condition

Main power source is disconnected, shut down and cool.

Evaporator air intake louver removed (WP 0020-00).

Junction box assembly partially removed from unit (WP 0035-00).

WARNING

Disconnect air conditioner power.

TEST

1. Carefully slide out junction box assembly from unit to access terminal board TB2 for testing motor B2. Refer to WP 0035-00 and Schematic diagram WP 0122-00.
2. Using an ohmmeter set on lowest ohms scale, check continuity between black lead and red lead (TB2 terminals 10 & 11) of motor B2. Continuity should be indicated between these leads.
3. Test continuity between black lead and green lead (ground) of motor B2 (TB2 terminals 10 and ground). Continuity should NOT be indicated between these leads.
4. Rotate motor shaft very slowly and check for smooth and quiet operation of shaft. Shaft should rotate smoothly and should not make grinding or binding noises.
5. If evaporator motor fails any of the above tests, motor must be replaced. Report motor failure to Direct Support Maintenance shop for replacement.

END OF TASK

CONDENSER FAN MOTOR UNIT MAINTENANCE

0031-00

THIS WORK PACKAGE COVERS:

Test

INITIAL SETUP:

Maintenance Level

Unit Support

Tools and Special Tools

Tool Kit, General Mechanics (Item 1, Table 2, WP 0118-00)

References

Terminal boards TB1 and TB5, WP 0037-00

Schematic Diagram, WP 0122-00

Equipment Condition

Main power source is disconnected, shut down and cool.

Canvas cover detached (WP 0018-00).

Top covers removed (WP 0019-00).

WARNING

Disconnect air conditioner power.

TEST

1. Remove blue lead and red/yellow lead from terminal board TB5 to test condenser motor B3. Refer to WP 0122-00.
2. Using an ohmmeter set on lowest ohms scale, check continuity between blue lead and red/yellow lead on motor B3. Continuity should be indicated between these leads.
3. Remove and test continuity between blue lead and black/yellow lead on motor B4. Continuity should be indicated between these leads.
4. Test for continuity between blue lead and green lead (ground) on both motors. Continuity should NOT be indicated.
5. Rotate motor shaft very slowly and check for smooth and quiet operation of shaft. Shaft should rotate smoothly and should not make grinding or binding noises.
6. If either condenser motor fails any of the above tests, motor must be replaced. Report motor failure to Direct Support Maintenance shop for replacement.

END OF TASK

LOUVER ACTUATOR CABLES UNIT MAINTENANCE

0032-00

THIS WORK PACKAGE COVERS:

Repair, Removal, Installation and Adjustment

INITIAL SETUP:

Maintenance Level

Unit

Tools and Special Tools

Tool Kit, General Mechanics (Item 1, Table 2, WP 0118-00)

Materials/Parts

None

Equipment Condition

Air conditioner shut down and cool.

Rear top panel and canvas cover removed (WP 0018-00 and WP 0019-00).

WARNING

Disconnect air conditioner power.

REPAIR

Repair of louver actuator cables is limited to replacement of defective or damaged components.

REMOVAL

1. Remove screw (1) and cable clip (2).
2. Remove two screws (3) and two mechanical posts (4) attaching louver actuator cables (5) and (6) to louver actuator (19).
3. Release four nuts (7) from cables (5) and (6).
4. Remove two mechanical posts (8) and screws (9) from ends of louver actuator cables (5) and (6). Release four nuts (10) from cables.
5. Pull cables out of angle (12) on condenser fan scrolls (13) and (14).
6. Remove two nuts (10) from angle (15).
7. Pull cables through control bracket (11) and angle (15), and remove cables.
8. Remove four screws (16), four lock washers (17), bracket (18), and control bracket (11).
9. Rivnuts (20) remain in place unless damaged.

INSTALLATION

1. Install control bracket (11), bracket (18), four lock washers (17), and four screws (16).
2. Loosely install cable (5) into angle (15) with nuts (10) and thru plastic tube to angle (12) on condenser fan scroll (13).
3. Loosely install inner set of nuts (10) onto louver actuator cables (5) and (6).
4. Insert end of cables through angles (12) on condenser fan scrolls (13) and (14). Loosely install outer set of nuts (10).
5. Loosely install two mechanical posts (8) and screws (9) onto ends of louver actuator cables (5) and (6).
6. Loosely install inner set of nuts (7) and insert plain cable end through control bracket (11) and into bracket on louver actuator (19). Loosely install outer set of nuts (7).
7. Loosely install two mechanical posts (4) and screws (3) onto ends of louver actuator cables (5) and (6).
8. Loosely install cable clip (2) and screw (1) to hold louver actuator cables (5) and (6).

ADJUSTMENTCAUTION

The louver actuator cables must be adjusted when air conditioner is shut down and cool. If cables are adjusted while unit is not completely cool, cables may be damaged and improper operation of air conditioner may occur.

1. Position the blades of both louver assemblies to a fully closed position.
2. Tighten and position nuts (10) together until both nuts are seated hard against the angle (12) on the condenser fan scrolls (13) and (14).

NOTE

The cable's outer sheath should project one inch from angle (12).

3. Loosen nuts (7) at control bracket (11) to allow louver actuator cables (5) and (6) to be easily moved into the bracket on the louver actuator cylinder (19).

NOTE

The cable's outer sheath should project approximately one inch for cable (5) and approximately one-half inch for cable (6).

4. Install the mechanical posts (4) into louver actuator. Insert cable wires into posts (4) and tighten screws (3).
5. Tighten and position four nuts (7) on louver actuator cables (5) and (6) until each nut is seated hard against control bracket (11).
6. Install the mechanical posts (8) into louver arm (20). Insert cable wires into post (8) and tighten screw (9).
7. Tighten screw (1) to secure louver actuator cable (5) and (6) against the cable mounting bracket (18).

ADJUSTMENT - Continued

8. Position and tighten four nuts (10) on louver actuating cables (5) and (6) until each nut is seated hard against angle (12) on condenser fan scroll.
9. Tighten two nuts (10) hard against angle (15).
10. Install rear top cover and canvas cover. Refer to WP 0018-00 and WP 0019-00.

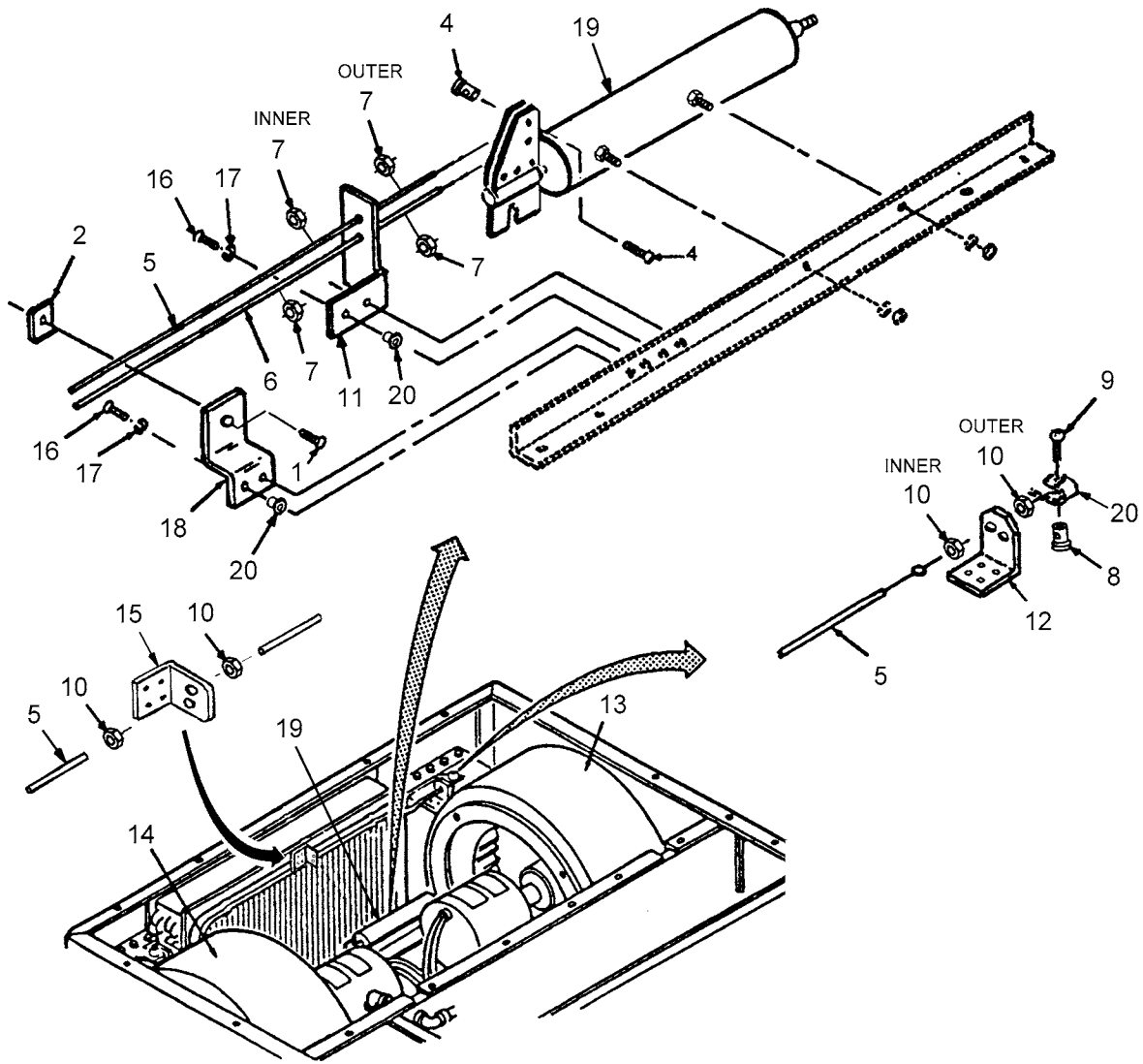

END OF TASK

CIRCUIT BREAKER – UNIT MAINTENANCE

0033-00

THIS WORK PACKAGE COVERS:

Removal, Inspection, Test, Replacement and Assembly

INITIAL SETUP:

Maintenance Level

Unit

Tools and Special Tools

Tool Kit, General Mechanics (Item 1, Table 2, WP 0118-00)
Soldering Gun Kit (Item 9, WP 0118-00, Table 2)
Heat Gun (Item 6, WP 0118-00, Table 2)

Materials/Parts

Solder (Item 2, WP 0121-00)
Flux (Item 15, WP 0121-00)

References

Schematic Diagram, WP 0122-00

Test Equipment

Multimeter

Equipment Condition

Air conditioner shut down and cool.
Power disconnected from unit.
Top covers removed (WP 0019-00).

WARNING

HIGH VOLTAGE

is used in operation of this equipment.

DEATH ON CONTACT

may result if personnel fail to observe safety precautions.

Never work on electrical equipment unless there is another person nearby who is familiar with operation and hazards of equipment and who is competent in administering first aid. When technician is aided by operators, he must warn them about dangerous areas.

Whenever possible, input power supply to equipment must be shut off before beginning work. When working inside, after power has been turned off, always ground every part before touching it. Be careful not to contact high voltage connections when installing or operating this equipment.

Whenever nature of operation permits, keep one hand away from equipment to reduce hazard of current flowing through vital organs of body. Do not operate equipment without all guards, louvers, and covers in place and tightly secured.

WARNING

Disconnect air conditioner power supply.

REMOVAL

1. Disconnect connector P4(15) from connector J4(14) by turning connector P4 counterclockwise.
2. Remove four screws (3), and four lockwashers (4) to remove circuit breaker housing (22) from circuit breaker panel (35).
3. Remove two screws (5) to remove cover (6).

INSPECTION**Circuit Breaker (21)**

1. Inspect toggle for chips, creaks, or damage. Replace circuit breaker if found.
2. Inspect wiring for breaks or damage. Replace if found.
3. Inspect for distinct click and engagement of circuit breaker when placed in ON position. Replace if not found.
4. Inspect for smooth motion to OFF position. Replace if not found

Connectors J2, J3, J4, and P4 (30), (34), (14) and (15)

1. Inspect wiring for breaks, fraying, discoloration, or damage. Replace if found.
2. Inspect soldered connections for breaks or damage. Repair or replace if found.
3. Inspect pins for bending or corrosion. Straighten bent pins if possible. Clean minor corrosion. Replace if necessary.
4. Inspect electrical contacts for corrosion. Replace or clean as necessary.

TEST**Circuit Breaker (21)**

1. Tag and disconnect leads.
2. Check for continuity in ON position between contacts A1 and B1; A2 and B2; A3 and B3. Continuity should exist. No continuity should exist between these contacts in the OFF position.
3. Replace if fails test.

TEST - Continued**Wiring and Connectors**

1. Leave soldered connections secure.
2. Check for continuity by touching the test probes of a multimeter set on low-resistance range, to the ends of wire and/or the corresponding pin of connector. See WP 0122-00, schematic diagram.
3. Replace pins and wire if not found.

REPLACEMENT**Circuit Breaker (21)**

1. Tag and disconnect leads from the circuit breaker. These are terminal lugs. Leave soldered connections secure to connector.
2. Remove pin and middle section of throw switch.
3. Remove six screws (19) and six flat washers (20) securing switch to circuit breaker housing (22).
4. Slide switch (21) through back of housing and remove and replace.

NOTE

Perform removal of connectors only if assured that they are damaged and need replacement.

Connector J4(14)

1. Remove circuit breaker (21).
2. Remove screws (8) and (16), lockwasher (17) and nut (18) to remove bracket (9).
3. Remove four screws (12) and four nuts (13) to release connector J4(14) from bracket (9).
4. Tag wires from connector.
5. Desolder wires from connector pins and replace connector.

Connector J2(30)

1. Remove three screws (28), one screw (24) and nuts (25) and (29) to remove connector (J2) 30 and cover (26).
2. Tag wires, desolder and replace connector.

Connector J3(31)

1. Remove two screws (31), two lockwashers (32) and two nuts (33) to remove connector J3(34).
2. Tag wires, desolder and replace connector.

ASSEMBLY**Circuit Breaker**

1. Connect leads to circuit breaker (21). Remove tags. Ensure ground lead is connected with screw (16), washer (17) and nut (18).
2. Place circuit breaker (21) into housing (22) and align mounting holes.
3. Secure circuit breaker (21) with six screws (19) and six flat washers (20).
4. Assemble pin and middle section of throw switch (21).
5. If removed, reassemble bracket (9) with screws (8).
6. Assemble cover (6) with two screws (5).
7. Assemble circuit breaker housing (22) to circuit breaker panel (35) with four screws (3) and four lock washers (4).
8. Reconnect connector P4(15) to connector J4(14) by turning connector P4 clockwise.
9. Install top covers. See WP 0019-00.

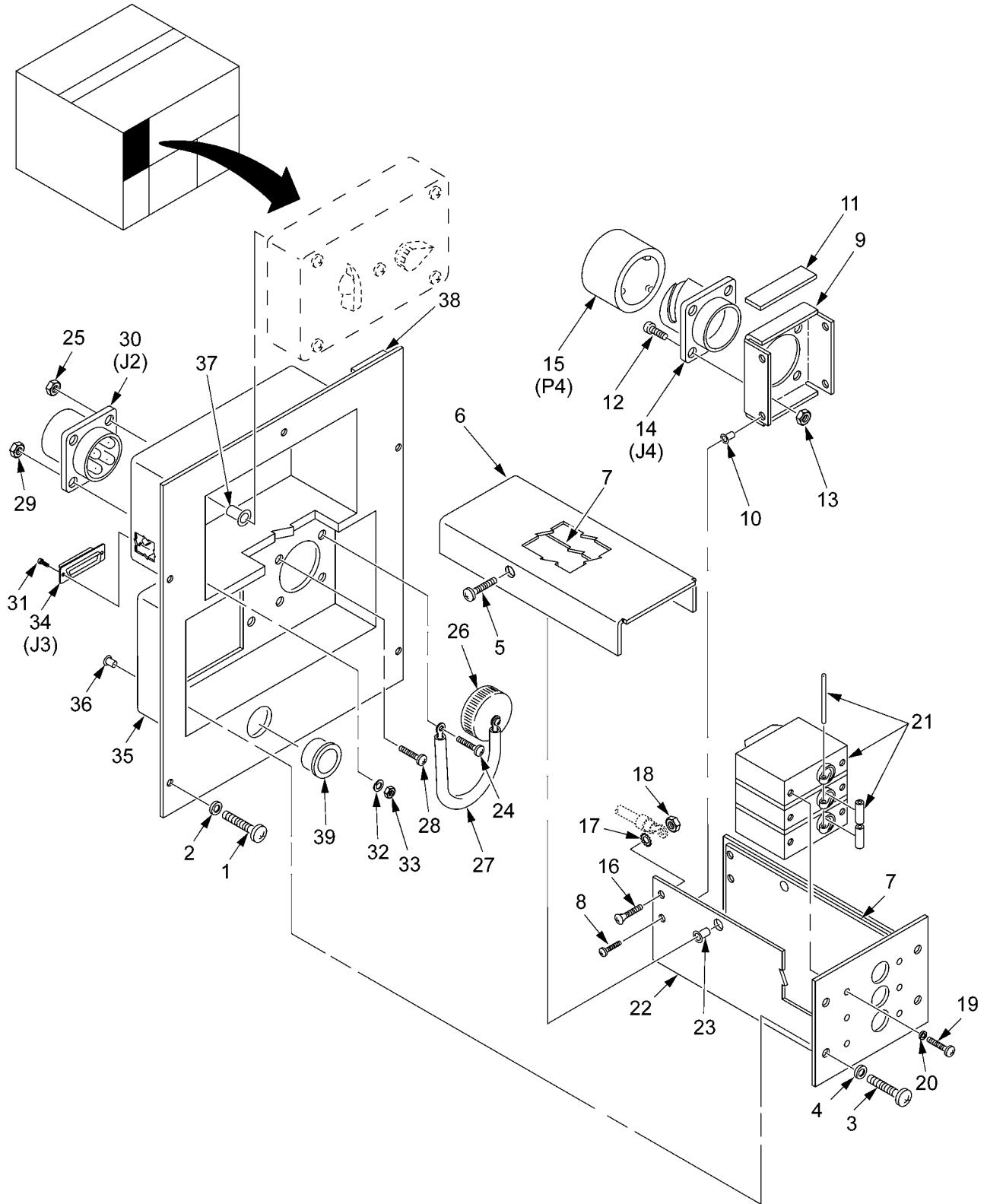

END OF TASK

REMOTE CONTROL MODULE UNIT MAINTENANCE

0034-00

THIS WORK PACKAGE COVERS:

Removal, Inspection, Test, Disassembly, Repair, Assembly and Installation

INITIAL SETUP:

Maintenance Level

Unit

Tools and Special Tools

Tool Kit, General Mechanics (Item 1, WP 0118-00)

Materials/Parts

Solder (Item 2, WP 0121-00)

Flux (Item 15, WP 0121-00)

Test Equipment

Multimeter

References

Schematic Diagram, WP 0122-00

Equipment Condition

Air conditioner shut down and cool.

Power disconnected from unit.

Top covers removed (WP 0019-00).

WARNING

Disconnect air conditioner power supply.

REMOVAL**Control Module**

1. Loosen connector post screw counterclockwise until remote control module is freed from unit. See Figure 1.

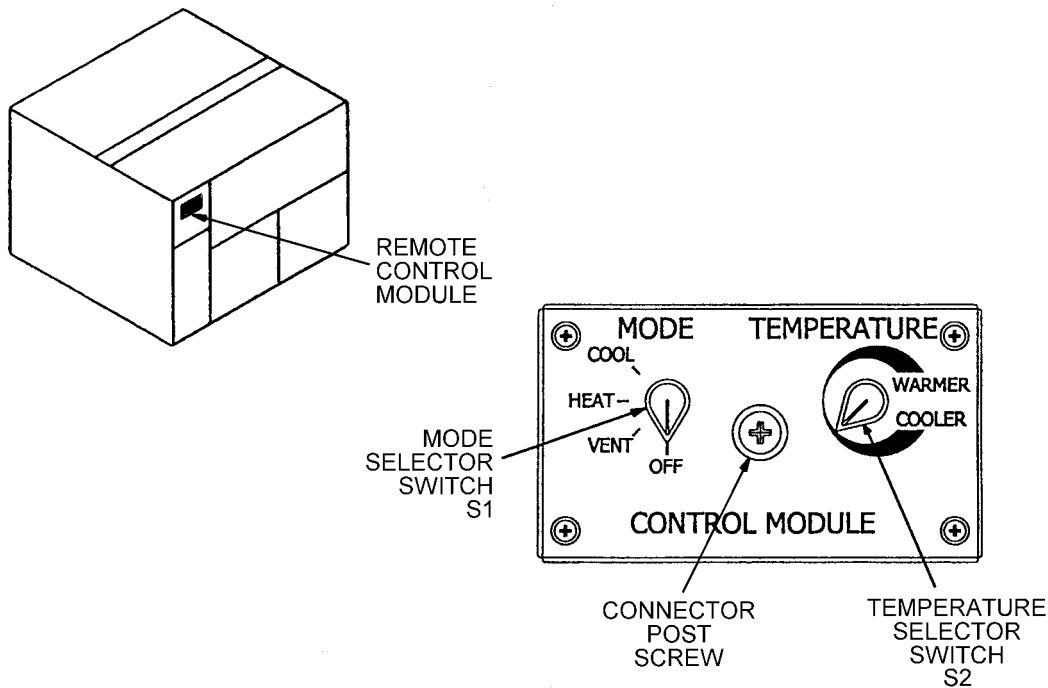

Figure 1. Control Module - Front Panel

2. Carefully pull remote control module straight out of unit to disconnect connector P3 from J3 in rear of remote control module. See schematic diagram WP 0122-00.

INSPECTION**Temperature Selector Switch S2(15) (Refer to Exploded View Figure 3)**

1. Turn temperature control knob (4) from stop-to-stop to ensure smooth operation. Replace if binding occurs.
2. Inspect temperature control knob (4) for chips, cracks, or if indicator line cannot be readily seen. Replace if found defective.

Mode Selector Switch S1(12) (Refer to Exploded View Figure 3)

1. Inspect selector knob (3) for chips, stripping out, cracks, or damage. Replace if found defective.
2. Inspect for distinct click when changing positions. Replace switch if not found.

TEST**NOTE**

Test of temperature selector switch (S2) and mode selector switch S1 can be performed prior to disassembly by using connector P3 pin contacts as test points. Refer to WP 0122-00 schematic diagram and figure 2.

Temperature Selector Switch S2(15) (Refer to Exploded View Figure 3)

1. Turn mode selector switch S1(10) to OFF position.
2. Check for continuity using a multimeter on the lowest ohm setting. Place probes on the connector pins 1 and 12 of connector P3. Continuity should be indicated.
3. Turn switch to COOLER (fully counterclockwise). No continuity should exist.

NOTE

Switch operates in temperature range of 90°F to 60°F (32.2°C to 15.5°C).

4. Turn switch to WARMER (fully clockwise). Meter should show continuity as setting becomes higher than bulb temperature.

Mode Selector Switch S1(12) (Refer to Exploded View Figure 3)

1. Ensure temperature selector switch (S2) (15) is in WARMER position.
2. Check continuity of mode selector switch S1 as follows:
 - a) Switch in OFF position – no continuity should be indicated between connector pins 3 and 7; 5 and 8; or 6 and 1.
 - b) Switch in VENT position – continuity should be indicated between connector pins 3 and 7.
 - c) Switch in HEAT position – continuity should be indicated between connector pins 5 and 8.
 - d) Switch in COOL position – continuity should be indicated between connector pins 6 and 1.
3. Replace if switch fails test.

TEST – Continued

MODE SELECTOR SWITCH				
POSITION	FUNCTION	SWITCH SECTION AND TERMINALS CONNECTED		
		S1A	S1B	S1C
1	OFF	-----	-----	-----
2	VENT	A AND B	-----	-----
3	HEAT	A AND B	E AND D	-----
4	COOL	A AND B	-----	C AND F

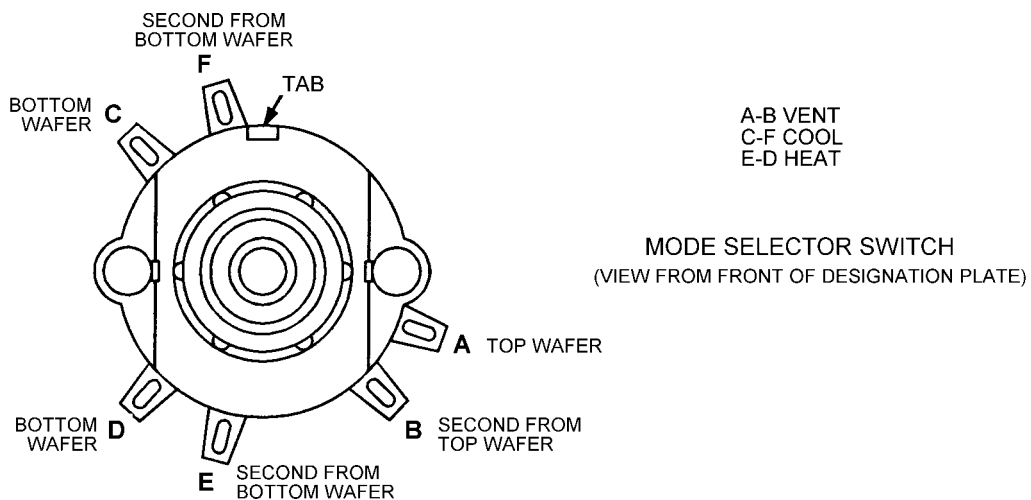

Figure 2. Mode Selector Switch

DISASSEMBLY (Refer to Exploded View Figure 3)

NOTE

Disassembly should be limited to the replacement of defective parts.

1. Loosen setscrew on knob (3) and remove knob from mode selector switch (12).
2. Loosen setscrew on knob (4) and remove knob from potentiometer (15).
3. Remove four screws (5), four flat washers (7), and four lock washers (6), to open control box (9) and control panel (8). Be careful of the wiring.
4. Remove mode selector switch (12) and potentiometer (15) from control panel (8) by removing nuts (10) and (13) and lockwashers (11) and (14).
5. If to be replaced after inspection and test, tag and disconnect wires (22) from defective mode selector switch (12) and potentiometer (15).

DISASSEMBLY (Refer to Exploded View Figure 3) - Continued

6. Remove two nuts (19), two flat washers (18), two lock washers (17) and two screws (16), and connector P3 (21) from control box (9).
7. Remove nut (27) to release ground wire. Remove wire ties (24) as required.
8. Leave insulation (30) and flexible tubing (23) and (31) in place unless damaged, if damaged replace.
9. Leave stop nut (28) and lockwasher (29) in place unless defective, if defective replace.

REPAIR**Control Panel**

1. Remove dents or deformation, if minor. Replace if major.
2. Replace if marking is illegible.
3. Replace damaged insulation (30).

Connector with Leads (20)

1. Inspect wiring for breaks, fraying, discoloration, or damage. Replace if found.
2. Inspect soldered connections for breaks or damage. Repair or replace if found.
3. Inspect pins for bending or corrosion. Straighten bent pins if possible. Clean minor corrosion. Replace if necessary.
4. Inspect electrical contacts for corrosion. Replace or clean as necessary.
5. Tag leads if disassembly is required.
6. Check for continuity by touching the test probes of a multimeter set on low-resistance range, to the ends of wire and/or the corresponding pin of connector. See WP 0122-00, schematic diagram.
7. Replace pins and wire if continuity is not indicated.

ASSEMBLY

1. Attach connector P3(21) to control box (9) and install two screws (16), two flat washers (18), two lock washers (17), and two nuts (19).
2. Install temperature selector switch (15) and mode selector switch (12) into control panel (8) with lock washers (11) and (14).
3. Refer to tags installed during removal and reconnect all wires to mode selector switch (12) and temperature selector switch (15), and then remove tags.
4. Reconnect ground wire with screw (25), washer (26) and nut (27).
5. Install screw (2), lock washer (29), and nut (28) into control panel (8), if removed.
6. Install control panel (8), with four lock washers (6), four flat washers (7), and four screws (5).

ASSEMBLY – Continued

7. Install knob (4) with set screw onto temperature selector switch (15).
8. Install knob (3) with set screw onto mode selector switch (12).

INSTALLATION

1. Place remote control module (1) into opening in front of unit.
2. Ensure connector P3(21) on back of remote control module is mated securely to connector J3 on circuit breaker panel. See schematic diagram WP 0122-00.
3. Secure remote control module (1) with screw (2) by turning screw clockwise.
4. Install front cover (WP 0019-00).
5. Reconnect air conditioner to power source.

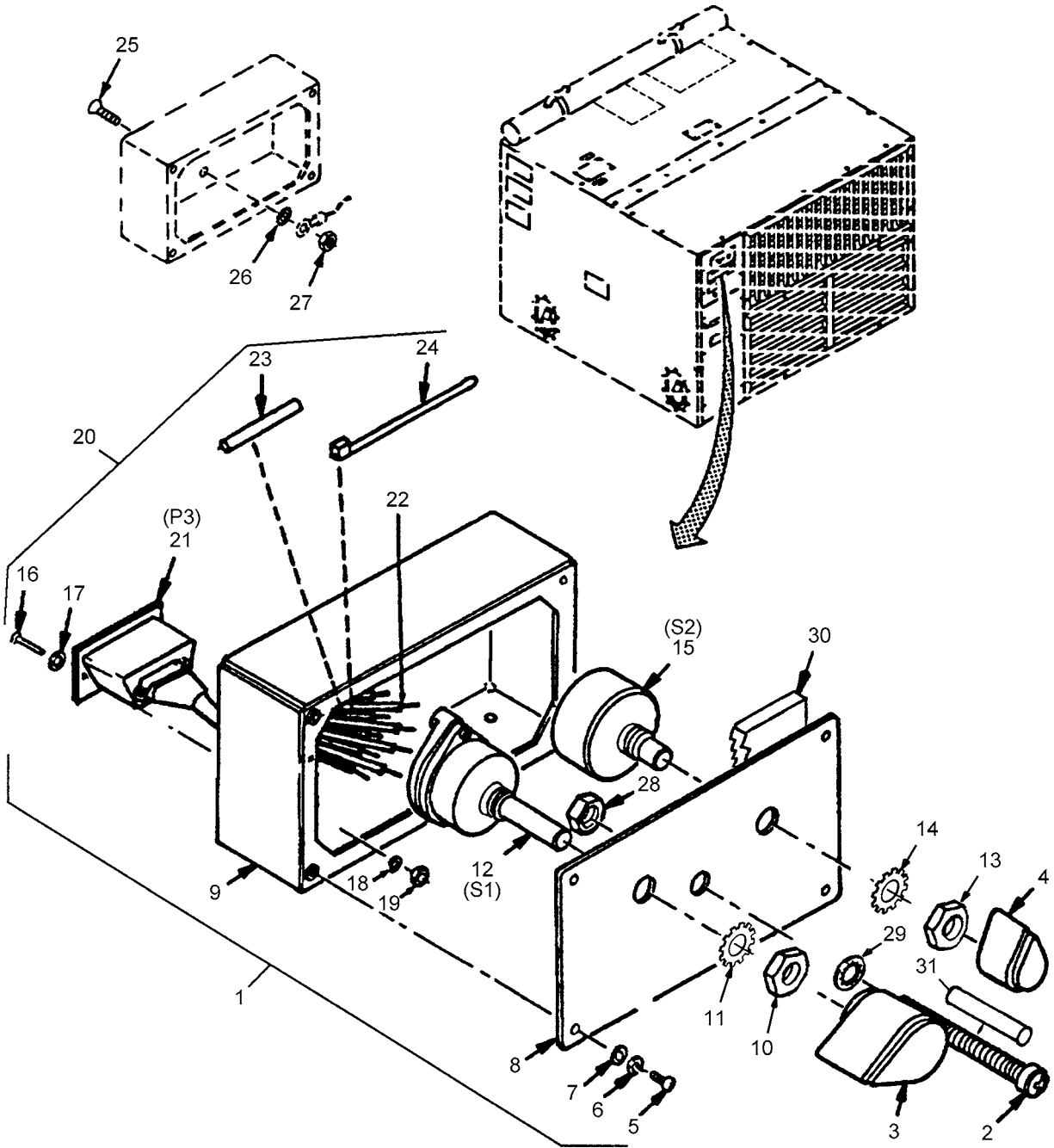

Figure 3. Remote Control Module – Exploded View

END OF TASK

JUNCTION BOX ASSEMBLY – UNIT MAINTENANCE

0035-00

THIS WORK PACKAGE COVERS:

Removal, Inspection, Test, Repair, and Replacement

INITIAL SETUP:

Maintenance Level

Unit

Tools and Special Tools

Tool Kit, General Mechanics (Item 1, WP 0118-00)

Materials/Parts

Solder (Item 2, WP 0121-00)

Flux (Item 15, WP 0121-00)

References

Schematic Diagram (WP 0122-00)

Test Equipment

Multimeter

Variable voltage power source (AC/DC)

Equipment Condition

Air conditioner shut down and cool.

Power disconnected from unit.

Evaporator air intake louver removed (WP 0020-00).

Top covers removed (WP 0019-00).

WARNING

HIGH VOLTAGE

is used in operation of this equipment.

DEATH ON CONTACT

may result if personnel fail to observe safety precautions.

Never work on electrical equipment unless there is another person nearby who is familiar with operation and hazards of equipment and who is competent in administering first aid. When technician is aided by operators, he must warn them about dangerous areas.

Whenever possible, input power supply to equipment must be shut off before beginning work. When working inside, after power has been turned off, always ground every part before touching it. Be careful not to contact high voltage connections when installing or operating this equipment.

Whenever nature of operation permits, keep one hand away from equipment to reduce hazard of current flowing through vital organs of body. Do not operate equipment without all guards, louvers, and covers in place and tightly secured.

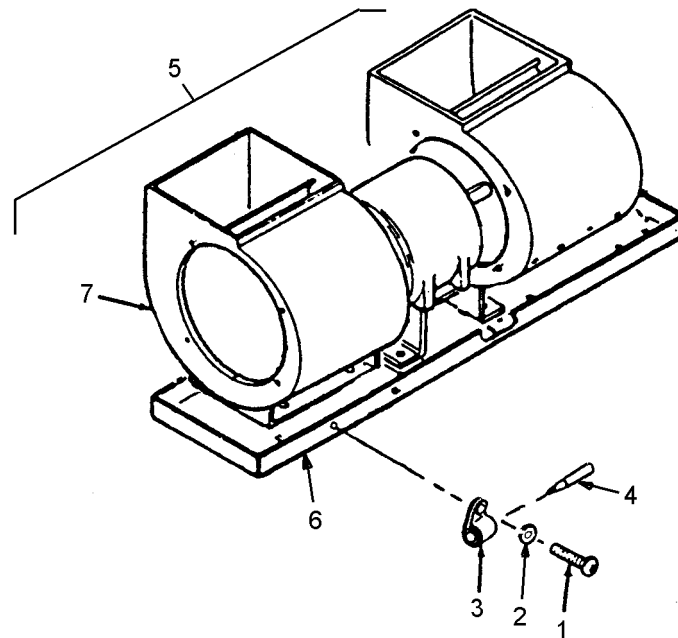

Figure 1

WARNING

Disconnect air conditioner power supply.

REMOVAL AND INSPECTION

Temperature Selector Switch Electronic Probe (Figure 1)

1. Loosen screw (1) and washers (2) to release electronic probe (4) from clamp (3) on evaporator fan assembly (5) located under left scroll (7).
2. Carefully slide out probe from clamp.

Junction Box (Figure 2)

1. Inspect junction box for damage.
2. Inspect all designation plates and instruction plates for damage and illegibility on front panel of junction box.
3. Replace damaged designation markings, instruction plates and designation plates. See WP 0025-00.
4. Remove eight screws (8) and eight lockwashers (9) that secure the junction box to the unit housing
5. Partially remove the junction box by pulling it forward and out of the air conditioner. Care must be taken with the wiring.
6. Support the junction box to relieve strain on wiring.

REMOVAL AND INSPECTION - Continued**Junction Box-Continued****NOTE**

It is not necessary to remove junction box completely from unit. Most repairs and replacements can be made without removing junction box completely. Junction box can be moved out approximately 18 inches from the unit.

7. Remove cover (15) by removing four screws (14).
8. Inspect wiring for cracked or frayed insulation and loose connections.
9. Replace junction box if damaged enough to prevent normal operation of air conditioner.

Compressor Motor and Condenser Motors Relay (K1), Heaters Relay (K2), Evaporator Fan Motor Relay (K3), Time Delay Device (TD)

1. Inspect relays (20) for any external damage to housing.
2. If damaged enough to prevent normal operation of relay, replace relay.

Terminal Boards (26 and 30) and Marker Strips (27 and 29)

1. Inspect terminal boards for dents, breaks, nicks or damaged terminals.
2. If unrepairable, replace terminal board.
3. Inspect marker strips for illegibility or damage.
4. Replace marker strip if damaged.

Unit Ground Stud (41) (Figure 3)

Inspect unit ground stud for damage, corrosion or missing parts. Replace as necessary.

TEST**Compressor Control Time Delay Device (TD) (24)**

1. Tag and disconnect wire leads from all terminals.
2. Using a known functional relay, such as K1, connect the relay coil A terminal to time delay device terminal No.1.
3. Apply a 24 ± 5 V ac power source to terminal No.2 on time delay device and B terminal on relay. Test relay should “pull-in” in approximately 60 ± 20 seconds.
4. Replace if it fails test.

TEST – Continued**Compressor Motor and Condenser Motors Relay (K1), Heaters Relay (K2), Evaporator Fan Motor Relay (K3)**

1. Tag and disconnect wire leads.
2. Use a multimeter. Set on the lowest ohm to check continuity between terminals L1 to T1, L2 to T2 and L3 to T3. All contacts should be open. If there is continuity, replace the relay. See WP 0122-00.
3. Check continuity between terminals A and B. If there is no continuity, the coil is open. Replace the relay.
4. Apply 24 V ac across terminals A and B and repeat continuity checks between terminals L1 to T1, L2 to T2 and L3 to T3. All three contacts should be closed. If there is no continuity, replace the relay.

Thermostat (13)

1. Remove and tag thermostat (13) wire from terminal board TB3-8.
2. Apply a 24 ± 5 V ac power source to the thermostat wire removed from TB3-8 and to terminal board TB3-2.
3. With temperature selector switch (S2) in “COOLER” position (full counterclock) and mode selector switch (S1) in “COOL” position, warm the thermostat probe (4) by holding in hand.
4. Check voltage (24 V ac) between terminal board TB3-2 and TB3-7.
5. Replace if NO voltage.
6. With temperature selector switch (S2) in “WARMER” position (full clockwise) and mode selector switch (S1) in “HEAT” position cool the thermostat probe (4) in ice bath.
7. Check voltage (24 V ac) between terminal board TB3-2 and TB3-3.
8. Replace if NO voltage.

REPAIR**Junction Box**

Repair or straighten sheet metal parts.

REPLACEMENT**NOTE**

Ensure wire leads are tagged before disconnecting.

Compressor Motor and Condenser Motors Relay (K1)(20), Heaters Relay (K2)(20), Evaporator and Condenser Motor Relay (K3)(20)

1. Remove the relays (K1-K3) (20) from the junction box by removing four screws (19) from each relay.
2. Install replacement relays (K1-K3) on the junction box chassis (36).
3. Secure each relay (20) to junction box chassis (36) with four screws (19).

REPLACEMENT - Continued**Compressor Time Delay Device (TD) (24)**

1. Remove time delay device (TD)(24) from junction box chassis (36) by removing screw (21) flat washer (23) and lock washer (22).
2. Install replacement time delay device (TD)(24) on chassis (36). Position as shown on exploded view.
3. Secure time delay device to junction box with screw, washers and nut removed in step 1 above.

Terminal Board (TB3) (26) and Marker Strip (27)

1. Remove two screws (25).
2. Remove terminal board (TB3)(26) and marker strip (27) from chassis (36).
3. Install replacement terminal board (TB3)(26) and marker strip (27) on chassis (36).
4. Secure to chassis using two screws (25).

Terminal Board (TB2) (30) and Marker Strip (29)

1. Remove two screws (28).
2. Remove terminal board (TB2)(30) and marker strip (29) from chassis (36).
3. Install replacement terminal board (TB2)(30) and marker strip (29) on chassis (36).
4. Secure to chassis using two screws (28).

Thermostat (13)

1. After removing cover (15), remove strap (11) and thermostat (13) by removing two screws (10).
2. Remove defective thermostat and wiring along with connector J3 and probe.
3. Install replacement probe (4) to evaporator fan chassis (6) with clamp (3), screw (1) and flat washer (2).
4. Install wiring and connector J3.
5. Install strap and thermostat to cover (15) with two screws (10).
6. Ensure all wire connections and grounds are correct and secure. See schematic diagram WP 0122-00. Remove tags.
7. Install cover (15) to chassis (36) with four screws (14).

Transformer (18)

See WP 0036-00 for maintenance instructions.

REPLACEMENT – Continued

Junction Box

1. Carefully install junction box on to support bracket (39) into the unit housing and secure with eight screws (8) and eight lockwashers (9).
2. Position wiring away from blower inlet scroll (7).
3. Install evaporator air intake louver. See WP 0020-00.
4. Install top covers. See WP 0019-00.

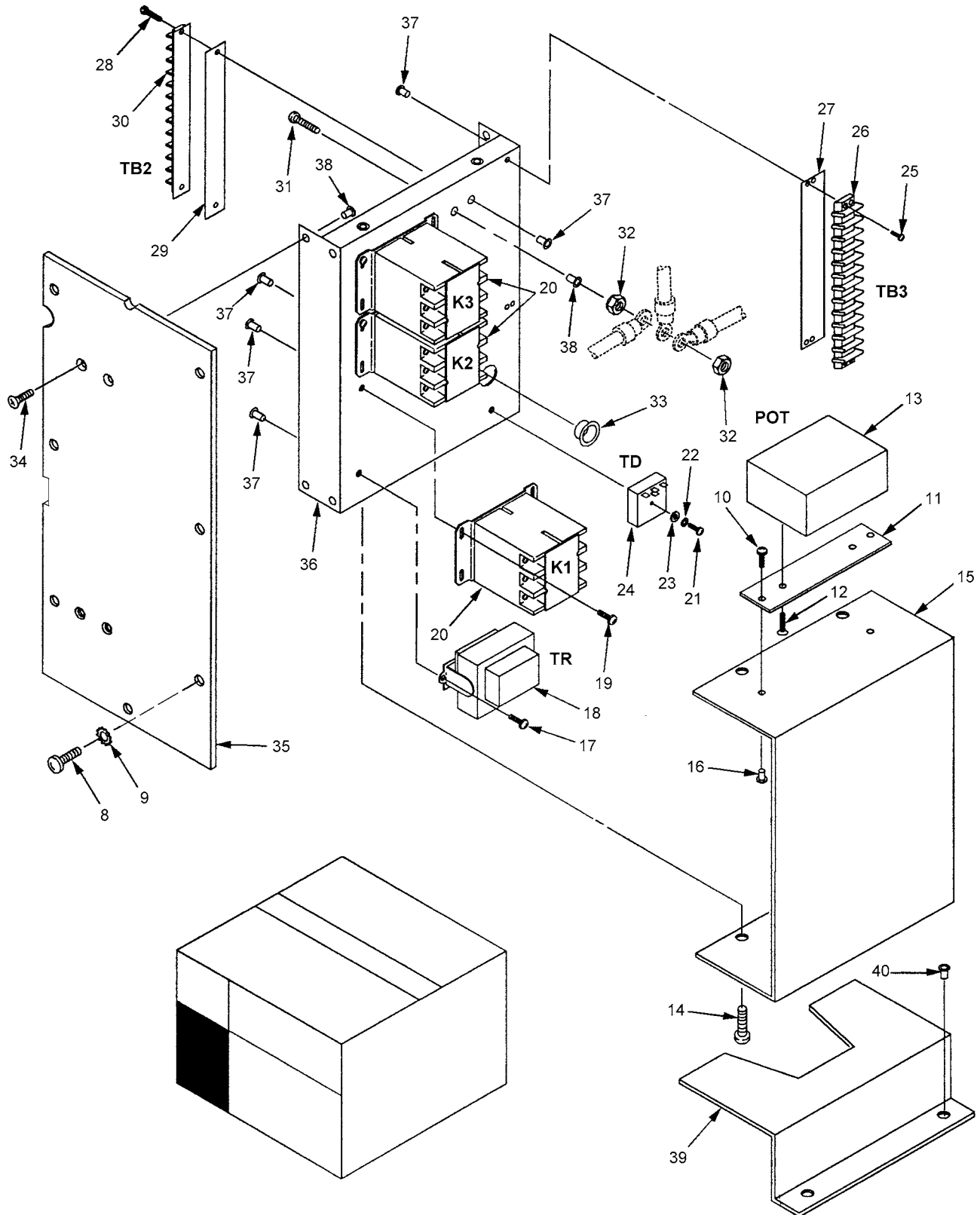

Figure 2

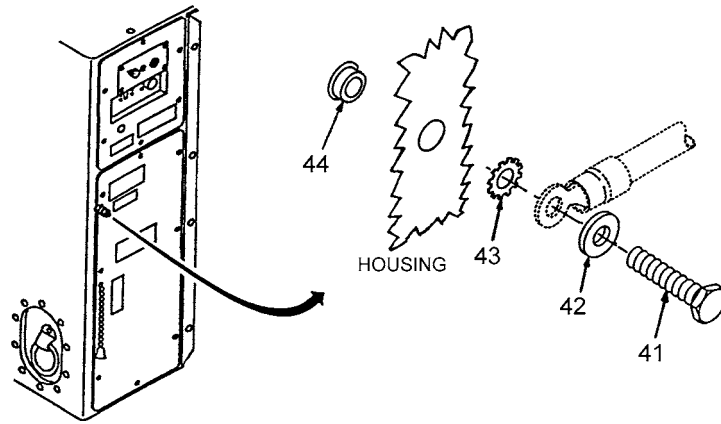

Figure 3

END OF TASK

TRANSFORMER UNIT MAINTENANCE

0036-00

THIS WORK PACKAGE COVERS:

Removal, Test, and Installation.

INITIAL SETUP:

Maintenance Level

Unit

Tools and Special Tools

Tool Kit, General Mechanics (Item 1, WP 0118-00)

Materials/Parts

Solder (Item 2, WP 0121-00)

Flux (Item 15, WP 0121-00)

References

Schematic Diagram, WP 0122-00

Test Equipment:

Multimeter

Variable voltage power source (AC/DC)

Equipment Condition

Air conditioner shut down and cool.

Power disconnected from unit.

Top covers removed (WP 0019-00).

Evaporator air intake louver removed (WP 0020-00)

Junction box partially removed from unit (WP 0035-00)

Junction box chassis cover removed (WP 0035-00).

WARNING

HIGH VOLTAGE

is used in operation of this equipment.

DEATH ON CONTACT

may result if personnel fail to observe safety precautions.

Never work on electrical equipment unless there is another person nearby who is familiar with operation and hazards of equipment and who is competent in administering first aid. When technician is aided by operators, he must warn them about dangerous areas.

Whenever possible, input power supply to equipment must be shut off before beginning work. When working inside, after power has been turned off, always ground every part before touching it. Be careful not to contact high voltage connections when installing or operating this equipment.

Whenever nature of operation permits, keep one hand away from equipment to reduce hazard of current flowing through vital organs of body. Do not operate equipment without all guards, louvers, and covers in place and tightly secured.

WARNING

Disconnect air conditioner power supply.

REMOVAL

1. Remove two screws (1) to remove transformer (2) from junction box chassis (3).
2. Tag and disconnect transformer leads (1/4 in. quick connects).
3. Lift transformer (3) out of unit.

TEST

1. Using a multimeter set on lowest OHMS scale check for continuity across primary terminals "COMN" and "208 V ac". Continuity should be indicated.
2. Using a multimeter set on lowest OHMS scale check for continuity across secondary terminals (24 volts). Continuity should be indicated.
3. Using a multimeter set on lowest OHMS scale check for continuity between primary (208 V ac) and secondary (24 V ac) coils. Multimeter should read NO continuity.
4. If transformer fails steps 1, 2, or 3, transformer is defective. Replace transformer.

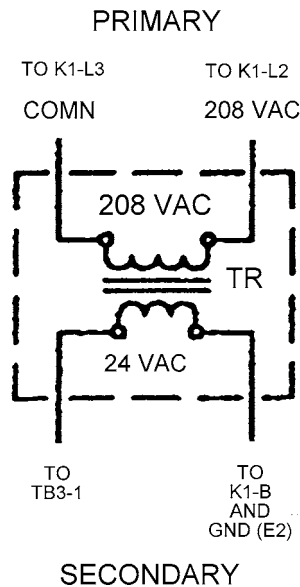

INSTALLATION

1. Connect transformer leads and remove tags.
2. Secure transformer (2) to junction box chassis (3) using two screws (1).
3. Install junction box. See WP 0035-00.
4. Install evaporator air intake louver. See WP 0020-00.
5. Install front top covers. See WP 0019-00.

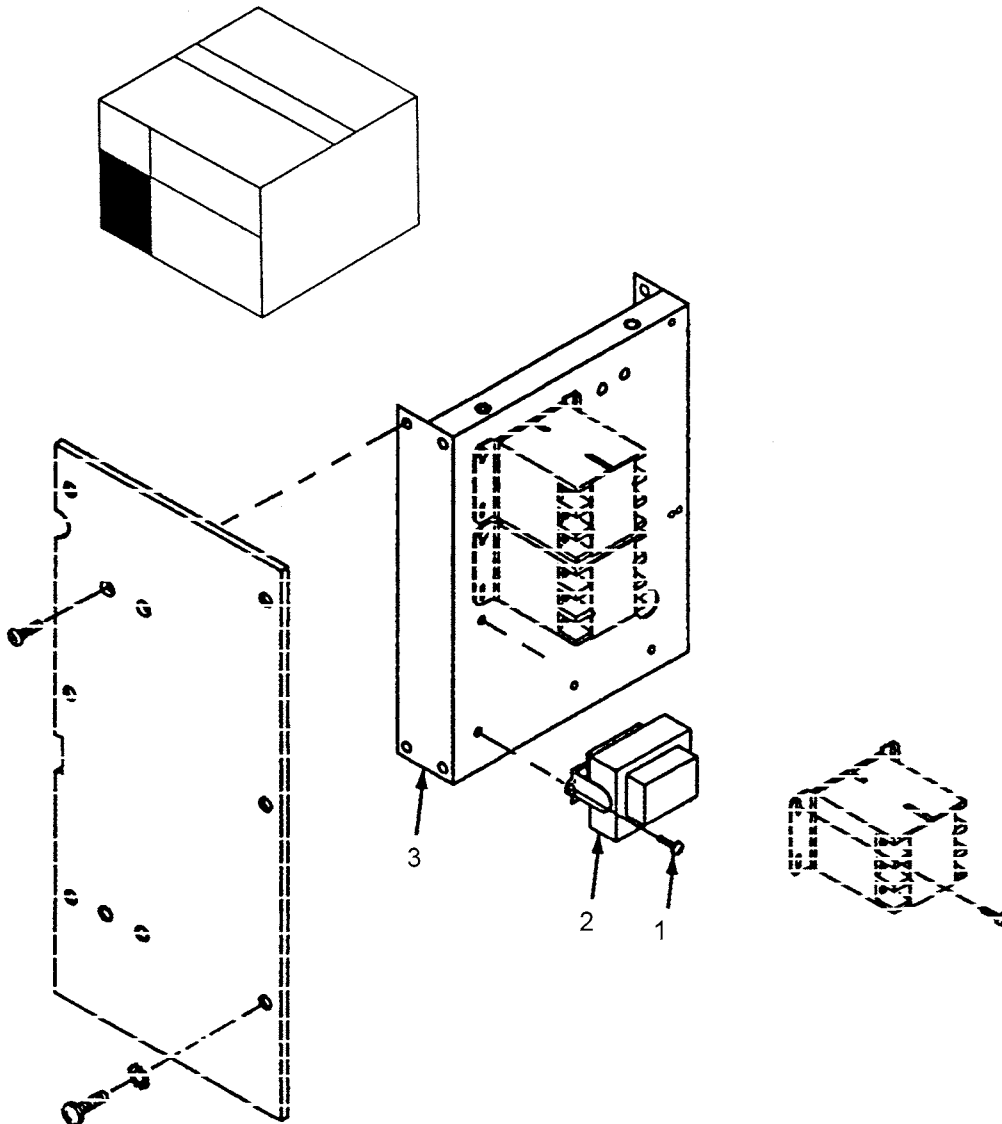
**END OF TASK**

TERMINAL BOARDS TB1 AND TB5 – UNIT MAINTENANCE

0037-00

THIS WORK PACKAGE COVERS:

Inspection, Removal, and Installation

INITIAL SETUP:

Maintenance Level

Unit

Tools and Special Tools

Tool Kit, General Mechanics (Item 1, Table 2, WP 0118-00)
Soldering Gun Kit (Item 9, WP 0118-00, Table 2)
Heat Gun (Item 6, WP 0118-00, Table 2)

Materials/Parts

Solder (Item 2, WP 0121-00)
Flux (Item 15, WP 0121-00)

References

Schematic Diagram, WP 0122-00

Test Equipment

Multimeter

Equipment Condition

Air conditioner shut down and cool.
Power disconnected from unit.
Top covers removed (WP 0019-00).
Control module and junction box partially removed (WP 0034-00 and WP 0035-00).

WARNING

HIGH VOLTAGE

is used in operation of this equipment.

DEATH ON CONTACT

may result if personnel fail to observe safety precautions.

Never work on electrical equipment unless there is another person nearby who is familiar with operation and hazards of equipment and who is competent in administering first aid. When technician is aided by operators, he must warn them about dangerous areas.

Whenever possible, input power supply to equipment must be shut off before beginning work. When working inside, after power has been turned off, always ground every part before touching it. Be careful not to contact high voltage connections when installing or operating this equipment.

Whenever nature of operation permits, keep one hand away from equipment to reduce hazard to current flowing through vital organs of body. Do not operate equipment without all guards, louvers, and covers in place and tightly secured.

WARNING

Disconnect air conditioner power supply.

INSPECTION

1. Inspect all installed wiring for cracked or frayed insulation. Pay particular attention to wires routed around sharp edges.
2. Repair or replace bad wiring.
3. Inspect terminal boards TB1 and TB5 for damage or poor connections.
4. Replace damaged terminal boards.

REMOVAL

1. Tag and disconnect all wires connected to terminal board TB1 (5), and terminal board TB5 (11).
2. Remove four screws (1 and 7), four flat washers (4), four lock washers (3), and four nuts (2) to release terminal board TB1 (5) and two marker strips (6).
3. Remove four screws (8 and 10), four flat washers (4), four lock washers (3), four nuts (2), to release two marker strips (9), and terminal board TB5 (11).

INSTALLATION

1. Install terminal board TB1 (5), and two marker strips (6), with four flat washers (4), four lock washers (3), and four screws (1 and 7).
2. Install terminal board TB5 (11), and two marker strips (9) with four nuts (2), four lockwashers (3), four flat washers (4), and four screws (8 and 10).
3. Refer to wire tags installed during removal and reconnect all wires to terminal boards TB1 (5), TB5 (11) and remove tags.
4. Install control module and junction box (WP 0034-00 and WP 0035-00).
5. Install top covers (see WP 0019-00).
6. Reconnect air conditioner to power source.

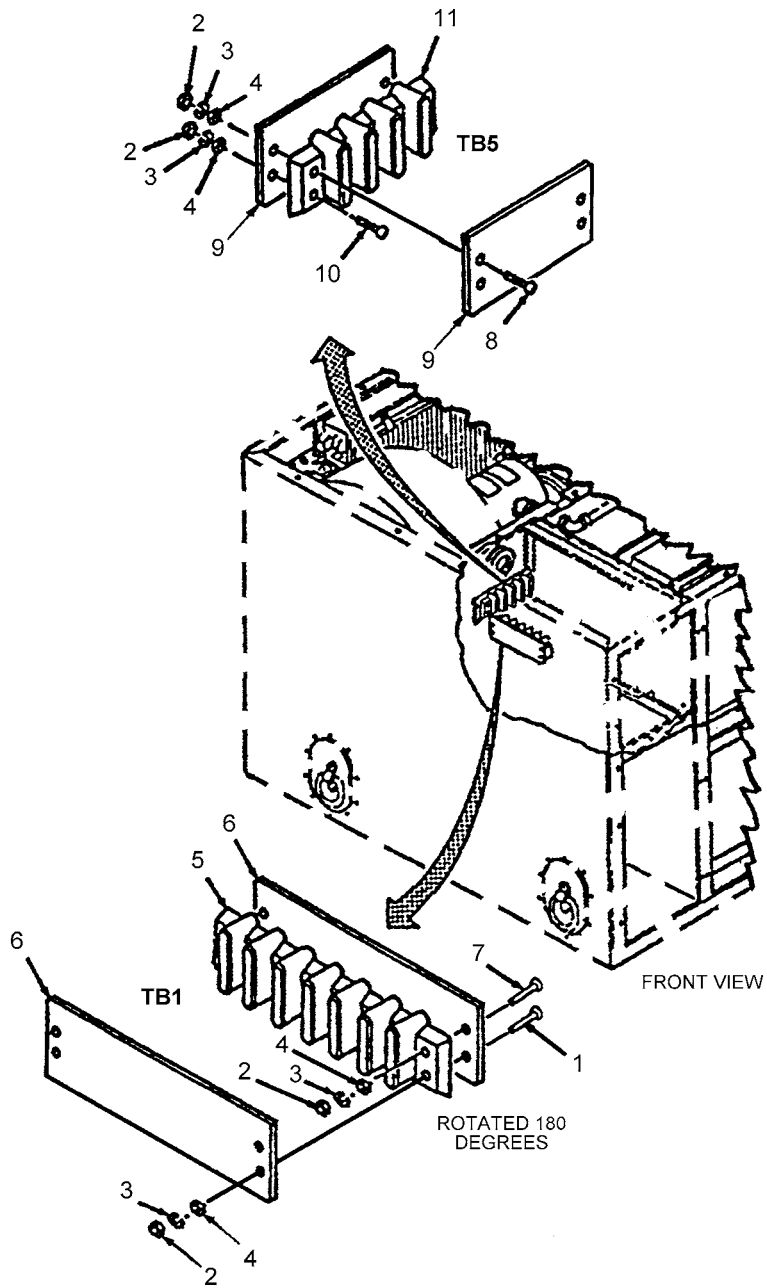

END OF TASK

UNIT WIRING – UNIT MAINTENANCE

0038-00

THIS WORK PACKAGE COVERS:Inspection, Test, Removal, Repair, and Installation

INITIAL SETUP:**Maintenance Level**

Unit

Tools and Special Tools

Tool Kit, General Mechanics (Item 1, Table 2, WP 0118-00)
Soldering Gun Kit (Item 9, WP 0118-00, Table 2)
Heat Gun (Item 6, WP 0118-00, Table 2)

Materials/Parts

Solder (Item 2, WP 0121-00)
Flux (Item 15, WP 0121-00)

References

Schematic Diagram, WP 0122-00

Test Equipment

Multimeter

Equipment Condition

Air conditioner shut down and cool.
Power disconnected from unit.
Top covers removed (WP 0018-00 and WP 0019-00).
Control module and circuit breaker partially removed (WP 0033-00 and WP 0034-00).
Junction box partially removed (WP 0035-00).

WARNING

Disconnect air conditioner power supply.

INSPECTION

1. Inspect all installed wiring for cracked or frayed insulation. Pay particular attention to wires routed around sharp edges.
2. Repair or replace bad wiring.
3. Inspect electrical input power connectors (J2 and J1 ALTERNATE) for damage. Inspect electrical connector J3 and J4 for damage.
4. Replace damaged connectors.

UNIT WIRING – UNIT MAINTENANCE - Continued

0038-00**TEST**

1. Test for continuity on wiring.
2. Touch the test probes of a multimeter set on low-resistance range to ends of wire and/or corresponding pin of connector.
3. If continuity is not indicated, repair or replace wire or damaged connector.

REMOVAL

1. Tag all wire leads prior to removal.
2. Refer to WP 0033-00 for connectors J2, J3, and J4 removal and WP 0043-00 for connector J1 removal.
3. Disconnect all terminals.
4. Carefully remove connectors from unit.

REPAIR

1. Remove the insulation to expose 1/2 inch (1.27 centimeters) of bare wire on each side of break or damaged insulation.
2. Insert the ends into a splice-connector, splice and crimp the connector to make firm electrical contact.
3. Alternatively, heat-shrink tubing may be slipped over one end of the wire before splicing, then heated after the splice is made and soldered, so as to cover the spliced area.
4. Be sure that no bare wire is exposed after splice is complete.
5. Replace broken terminal lugs with exact duplicates.
6. Check continuity terminal-to-terminal.

INSTALLATION

1. Transfer tags to new wires.
2. Install connectors (J1, J2, J3 and J4). Refer to WP 0033-00 and WP 0043-00.
3. Connect all terminals and remove tags. Use schematic diagram (WP 0122-00).
4. Install circuit breaker. See WP 0033-00.
5. Install control module. See WP 0034-00.
6. Install junction box. See WP 0035-00.

END OF TASK

COIL (SOLENOID VALVE)

0039-00

THIS WORK PACKAGE COVERS:

Test, Removal, and Installation

INITIAL SETUP:

Maintenance Level

Unit

Tools and Special Tools

Tool Kit, General Mechanics (Item 1, Table 2, WP 0118-00)

References

Schematic Diagram, WP 0122-00

Test Equipment

Multimeter

Equipment Condition

Air conditioner shut down and cool.

Power disconnected from unit.

Rear top cover removed (WP 0018-00 and WP 0019-00).

WARNING

Disconnect air conditioner power supply.

TEST

1. Using multimeter set on the lowest OHMS scale, check for continuity between leads of coil. If continuity is not found, coil is open and must be replaced.
2. Using multimeter set on lowest OHMS scale, check for continuity between each lead and coil casing. If continuity is found between either lead and the casing, the coil is grounded and must be replaced.

REMOVAL

1. Tag and disconnect wires connected to solenoid valves (1) and (4).
2. Remove spring clips (3) and (6) and coils (2) and (5).

INSTALLATION

1. Install coils (2) and (5), with spring clips (3) and (6) onto solenoid valves (1) and (4).
2. Refer to wire tags installed during removal and reconnect wires of coil as indicated and then remove tags.
3. Install rear top cover. See WP 0018-00 and WP 0019-00.
4. Reconnect air conditioner to power source.

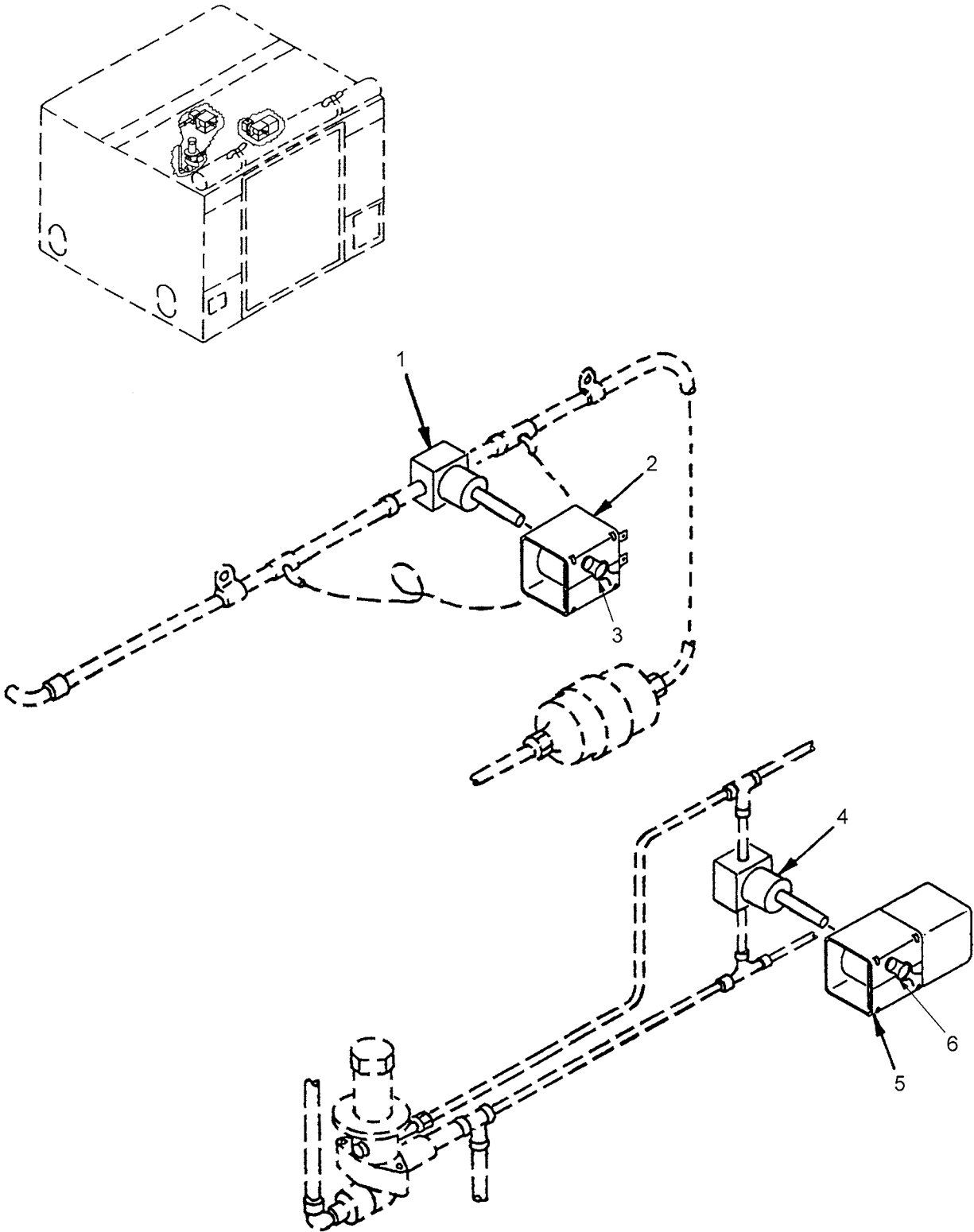

END OF TASK

EVAPORATOR COIL – UNIT SERVICE

0040-00

THIS WORK PACKAGE COVERS:

Inspection and Cleaning

INITIAL SETUP:

Maintenance Level

Unit

Tools and Special Tools

Tool Kit, General Mechanics (Item 1, Table 2, WP 0118-00)

Equipment Condition

Front top cover removed (WP 0019-00).
Evaporator air louvers removed (WP 0020-00).
Mist eliminator removed (WP 0026-00).

WARNING

Disconnect air conditioner power supply.

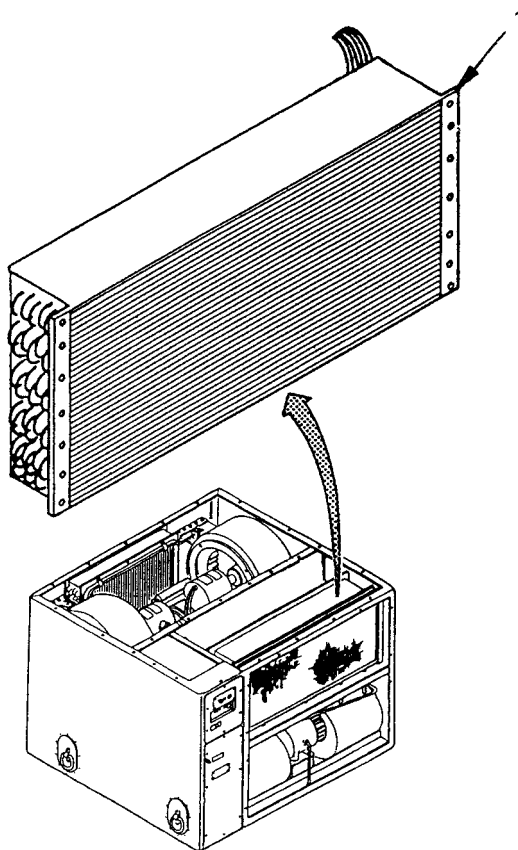

INSPECTION

1. Check to be sure power is disconnected.
2. Check for accumulated dirt. Clean if an accumulation of dirt is evident.
3. Check fins for dents, bent edges, or any condition that would block or distort airflow. Straighten all damaged fins.

WARNING

Compressed air used for cleaning purposes shall not exceed 30 psi (2.1 kg/ cm²).

CAUTION

Do not use steam to clean coil.

CLEANING

NOTE

Evaporator coils encounter extremely dirty and muddy conditions that may require washing with a water hose and/or some chemical cleaner. Several types of foaming spray can coil cleaners that are commercially available may be used.

Clean coil with a soft bristle brush, vacuum cleaner and brush attachment, or use compressed air at 30 psi or less from the inside of the unit to blow the dirt out. Take care to avoid fin damage. When using compressed air, wear safety glasses or goggles. Dirt can be blown into your eyes.

END OF TASK

THIS WORK PACKAGE COVERS:

Inspection and Cleaning

INITIAL SETUP:

Maintenance Level

Unit

Tools and Special Tools

Tool Kit, General Mechanics (Item 1, Table 2, WP 0118-00)

WARNING

Disconnect air conditioner power supply.

INSPECTION

1. Remove eight screws (1) and eight lockwashers (2) and fasteners (3) securing guard (4). Remove guard from unit (5).
2. Check for accumulated dirt. Clean if an accumulation of dirt is evident.
3. Check fins for dents, bent edges, or any condition that would block or distort airflow. Straighten all damaged fins.

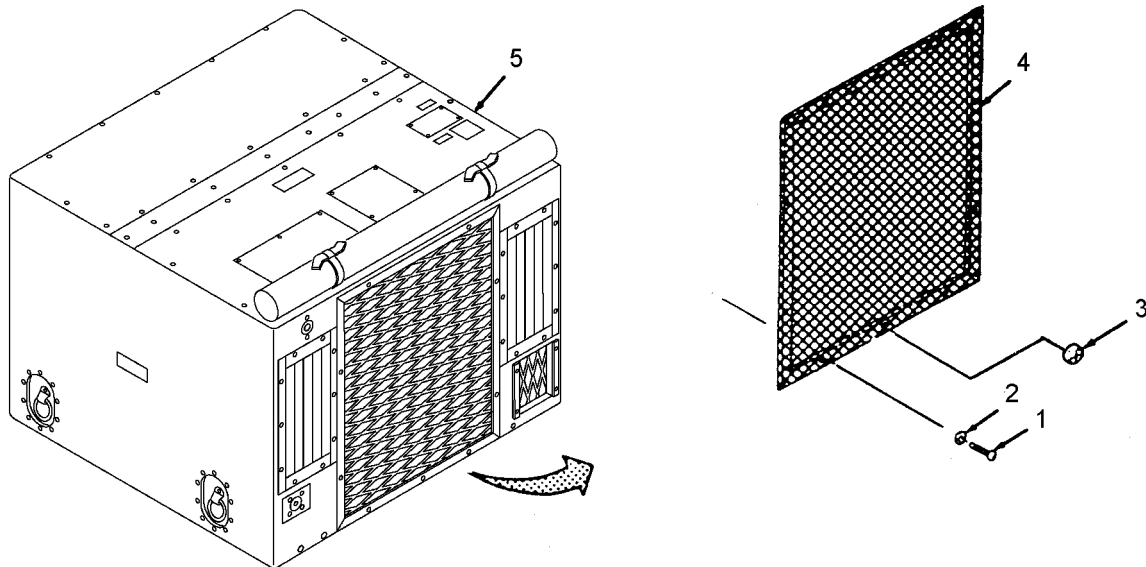

WARNING

Compressed air used for cleaning purposes will not exceed 30 psi (2.1 kg/ cm²).

CAUTION

Do not use steam to clean coil.

CLEANING

NOTE

Condenser coils encounter extremely dirty and muddy conditions that may require washing with a water hose and/or some chemical cleaner. Several types of foaming spray can coil cleaners that are commercially available may be used.

1. Clean coil with a soft bristle brush, vacuum cleaner and brush attachment, or use compressed air at 30 psi or less from the inside of the unit to blow the dirt out. Take care to avoid fin damage. When using compressed air, wear safety glasses or goggles. Dirt can be blown into your eyes.
2. Attach guard (4) and secure with eight screws (1), eight lockwashers (2) and fasteners (3).

END OF TASK

HOUSING UNIT SERVICE

0042-00

THIS WORK PACKAGE COVERS:

Inspection and Service

INITIAL SETUP:

Maintenance Level

Unit

Material/Part:

Dry cleaning solvent (Item 16, WP 0121-00)

Warm soapy water

WARNING

Disconnect air conditioner power supply.

WARNING

Clean parts in well-ventilated area. Avoid inhalation of solvent fumes and prolonged exposure of skin to cleaning solvent. Wash exposed skin thoroughly. Dry cleaning solvent, P-D-680 Type III, which is used to clean parts, is potentially dangerous to personnel and property. Avoid repeated and prolonged skin contact. Do not use near open flame or excessive heat. Flash point of solvent is 100°F to 138°F (38°C to 59°C).

INSPECTION

Visually inspect the housing for cleanliness, nicks, gouges, dents, bare spots in paint or other defects.

SERVICE

1. If cleaning is required, wipe off dirt or grime with a cloth moistened with warm soapy water or dry cleaning solvent (Item 16, WP 0121-00).
2. Report any necessary repairs to general maintenance personnel.

END OF TASK

MAIN POWER INPUT CONNECTOR (J2) and ALTERNATE POWER INPUT CONNECTOR (J1) – UNIT MAINTENANCE

0043-00

THIS WORK PACKAGE COVERS:

Inspection, Removal, Test, Repair, and Installation

INITIAL SETUP:

Maintenance Level

Unit

Tools and Special Tools

Tool Kit, General Mechanics (Item 1, Table 2, WP 0118-00)

Materials/Parts

Solder (Item 2, WP 0121-00)

Flux (Item 15, WP 0121-00)

Test Equipment

Multimeter

References

Schematic Diagram, WP 0122-00

Equipment Condition

Main power source is disconnected.

Top covers removed (WP 0019-00).

Circuit breaker removed (WP 0033-00).

WARNING

Disconnect air conditioner power supply.

INSPECTION

1. Inspect all installed wiring for cracked or frayed insulation and loose conductor strands at connections.
2. Repair or replace bad wiring.
3. Inspect electrical connectors for damage.
4. Replace damaged connectors.

MAIN POWER INPUT CONNECTOR (J2) and ALTERNATE POWER INPUT CONNECTOR (J1) – UNIT MAINTENANCE - Continued

0043-00

INSPECTION – Continued

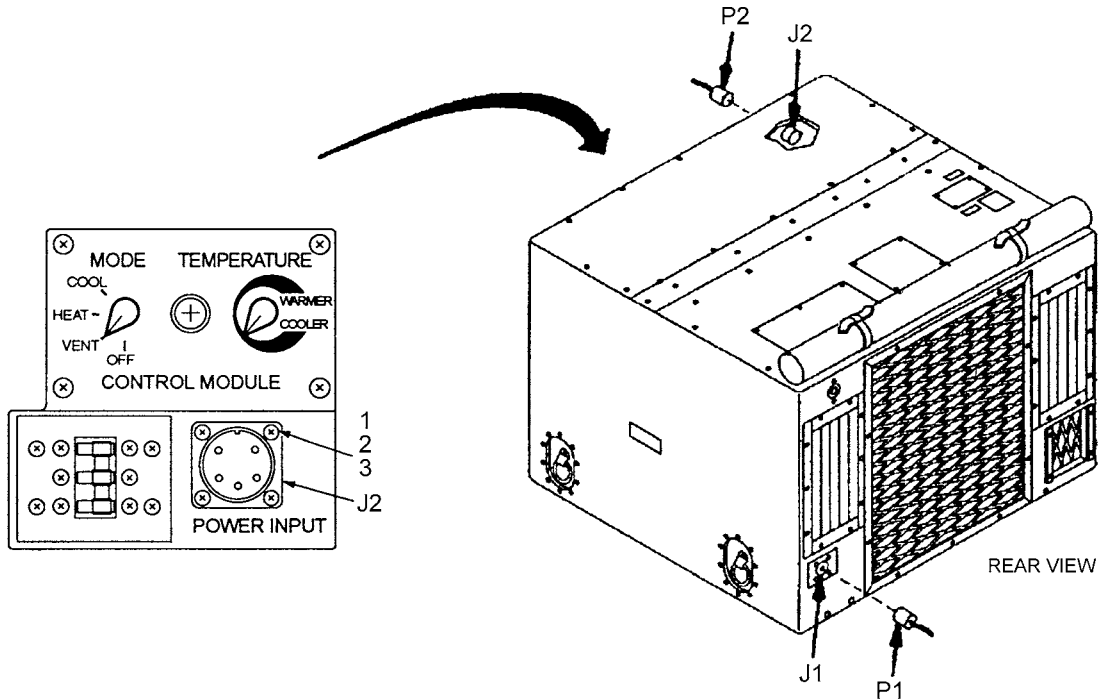

NOTE

Use Schematic Diagram, WP 0122-00 for the following instructions.

REMOVAL

1. Tag all wire leads prior to removal.
2. Refer to WP 0033-00 for J2 connector removal.
3. Remove four screws (1), four washers (2) and four nuts (3) to release each connector from housing.
4. Disconnect all connector plugs , terminals and clamps.

NOTE

The J1 connector is routed thru two oversize clamps in the condenser section bottom and bulkhead.

5. Carefully remove harness from unit. Each connector has a separate harness.

TEST

1. Test for continuity on wiring harness.
2. Touch the test probes of a multimeter, set on low-resistance range, to ends of wire and/or corresponding pin of connector.
3. If continuity is not indicated, repair or replace wire or damaged connector.

MAIN POWER INPUT CONNECTOR (J2) and ALTERNATE POWER INPUT CONNECTOR (J1) – UNIT MAINTENANCE - Continued

0043-00

REPAIR

1. Remove the insulation to expose 1/2 inch/1.27 centimeters of bare wire on each side of break or damaged insulation.
2. Insert the ends into a splice-connector; splice and crimp the connector to make firm electrical contact.
3. Alternatively, heat-shrink tubing may be slipped over one end of the wire before splicing, then heated after the splice is made and soldered, so as to cover the spliced area.
4. Be sure that no bare wire is exposed after the splice is complete.
5. Replace broken terminal lugs with exact duplicates.
6. To replace electrical plugs or connectors, tag and unsolder wires from the solder-wells of the inserts.
7. Insert bare ends of the wires in corresponding holes of new insert, and solder in place.
8. Check continuity terminal-to-terminal.

INSTALLATION

1. Transfer tags to new harness.
2. Refer to WP 0033-00 for J2 connector installation.
3. Install each connector into unit housing with four screws (1), four washers (2) and four nuts (3).
4. Route each harness in the same manor as disassembled.
5. Connect all connector plugs and terminals and remove tags. Use Schematic Diagram, WP 0122-00.
6. Install top covers. See WP 0019-00.

END OF TASK

THIS WORK PACKAGE COVERS:

Removal, Inspection and Installation

INITIAL SETUP:

Maintenance Level

Unit

Tools and Special Tools

Tool Kit, General Mechanics (Item 1, Table 2, WP 0118-00)

WARNING

Disconnect air conditioner power supply.

REMOVAL

1. Remove six screws (1) and flat washers (2) from bottom of air conditioner and enclosure mounting plate (6).
2. Remove six resilient mounts (3), six elastomeric tubes (5) and six spacers (4) from bottom of enclosure mounting plate (6).
3. Remove air conditioner from atop of six remaining resilient mounts (3) and the enclosure mounting plate (6).
4. Remove the remaining six resilient mounts (3) from atop of enclosure mounting plate (6).

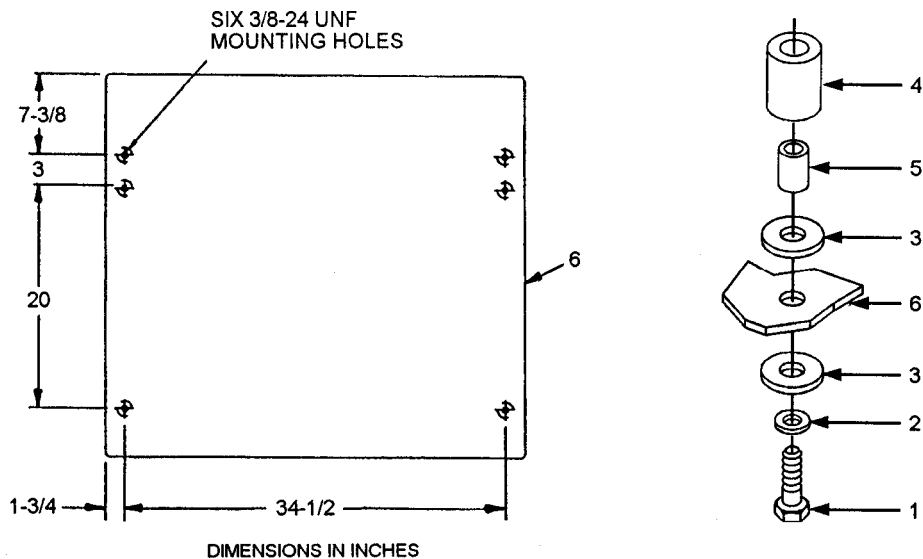

INSPECTION

1. Inspect six screws (1) and flat washers (2) for damage.
2. Inspect twelve resilient mounts (3), six elastomeric tubes (5) and six spacers (4) for damaged or worn out conditions.
3. Replace damaged hardware.

INSTALLATION

1. Assemble onto each of six screws (1), a flat washer (2), a spacer (4), an elastomeric tube (5) and a resilient mount (3).
2. Install the above screws, flat washers, spacers, elastomeric tubes and resilient mounts through the bottom of enclosure plate and then install one additional resilient mount (3) on each of the four screws (1), on top of the enclosure mounting plate (6).
3. Align the air conditioner on top of the resilient mounts (3) and screws (1), which attach the air conditioner to the enclosure mounting plate (6).
4. Tighten the screws (1) into the bottom of air conditioner.

END OF TASK

CHAPTER 7
DIRECT SUPPORT
TROUBLESHOOTING PROCEDURES

MALFUNCTION/SYMPTOM INDEX

The malfunction/symptom index (WP 0009-00 and WP 0046-00) are quick reference indexes for finding troubleshooting procedures. Associated with each symptom name is a work package sequence number representing the starting point in a troubleshooting sequence. Should any one symptom require more than one troubleshooting sequence to arrive at the most likely area of investigation, the additional starting point numbers are presented.

As the troubleshooting activity progresses through to the conclusion of a particular sequence, a reference is made to the next logical troubleshooting sequence by work package sequence number or by referring to the malfunction/symptom index to locate the next failure symptom work package. This type of activity continues until successful fault isolation is achieved.

TROUBLESHOOTING PROCEDURES

The troubleshooting work packages contain tables listing the malfunctions, tests or inspections, and corrective action required to return to the normal operation. Perform the steps in the order they appear in the tables.

Each work package is headed by an initial setup. This setup outlines what is needed as well as certain conditions which must be met before starting the task. **DO NOT START A TASK UNTIL:**

You understand the task.

You understand what you are to do.

You understand what is needed to do the work.

You have the things you need.

This manual cannot list all malfunctions that may occur, or all tests or inspections and corrective actions. If a malfunction is not listed or is not corrected by listed corrective actions, notify your supervisor.

END OF TASK

MALFUNCTION/SYMPTOM	TROUBLESHOOTING PROCEDURE
Compressor Will Not Start	
1. Control circuit may have an open circuit	WP 0047-00
2. Faulty circuit breaker	WP 0047-00
3. Bad continuity of compressor motor or wiring	WP 0047-00
4. Faulty HIGH or LOW pressure switch	WP 0047-00
5. Faulty power input plugs (P2 or P1 alternate)	WP 0047-00
Compressor Starts, But Stops At Once Or After Short Run Period – Due To Tripped Circuit Breaker	
1. Defective circuit breaker	WP 0047-00
Compressor Starts, But Stops At Once Or After Short Run Period – Due To Tripped Low Pressure Switch	
1. Unit activation requires time delay (wait and observe)	WP 0047-00
2. Defective low pressure switch	WP 0047-00
3. System refrigerant loss	WP 0047-00
Compressor Starts, But Stops At Once Or After Short Run Period – Due To Tripped High Pressure Switch	
1. System refrigerant overcharged	WP 0047-00
2. Bad condenser fan or motor	WP 0047-00
3. Obstruction of air flow through condenser, grill or louvers	WP 0047-00
4. Faulty high pressure switch	WP 0047-00
Compressor Starts, But Stops At Once or After Short Run Period – Due To Tripping of Compressor Overload Switch	
1. Faulty compressor	WP 0047-00
2. Faulty expansion valve	WP 0047-00

MALFUNCTION/SYMPTOM	TROUBLESHOOTING PROCEDURE
Insufficient Cooling	
1. Bad filter-drier	WP 0047-00
2. Expansion valve obstructed or damaged	WP 0047-00
3. Insufficient refrigerant or leaks	WP 0047-00
4. Faulty compressor	WP 0047-00
5. Excess refrigerant	WP 0047-00
Compressor Runs But Does Not Cool	
1. Improper power supply	WP 0047-00
2. Excessively high temperature in conditioned area	WP 0047-00
3. Faulty Compressor	WP 0047-00
4. Low refrigerant charge	WP 0047-00
5. High discharge pressure	WP 0047-00
6. Faulty liquid solenoid valve	WP 0047-00
Compressor Excessively Noisy	
1. Low suction line temperature	WP 0047-00
2. Overcharge of refrigerant	WP 0047-00
3. Improper power supply	WP 0047-00
Suction Pressure Too Low	
1. Faulty expansion valve	WP 0047-00
2. Bad filter-drier	WP 0047-00
Suction Pressure Too High	
1. Defective solenoid valve	WP 0047-00
2. Broken or loose louver cables	WP 0047-00
3. Defective actuator cylinder	WP 0047-00
4. Faulty expansion valve	WP 0047-00

MALFUNCTION/SYMPTOM	TROUBLESHOOTING PROCEDURE
Low Heat or No Heat	
1. Loose connections or broken wires	WP 0047-00
2. Poor continuity of mode selector switch and/or temperature control	WP 0047-00
3. Faulty heating elements	WP 0047-00
4. Faulty heater cutout switches	WP 0047-00
5. Faulty heater relay	WP 0047-00
6. Bad evaporator fan or motor	WP 0047-00
END OF TASK	

DIRECT SUPPORT TROUBLESHOOTING PROCEDURES

0047-00

THIS WORKPACKAGE COVERS:

Compressor Will Not Start, Compressor Starts But Stops At Once, Insufficient Cooling, Compressor Runs But Does Not Cool, Compressor Excessively Noisy, Suction Pressure Too Low or Too High, Low Heat or No Heat

INITIAL SETUP:

Maintenance Level

Direct Support

Tools and Special Tools

- Tool Kit, General Mechanics (Item 1, WP 0118-00)
- Tool Kit, Service, Refrigeration Unit (Item 2, WP 0118-00)
- Recovery and Recycle Unit, Refrigerant (Item 5, WP 0118-00)
- Mask, Air Filtering (Item 29, Table 1, WP 0121-00)

Test Equipment:

- Multimeter
- Electronic refrigerant gas leak detector

References

Schematic Diagrams WP 0122-00

Equipment Condition

- Mode selector switch in OFF position.
- Main power source is disconnected.
- Panels removed (WP 0019-00).

WARNING

Disconnect air conditioner power supply.

Table 1. Troubleshooting Procedures

MALFUNCTION	TEST OR INSPECTION	CORRECTIVE ACTION
1. COMPRESSOR WILL NOT START	1. Make continuity check of control circuit and components. See WP 0122-00 for control circuit schematic diagram. (Refer to WP 0034-00.) 2. If fans do not operate, make continuity check of circuit breaker. (Refer to WP 0033-00.)	1. Repair loose or broken connections. 2. Replace bad components. (Refer to WP 0034-00 thru WP 0038-00.) Replace bad circuit breaker. (Refer to WP 0033-00.)

Table 1. Troubleshooting Procedures - Continued

MALFUNCTION	TEST OR INSPECTION	CORRECTIVE ACTION										
<p>1. COMPRESSOR WILL NOT START - Continued</p>	<p>3. Check continuity of compressor motor, and the wiring to motor using multimeter. (Refer to WP 0076-00.)</p> <p>4. Check continuity of HIGH and LOW pressure switches at room temperature. Continuity should exist. (Refer to WP 0072-00.)</p> <p>5. Check power input plugs (P2 or P1 alternate) using multimeter at TB1 as follows:</p> <table border="1" data-bbox="602 869 1018 1079"> <thead> <tr> <th>CONNECTOR PLUG PIN</th> <th>TB1 TERMINAL (See Note)</th> </tr> </thead> <tbody> <tr> <td>A</td> <td>1 or 4</td> </tr> <tr> <td>B</td> <td>2 or 5</td> </tr> <tr> <td>C</td> <td>3 or 6</td> </tr> <tr> <td>E</td> <td>GROUND</td> </tr> </tbody> </table> <p>A to B should be 208 V ac B to C should be 208 V ac A to C should be 208 V ac A to E should be 120 V ac B to E should be 120 V ac C to E should be 120 V ac</p> <p>NOTE</p> <p>When making test for voltage and phase reading, TB1 terminals 4, 5 and 6 are used with P1 alternate plug. Refer to WP 0122-00 schematic diagram.</p>	CONNECTOR PLUG PIN	TB1 TERMINAL (See Note)	A	1 or 4	B	2 or 5	C	3 or 6	E	GROUND	<p>Replace bad compressor or bad wiring. (Refer to WP 0076-00.)</p> <p>1. If continuity does not exist, press reset button and recheck.</p> <p>2. Replace faulty HIGH or LOW pressure switch. (Refer to WP 0072-00.)</p> <p>Replace power input plug which does not pass test. (Refer to WP 0043-00.)</p>
CONNECTOR PLUG PIN	TB1 TERMINAL (See Note)											
A	1 or 4											
B	2 or 5											
C	3 or 6											
E	GROUND											
<p>2. COMPRESSOR STARTS, BUT STOPS AT ONCE OR AFTER SHORT RUN PERIOD - Due To Tripped Circuit Breaker</p>	<p>1. Check compressor for short to ground.</p> <p>2. Check circuit breaker by observing amperes at moment of trip.</p>	<p>Replace bad compressor or bad lead. (Refer to WP 0076-00.)</p> <p>Replace defective circuit breaker. See WP 0033-00.</p>										

Table 1. Troubleshooting Procedures - Continued

MALFUNCTION	TEST OR INSPECTION	CORRECTIVE ACTION
<p>3. COMPRESSOR STARTS, BUT STOPS AT ONCE OR AFTER SHORT RUN PERIOD - Due To Tripped Low Pressure Switch</p>	<p>1. Leave the unit alone for one-minute.</p> <p>2. After one-minute see if compressor comes on.</p> <p>3. Wait another one-minute.</p> <p style="text-align: center;">NOTE</p> <p>Sequence of waiting and observing may occur several times depending on temperature.</p>	<p>Wait.</p> <p>Wait and observe when low pressure switch cuts out.</p> <p>If compressor does not come on, perform continuity test on low pressure switch. Replace defective switch (WP 0072-00).</p>
<p>4. COMPRESSOR STARTS, BUT STOPS AT ONCE OR AFTER SHORT RUN PERIOD – Due to Tripped High Pressure Switch.</p>	<p>1. Perform pressure testing on system to determine if an overcharge of refrigerant is indicated. See WP 0055-00.</p> <p>2. Check for proper operation of condenser fan and motor.</p> <p>3. Inspect condenser coil, intake grill and condenser discharge louvers for dirt, obstructions or closed discharge louver.</p> <p>4. Turn off power ; short-circuit (“jumper”) the high pressure switch. Turn on power, wait one minute for time delay to allow compressor to start. Allow compressor to run for a maximum of 12 seconds to see whether compressor operates normally.</p> <p style="text-align: center;">CAUTION</p> <hr style="width: 20%; margin: auto;"/> <p>Do not exceed 12- second operating time for compressor as high pressure may develop in the refrigeration system that could cause the pressure relief valve to open or may result in damage to the system.</p>	<p>If overcharged, partially discharge the system and retest. See WP 0049-00 and WP 0055-00.</p> <p>Replace bad motor or fan. (Refer to WP 0031-00.)</p> <p>Clean or remove obstruction or set discharge louver to full open. See WP 0041-00.</p> <p>If operation of unit is satisfactory, replace faulty high pressure switch. See WP 0072-00.</p>
<p>5. COMPRESSOR STARTS, BUT STOPS AT ONCE OR AFTER SHORT RUN PERIOD – Due to Tripping of Compressor Internal Overload</p>	<p>1. Check compressor current draw at moment of trip.</p> <p>2. Check for proper operation of refrigerant expansion valve superheat at compressor suction.</p>	<p>If over specified current draw, replace faulty compressor. See WP 0076-00.</p> <p>If in excess of 25°F (-3.88°C) replace expansion valve. See WP 0074-00.</p>

Table 1. Troubleshooting Procedures - Continued

MALFUNCTION	TEST OR INSPECTION	CORRECTIVE ACTION
6. INSUFFICIENT COOLING	<ol style="list-style-type: none"> 1. Feel filter-drier to see whether it is cold to the touch, or is frosted or sweating. 2. Check evaporator coil for overall temperature. 3. Check liquid sight indicator for bubbles or cloudiness, which indicates insufficient refrigerant. 4. Check for high suction and low discharge pressure to see whether compressor is pumping. (Refer to Table 1, WP 0055-00.) 5. Check for high discharge pressure. (Refer to Table 1, WP 0055-00.) 	<p>If so, replace filter-drier. (Refer to WP 0066-00.)</p> <p>If part of coil is relatively warm and evaporator inlet is sweaty or frosty, expansion valve or distributor may be obstructed or damaged. (Refer to WP 0077-00.)</p> <p>Recharge system after checking for and repairing leaks. (Refer to WP 0048-00 through WP 0055-00.)</p> <p>Replace faulty compressor. (Refer to WP 0076-00.)</p> <p>Bleed off excess refrigerant.</p>
7. COMPRESSOR RUNS BUT DOES NOT COOL	<ol style="list-style-type: none"> 1. Check for continuity of temperature selector switch and thermostat (in "COOL" mode). 2. Check electrical rotation of power supply- must be A-B-C for proper compressor rotation. 3. Check for excessively high temperature in conditioned area. 4. Check compressor for noisy operation, high suction pressure or excessively low discharge pressure indicating leaky internal valves. (Refer to WP 0055-00 and Table 1, WP 0055-00.) 5. Check liquid sight indicator for bubbles indicating low charge of refrigerant. 	<p>Replace defective switch (Refer to WP 0034-00 and WP 0035-00.)</p> <p>Refer to schematic diagram (WP 0122-00) for proper connections.</p> <ol style="list-style-type: none"> 1. Close doors, windows or other openings. 2. Insulate areas of high heat gain. <p>Replace compressor. (Refer to WP 0076-00.)</p> <ol style="list-style-type: none"> 1. Repair leaks or replace leaking component. 2. Recharge system. (Refer to WP 0048-00 through WP 0055-00.)

Table 1. Troubleshooting Procedures - Continued

MALFUNCTION	TEST OR INSPECTION	CORRECTIVE ACTION
7. COMPRESSOR RUNS BUT DOES NOT COOL - Continued	6. Check for high discharge pressure. (Refer to Table 1, WP 0055-00.) 7. Check operation of liquid solenoid valve. Unit may be in standby operation.	Bleed off excess refrigerant. 1. Check continuity of solenoid coil. Replace defective coil. 2. Cycle equipment several times. 3. Perform refrigeration system pressure testing for low or expected discharge pressure. Refer to WP 0055-00 for pressure testing.
8. COMPRESSOR EXCESSIVELY NOISY	1. Listen for knocking. 2. Check for high discharge pressure indicating overcharge of refrigerant. (Refer to WP 0055-00 and Table 1, WP 0055-00.) 3. Check three phase power sequence, must be A-B-C for proper compressor rotation.	Check for low suction line temperature indicating that liquid refrigerant is returning to compressor. (Refer to WP 0055-00 and Table 1, WP 0055-00.) 1. Bleed off excess refrigerant. 2. Check HIGH pressure switch. Refer to schematic diagram (WP 0122-00) for proper connections.
9. SUCTION PRESSURE TOO LOW	1. Stop compressor and check expansion valve.	1. Remove remote bulb in suction line. 2. Place bulb in ice water for 1-2 minutes. 3. Start compressor.

Table 1. Troubleshooting Procedures - Continued

MALFUNCTION	TEST OR INSPECTION	CORRECTIVE ACTION
<p>9. SUCTION PRESSURE TOO LOW - Continued</p>	<p>1. Stop compressor and check expansion valve – Continued.</p> <p>2. Feel filter-drier for temperature difference. Discharge end will feel cooler than input end if clogged, or discharge end may be frosty or sweaty (For low suction pressure).</p>	<p>4. Remove bulb from ice water and hold it in one hand to warm it. At the same time, check the suction line for rapid change of temperature, which indicates flood-through of liquid refrigerant. If liquid floods through valve, it is operating satisfactorily. If not, valve or remote bulb is faulty.</p> <p style="text-align: center;">CAUTION</p> <hr style="width: 20%; margin: auto;"/> <p>Do not let liquid flood back into compressor or compressor will be seriously damaged.</p> <p>5. Replace faulty expansion valve. (Refer to WP 0074-00.)</p> <p>Replace filter-drier. (Refer to WP 0066-00.)</p>
<p>10. SUCTION PRESSURE TOO HIGH</p>	<p>1. Check suction line and accumulator for excessive sweating and flood back of liquid to compressor.</p> <p>2. Check for defective actuator cylinder, broken or loose louver actuator cables.</p> <p>3. Test for defective expansion valve.</p>	<p>Expansion valve is stuck open. Replace expansion valve. See WP 0074-00.</p> <p>1. Repair or replace defective actuator cylinder. (Refer to WP 0068-00.)</p> <p>2. Repair or replace louver actuator cables. (Refer to WP 0032-00.)</p> <p>1. Test for properly functioning expansion valve per WP 0074-00.</p> <p>2. Replace defective expansion valve. (Refer to WP 0074-00.)</p>

Table 1. Troubleshooting Procedures - Continued

MALFUNCTION	TEST OR INSPECTION	CORRECTIVE ACTION
<p>11. LOW HEAT OR NO HEAT</p>	<ol style="list-style-type: none"> 1. Check heater wiring and control circuit for loose connections or broken wires. 2. Check continuity of mode selector switch, temperature selector switch and thermostat. (Refer to WP 0034-00 and WP 0035-00.) 3. Disconnect and remove heater elements, and apply 115-volt AC power to check for open circuit in element or check resistance. Element should heat. 4. Check continuity of two heater cutout switches at room temperature. Continuity should exist. (Refer to WP 0027-00.) 5. Disconnect heater relay. Apply 24-28 volts to actuate relay and check continuity at power terminals. Continuity should exist. (Refer to WP 0036-00.) 6. Check operation of evaporator fan and motor. (Refer to WP 0030-00.) 	<ol style="list-style-type: none"> 1. Tighten loose connections. 2. Replace or repair broken wires. (Refer to WP 0027-00, WP 0028-00, WP 0034-00 through WP 0038-00.) <p>Replace faulty switch. (Refer to WP 0034-00 and WP 0035-00.)</p> <p>Replace faulty heating elements. (Refer to WP 0028-00.)</p> <p>Replace faulty switch. See WP 0027-00.</p> <p>Replace faulty relay. (Refer to WP 0036-00.)</p> <p>Repair or replace faulty fan or motor. (Refer to WP 0030-00.)</p>

END OF TASK

CHAPTER 8
DIRECT SUPPORT
MAINTENANCE INSTRUCTIONS

REFRIGERATION SYSTEM DESCRIPTION

0048-00

Description

WARNING

Unit contains R-22, a chemical substance which harms public health and the environment by destroying ozone in the upper atmosphere, and that the equipment is to be serviced by qualified personnel only.

WARNING

Whenever it is necessary to open the refrigeration system for any reason, discharge the refrigerant carefully. Avoid contact with liquid refrigerant. As a minimum, all personnel must wear thermal protective gloves, a face shield or goggles and a air filtering mask when working in any situation to avoid R-22 contact with the skin or eyes. Severe freezing of body tissues can take place with extreme rapidity. Avoid excessive inhalation of refrigerant gas and ventilate the area in which it is released. Refrigerant gas in contact with flame or hot surfaces is converted to phosgene a highly toxic gas having an odor similar to newly mown grass or hay.

1. The refrigeration system illustrated by the refrigerant flow diagram is a mechanical, vapor-cycle circuit consisting of the evaporator thermal expansion valve, compressor, condenser, and the necessary valves and cutout devices for automatic control during operation and servicing.
2. The thermal expansion valve releases high-pressure liquid refrigerant into the evaporator at reduced pressure.
3. The liquid refrigerant begins to vaporize by absorbing heat from the air passing over the outside surface of the evaporator coil.
4. The heated vapor is sucked out of the evaporator section by the compressor, and is forced into the condenser section under high pressure where it is cooled and condensed back into a liquid.
5. The heat released during condensation is carried off by the condensing airstream.
6. The liquid refrigerant flows from the condenser to a filter-drier, sight glass and then to the thermal expansion valve to repeat the cycle.
7. If the temperature control (evaporator return-air thermostat) becomes satisfied (the evaporator return-air temperature is lower than the point at which you have set the control) the refrigeration system will go into "Standby Refrigeration Operating Condition" (no effective cooling but compressor remains operating).
8. When the temperature control again calls for cooling (the evaporator return air temperature is higher than the point at which the control is set) the refrigeration system will come out of the "Standby Refrigeration Operation Condition" to "Full Refrigeration Operating Condition"(full cooling operation). If the system was shut-off (for any reason) the equalization solenoid valve (15) will open equalizing the system pressure and a time delay of one-minute will be encountered before compressor will restart.

Refrigeration System Repair

1. The following paragraphs cover repairs of commonly used hardware, tubing and valves of the refrigeration system. Re-use or repair of seals and gaskets should not be attempted; new parts should be used at assembly. When heating refrigeration piping to debraze or unsolder connections (See Work Package WP 0051-00) as well as to solder or braze them, the piping should be protected with a continuous flow of dry nitrogen to prevent scaling or oxidation of the inside surface.

Refrigeration System Repair – Continued

2. Replace the filter-drier each time a repair is made on the refrigeration system or each time the refrigeration system has been opened.

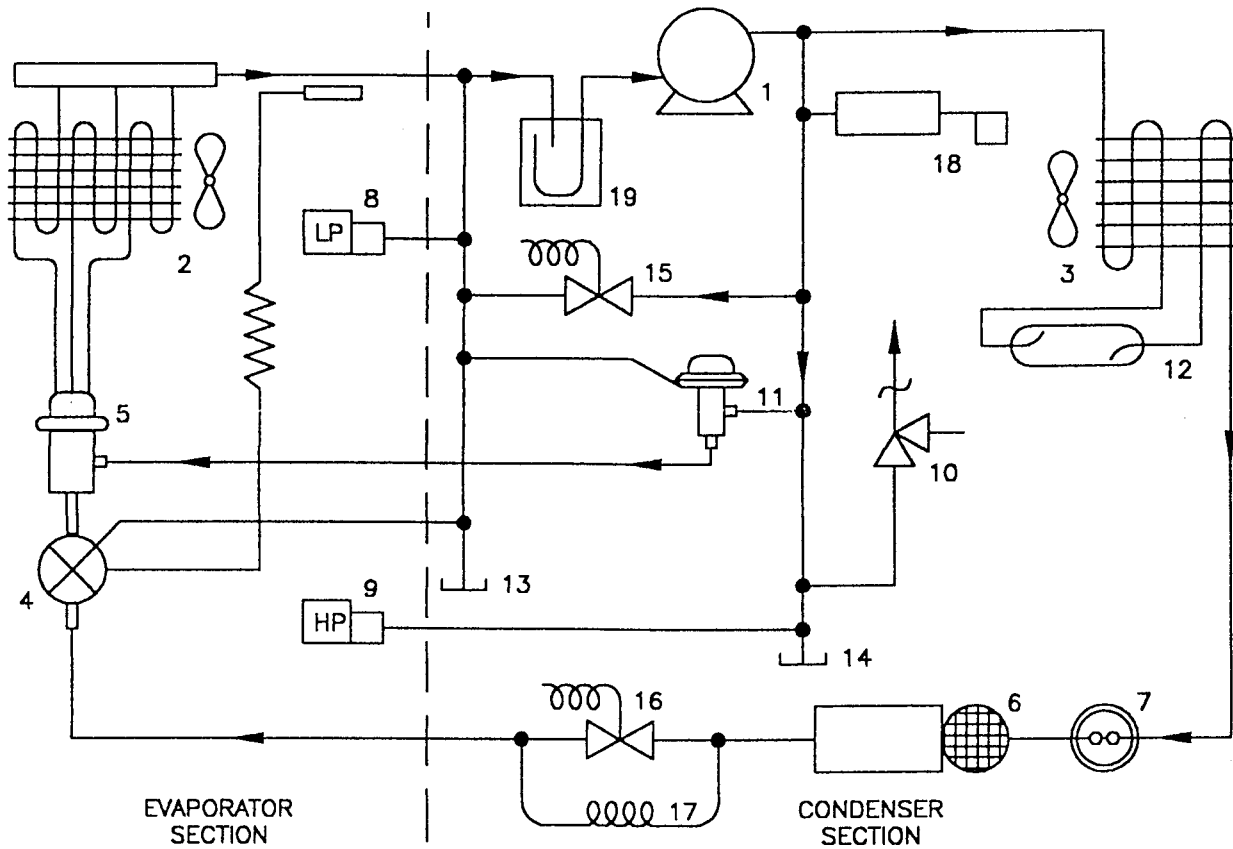

REFRIGERANT SCHEMATIC

LEGEND

1. REFRIGERANT COMPRESSOR - SCROLL
2. EVAPORATOR COIL
3. CONDENSER COIL
4. EXPANSION VALVE - THERMAL
5. REFRIGERANT DISTRIBUTOR - WITH SIDE INLET
6. FILTER - DRIER
7. SIGHT GLASS - MOISTURE INDICATOR
8. LOW PRESSURE SWITCH
9. HIGH PRESSURE SWITCH
10. PRESSURE RELIEF VALVE
11. HOT GAS BY-PASS VALVE
12. RECEIVER
13. LOW SIDE SERVICE VALVE - SHRAEDER
14. HIGH SIDE SERVICE VALVE - SHRAEDER
15. SOLENOID VALVE - EQUALIZATION
16. SOLENOID VALVE - LIQUID LINE
17. CAPILLARY TUBE - DESUPERHEATER
18. ACTUATOR - LINEAR
19. ACCUMULATOR - SUCTION

END OF TASK

REFRIGERATION SYSTEM SERVICING – (DISCHARGING)

0049-00

THIS WORK PACKAGE COVERS:

Service (Discharging)

INITIAL SETUP:

Maintenance Level

Direct Support

Tools and Special Tools

Tool Kit, General Mechanics (Item 1, Table 2, WP 0118-00)

Tool Kit, Service, Refrigeration Unit (Item 2, Table 2 WP 0118-00)

Recovery and Recycle Unit, Refrigerant (Item 5, Table 2, WP 0118-00)

Mask, Air Filtering (Item 29, Table 1, WP 0121-00)

References

WP 0118-00 (MAC)

Equipment Condition

Mode selector switch in OFF position.

Main power source is disconnected.

Panels removed (WP 0019-00).

Air conditioner removed from shelter, if necessary.

Special Environmental Condition

WARNING

In accordance with Environmental Protection Agency regulations, refrigerants cannot be discharged into the atmosphere. A refrigerant recovery and recycling unit must be used whenever discharging the refrigerant system.

Operation of the recovery/recycling unit must be by AUTHORIZED PERSONNEL ONLY.

WARNING

Disconnect air conditioner power supply.

WARNING

Be sure that the manifold hoses are correctly connected. BLUE Hose = Low Pressure, RED Hose = High Pressure.

SERVICE – DISCHARGING**Rear Top of Unit**

1. Remove screws from service valve access cover.
2. Remove service valve access cover.
3. Unscrew hose connection protective caps from service valves.

WARNING

Death or serious injury may result if personnel fail to observe safety precautions. Use great care to avoid contact with liquid refrigerant or refrigerant gas being discharged under pressure. Sudden and irreversible tissue damage can result from freezing. Wear thermal protective gloves and a face protector or goggles in any situation where skin-eye contact is possible.

WARNING

Prevent contact of refrigerant gas with flame or hot surfaces. Heat causes the refrigerant to break down and form carbonyl chloride (phosgene), a highly poisonous and corrosive gas.

4. Connect the charging manifold hoses to the manifold and air conditioner service valves.
5. Attach a hose assembly to the center connection of the manifold.
6. The open end of the center connection hose must be connected to the recovery/recycling unit that is located in a well ventilated area.

WARNING

Discharge refrigerant in an open area and not around an open flame.

CAUTION

Do not permit the oil to escape from the unit. If oil is escaping, close the valve(s) slightly. Do not permit the refrigerant to escape fast enough to form ice or frost on either the lines or the valve.

7. Slowly open the low pressure service valve to allow refrigerant gas to flow slowly out of the hose.
8. Slowly open high pressure service valve to allow refrigerant gas to flow slowly out of the hose.
9. Check the discharge hose for the presence of oil. Adjust (close slightly) valves if necessary to prevent oil discharge.
10. When gas stops flowing, close both service valves.
11. Go to WP 0050-00 for purging the system.

SERVICE – DISCHARGING – Continued

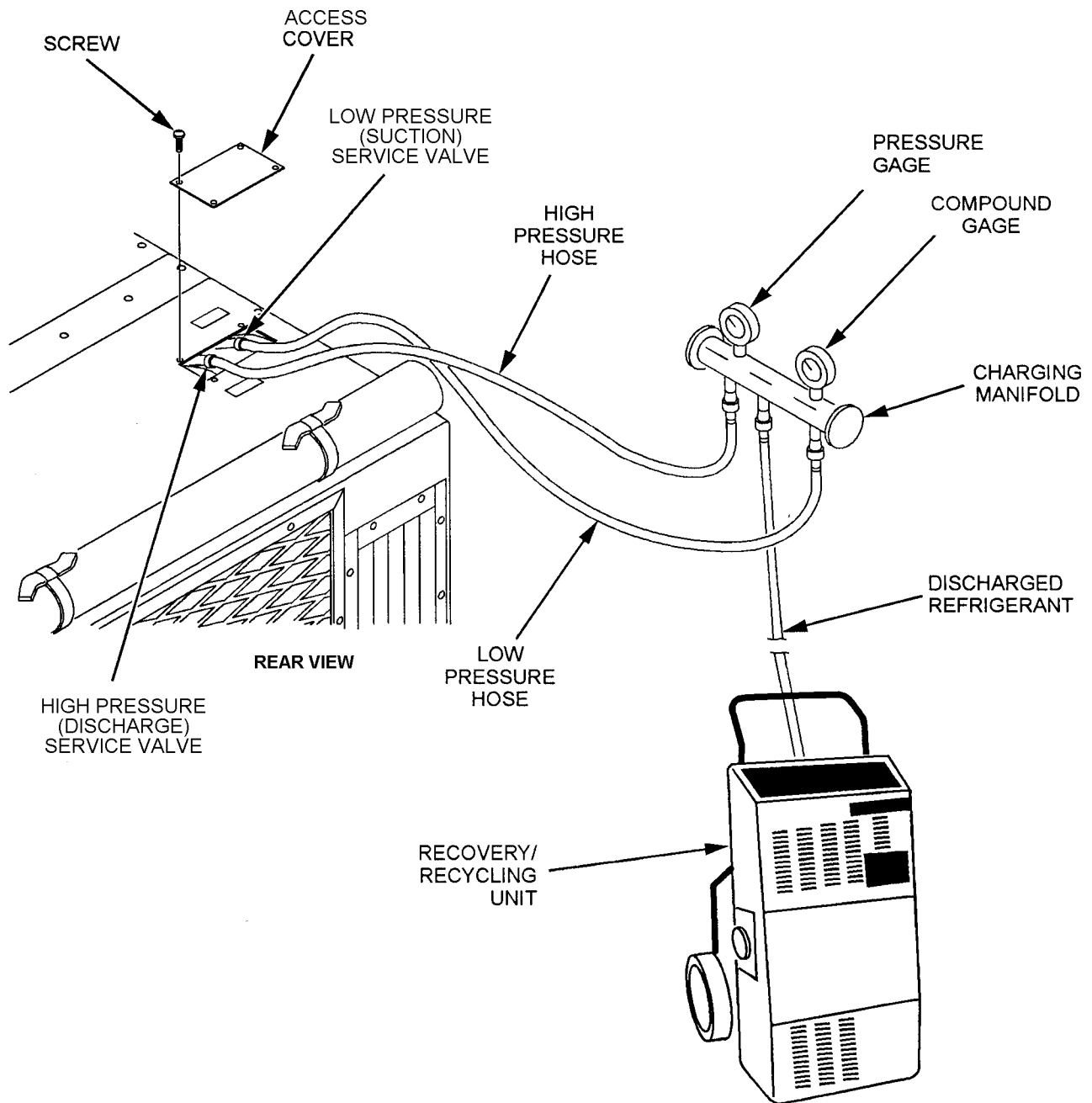

END OF TASK

REFRIGERATION SYSTEM SERVICING – (PURGING)

0050-00

THIS WORK PACKAGE COVERS:

Service (Purging)

INITIAL SETUP:

Maintenance Level

Direct Support

Tools and Special Tools

Tool Kit, General Mechanics (Item 1, Table 2, WP 0118-00)
Tool Kit, Service, Refrigeration Unit (Item 2, Table 2, WP 0118-00)
Nitrogen Pressure Regulator (Item 4, Table 2, WP 0118-00)
Mask, Air Filtering (Item 29, Table 1, WP 0121-00)

Materials/Parts

Nitrogen (Item 4, WP 0121-00)

References

WP 0118-00 (MAC)

Equipment Condition

Refrigerant system discharged (WP 0049-00).
Main power source disconnected.

WARNING

Disconnect air conditioner power supply.

WARNING

Be sure that the manifold hoses are correctly connected. BLUE Hose = Low Pressure, RED Hose = High Pressure.

WARNING

The refrigeration system must be purged with dry nitrogen, during any brazing operation performed on any component. A flow of dry nitrogen at the rate of less than 1 - 2 cfm (0.028-0.057 m³/minute) should be continued during all brazing operations to minimize internal oxidation and scaling.

CAUTION

Nitrogen cylinders are pressurized containers. The pressure in the cylinder can exceed 2000 PSI. A nitrogen pressure regulator must be used at all times when nitrogen is used for leak check or purge operations.

CAUTION

Nitrogen is an inert gas. However, it presents the danger of asphyxiation and therefore, must be discharged in a ventilated location.

SERVICE – PURGING

Verify that the system has been discharged using a manifold as described in WP 0049-00, proceed as follows:

1. See specific component removal/ repair instructions.
2. Be sure that refrigerant has been discharged. (See WP 0049-00.)
3. Connect the center hose from the charging manifold to a nitrogen regulator and dry nitrogen tank.
4. The hose from the high pressure service valve to the charging manifold must be connected.
5. The hose from the low pressure service valve must be disconnected from the charging manifold.
6. Both service valves on the unit will be open by virtue of hose connections.
7. Close the unused valve (suction) on the charging manifold, and open the one (discharge) with the nitrogen tank hooked up.
8. Open the nitrogen cylinder valve and adjust the regulator so that less than 1-2 cfm (0.028-0.057 m³/ minute) of nitrogen flows through system.
9. Check discharge from hose attached to the low pressure service valve to be sure that no oil is being forced out of the system.
10. Allow nitrogen to sweep through the system at the rate of less than 1-2 cfm (0.028-0.057 m³/ minute) for a minimum of 5 minutes, before starting any brazing operation. Then allow it to continue to flow at the same rate until all brazing operations are completed. (See WP 0051-00 for brazing/debrazing procedures.)
11. After installation brazing operations are completed, allow nitrogen to flow for a minimum of 5 minutes.
12. Close nitrogen cylinder valve, nitrogen regulator, and charging manifold valve.
13. Disconnect the hose from the nitrogen tank regulator.
14. When all repairs are completed, go to WP 0052-00 for leak test procedures.

SERVICE – PURGING - Continued

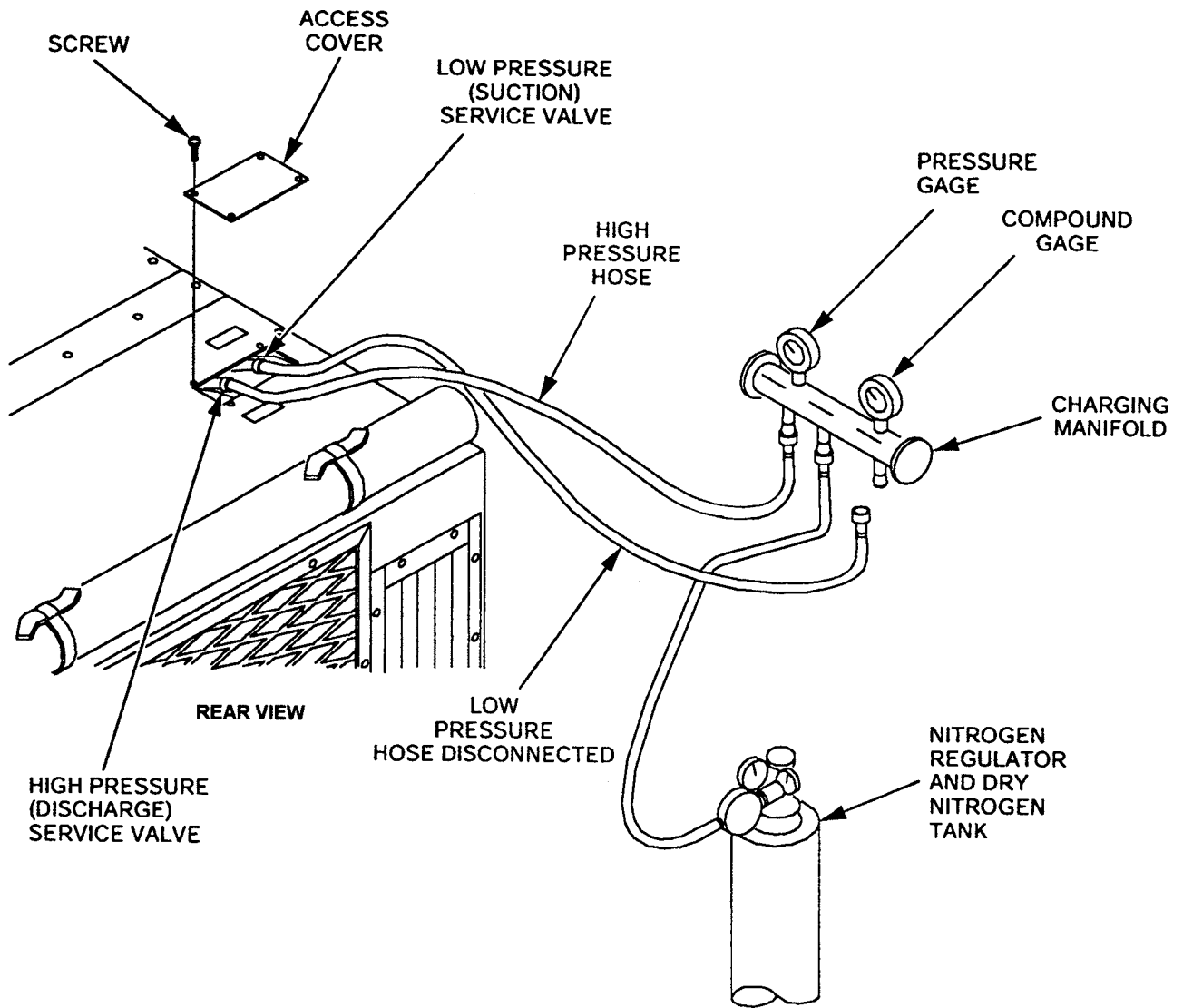

END OF TASK

REFRIGERATION SYSTEM SERVICING – (BRAZING/DEBRAZING)

0051-00

THIS WORK PACKAGE COVERS:

Service (General Information, Filler Alloy, Debrazing, Cleaning Debrazed Joints, Reassembly, Brazing)

INITIAL SETUP:**Maintenance Level**

Direct Support

Tools and Special Tools

Tool Kit, General Mechanics (Item 1, Table 2, WP 0118-00)
Tool Kit, Service, Refrigeration Unit (Item 2, Table 2, WP 0118-00)
Solder, Gun Kit (Item 9, Table 2, WP 0118-00)
Mask, Air Filtering (Item 29, Table 1, WP 0121-00)

Materials/Parts

Brazing alloy (silver) (Items 5 & 6, Table 1, WP 0121-00)
Nitrogen cylinder (Item 4, Table 1, WP 0121-00)
Brazing flux (Item 7, Table 1, WP 0121-00)
Abrasive cloth (Item 8, Table 1, WP 0121-00)
Rags (Item 9, Table 1, WP 0121-00)

References

WP 0118-00 (MAC)

Equipment Condition

Refrigeration system discharged (WP 0049-00).
Refrigeration system purged (WP 0050-00).
Main power source disconnected.

WARNING

Disconnect air conditioner power supply.

WARNING

Be sure that the manifold hoses are correctly connected. BLUE Hose = Low Pressure, RED Hose = High Pressure.

SERVICE**General Information**

All tubing in the refrigeration system is copper with a finish that permits thorough cleaning. All interconnecting fittings, such as elbows, tees, etc., are also copper. The bodies of all valves and all connections on other components are brass. All joints, except those provided with flare fittings, are made by brazing in accordance with MIL-B-7883, except that radiographic examination is not required.

SERVICE - Continued**Filler Alloy Information**

Grade IV or VI brazing alloy and Type B flux, as specified in MIL-B-7883, must be used for all copper to brass joints. Grade III brazing alloy may be substituted for Grade IV or VI for copper to copper joints; flux is not required for copper to copper joints.

Debrazing

Debraze joints for removal of refrigeration system components as follows:

WARNING

All refrigerant-22 must be discharged from the system and the entire system must be purged with dry nitrogen before beginning any debrazing operation.

1. Determine which joints are to be debrazed. Due to the limited work space inside the air conditioner, it may be more convenient to remove a part of the interconnecting tubing with the component rather than debrazing the joints on the component itself.
2. Before debrazing a joint on a valve, disassemble the valve to the extent possible, then wrap all but the joint with a wet rag to act as a heat sink.

WARNING

The elastomeric foam used as insulation in the air conditioner may be damaged and break down to form toxic gasses if exposed to the flame of a torch at brazing temperature.

3. Protect insulation, wiring harnesses, cabinet, and other surrounding components with appropriate shields.
4. Be sure the work area is well ventilated. Be sure the refrigeration system is fully discharged and purged, and that dry nitrogen is flowing through the refrigeration system at a rate of less than 1-2 cfm (0.028- 0.057 m³/minute.)
5. Apply sufficient heat uniformly around the joint to quickly melt the filler alloy. If heat is applied slowly, or only on one side, the entire component or length of tubing will be heated and filler alloy in adjacent joints may also be melted. Remove heat as soon as the joint separates.

Cleaning Debrazed Joints

All filler alloy must be cleaned from debrazed joints before reassembly. Heat each piece of the joint until the filler alloy is melted and then wipe it away with a dry cloth. Be sure no filler alloy or other debris are left inside any tubing, fitting or component.

Reassembly

If tubing sections or fittings were removed with a component, debraze them from the component, clean the joints, and braze them to the new component before reinstallation.

SERVICE - Continued**Brazing**

Braze joints within the air conditioner as follows:

1. Position the component to be installed.
2. To prepare a joint on a valve for brazing, disassemble the valve to the extent possible. Then wrap all but the joint with a wet rag to act as a heat sink.
3. Protect insulation, wiring harnesses, and surrounding components with appropriate shields.
4. Be sure the work area is well ventilated and that dry nitrogen is flowing through the refrigeration system at a rate of less than 1-2 cfm (0.028-0.057 m³/ minute).
5. Apply sufficient heat uniformly around the joint to quickly raise it to a temperature that will melt the filler alloy. Remove heat as soon as brazing is completed.

END OF TASK

REFRIGERATION SYSTEM SERVICING – (LEAK TEST)

0052-00

THIS WORK PACKAGE COVERS:

Service (Leak Test)

INITIAL SETUP:

Maintenance Level

Direct Support

Tools and Special Tools

Tool Kit, General Mechanics (Item 1, Table 2, WP 0118-00)

Tool Kit, Service, Refrigeration Unit (Item 2, Table 2, WP 0118-00)

Mask, Air Filtering (Item 29, Table 1, WP 0121-00)

Test Equipment

Electronic refrigerant gas leak detector (See TM 9-4940-509-14&P)

Materials/Parts

Nitrogen (Item 4, Table 1, WP 0121-00)

Refrigerant R-22 (Item 10, Table 1, WP 0121-00)

References

WP 0049-00

WP 0050-00

WP 0054-00

Equipment Condition

Main power source disconnected.

WARNING

Disconnect air conditioner power.

WARNING

Be sure that the manifold hoses are correctly connected. BLUE Hose = Low Pressure, RED Hose = High Pressure.

NOTE

After repair or replacement of a refrigeration component, replace the filter-drier prior to leak testing. See WP 0066-00.

SERVICE – LEAK TEST**General**

The entire repaired area should be thoroughly leak tested after repair or replacement of any component, before it is recharged with refrigerant-22. Leak testing is also the method for troubleshooting when a system has lost all or part of its refrigerant charge through an undetermined cause.

Testing Method

There are two acceptable methods for leak testing the refrigeration system.

1. Refrigerant gas leak detector. If an electronic refrigerant gas leak detector is available it should be used in accordance with the procedures contained in TM 9-4940-509-14&P, "Leak Detector, Refrigerant Gas".

NOTE

The electronic refrigerant gas leak detector is highly sensitive to the presence of a minute quantity of gas in the air, due to this factor it is quite effective in the detection of a small leak. However, due to the rapid dispersion of refrigerant gas into the surrounding air, difficulty may be encountered in pinpointing large leaks. The detector must be used in a well ventilated but draft-free area.

2. Soap solutions. In this method, a strong solution of a liquid detergent and water is brushed onto all points of possible leakage while closely watching for the formation of bubbles.

Testing Procedure

To perform leak testing by use of the electronic detector, it is necessary that the system be pressurized with a proportion of refrigerant gas. To perform leak testing by use of the soap solution method, the system may be pressurized with dry nitrogen alone.

1. To pressurize a system that has some refrigerant charge, for either leak testing method:
 - a. Remove the hose connection protective caps from the high and low pressure service valves.
 - b. Connect the hoses from a charging manifold to the service valves.

NOTE

If it is possible that the problem may not be a leak and that you may not have to replace a refrigeration system component, refrigerant-22 may be substituted for the nitrogen in the following test. If nitrogen is used, you will have to discharge, evacuate, and recharge the system after this test is completed.

- c. Connect a nitrogen pressure regulator and nitrogen bottle to the center hose connection of the charging manifold.
- d. Open the unit service valves and the charging manifold valves.
- e. Open the nitrogen tank valve and pressurize the system to 300 PSIG (21.2 kg/cm²).
- f. Perform leak tests.

SERVICE – LEAK TEST - Continued**Testing Procedure - Continued**

- g. If a leak is found, discharge and purge the system and repair leak. See specific instructions for components to be removed.
 - h. If a leak was not found and refrigerant-22 was used to pressurize the system, see charging instructions (See WP 0054-00).
 2. To pressurize a system that has been discharged and purged for leak testing with an electronic detector:
 - a. Remove the hose connection protective caps from the high and low pressure service valves.
 - b. Connect the hoses from a charging manifold to the service valves.
 - c. Connect a cylinder of refrigerant-22 to the center hose connection of the charging manifold.

CAUTION

Connect the refrigerant-22 cylinder so that only gas will be used for pressurization.

- d. Open both unit service valves and the charging manifold valves.
 - e. Open the refrigerant cylinder valve slightly and adjust as necessary to prevent formation of frost, and allow system pressure to build up until the gauges read 40-50 PSI (2.8-3.5 kg/cm²).
 - f. Close the charging manifold valves and the refrigerant cylinder valve.
 - g. Remove the refrigerant-22 cylinder from the center hose connection.
 - h. Connect a nitrogen regulator of dry nitrogen to the center hose connection.
 - i. Open the charging manifold valves and the nitrogen cylinder and regulator valve. Allow system pressure to build up until gauges read 300 PSIG (21.2 kg/cm²).
 - j. Perform leak tests, then discharge and purge the system, in accordance with WP 0049-00 and WP 0050-00 before performing maintenance, or before evacuating and charging the system, as appropriate.
 3. Final leak testing. Always perform a final leak test after performing any repair or replacement of components before the air conditioner is reassembled and the refrigeration system is evacuated and charged.

END OF TASK

REFRIGERATION SYSTEM SERVICING – (EVACUATION)

0053-00

THIS WORK PACKAGE COVERS:

Service (Evacuation)

INITIAL SETUP:

Maintenance Level

Direct Support

Tools and Special Tools

Tool Kit, General Mechanics (Item 1, Table 2, WP 0118-00)

Tool Kit, Service, Refrigeration Unit (Item 2, Table 2, WP 0118-00)

Mask, Air Filtering (Item 29, Table 1, WP 0121-00)

Test Equipment

Vacuum pump (Item 3, Table 2, WP 0118-00)

Materials/Parts

Nitrogen (Item 4, Table 1, WP 0121-00)

References

WP 0118-00 (MAC)

WP 0076-00

WP 0052-00

WP 0054-00

Equipment Condition

Refrigerant system leak tested (WP 0052-00).

Refrigerant system discharged (WP 0049-00).

Main power source disconnected.

WARNING

Disconnect air conditioner power supply.

WARNING

Be sure that the manifold hoses are correctly connected. BLUE Hose = Low Pressure, RED Hose = High Pressure.

CAUTION

Do not evacuate a leaking system. The vacuum created can cause air, moisture, and dirt to enter system.

NOTE

Replace filter-dryer whenever refrigerant system is opened.

NOTE

In the event the compressor was replaced as a result of burn-out, check that compressor burn-out procedures were followed. See WP 0076-00.

SERVICE – EVACUATION

1. Connect the hose from the low pressure service valve to the compound gauge side of the charging manifold. The hose from the high pressure service valve shall be connected to the high pressure gauge side of the charging manifold.
2. Open both service valves.
3. Attach center hose assembly charging manifold to vacuum pump.
4. Start vacuum pump.
5. Open charging manifold valves.
6. Run the vacuum pump until approximately a 300 micron vacuum is reached.

NOTE

Inability to reach 300 microns may indicate either a leak or a problem with the pump.

7. Close manifold valves and check compound gauge. Record reading. Let unit sit for one hour. Observe compound gauge reading.
8. If the system holds the vacuum without change of pressure, proceed to step 10.
9. If the vacuum cannot be held for one hour, one of the following reasons may account for the problem:
 - a. Presence of water vapor in the system. Continued pumping will correct this condition.
 - b. Leak in the refrigeration system. Break the vacuum with dry nitrogen and retest for leaks. See WP 0052-00.
 - c. Internal leakage of vacuum pump. Test the pump by connecting a vacuum gauge directly to the vacuum pump intake and continue to pump. If pump still fails to reach approximately 300 microns, the pump is faulty.
10. Close charging manifold valves.
11. Stop vacuum pump.
12. Disconnect pump from center hose connection.
13. Charge system with refrigerant-22. See WP 0054-00.

SERVICE – EVACUATION - Continued

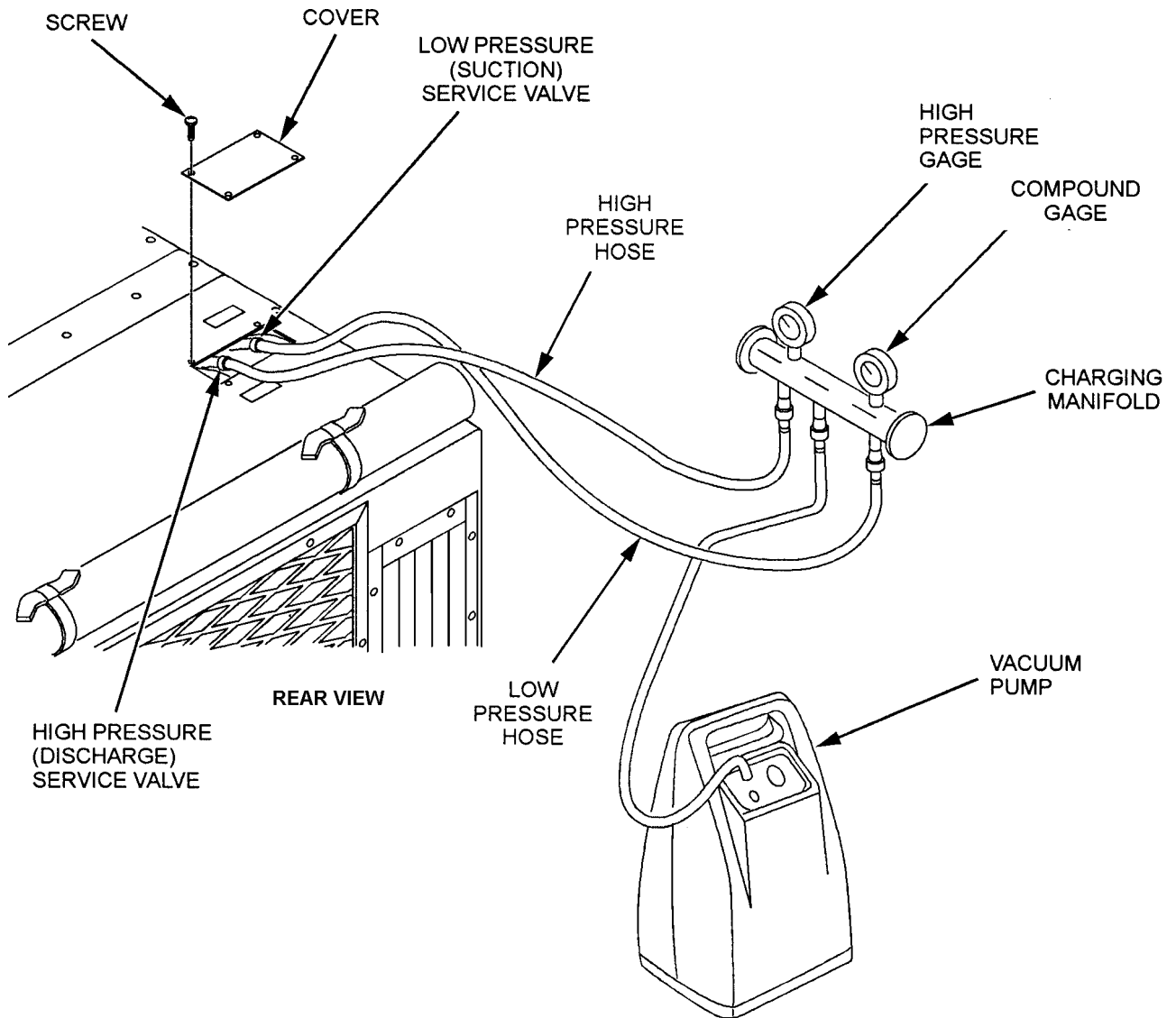

END OF TASK

REFRIGERATION SYSTEM SERVICING – (CHARGING)

0054-00

THIS WORK PACKAGE COVERS:

Service (Charging)

INITIAL SETUP:

Maintenance Level

Direct Support

Tools and Special Tools

Tool Kit, General Mechanics (Item 1, Table 2, WP 0118-00)

Tool Kit, Service, Refrigeration Unit (Item 2, Table 2, WP 0118-00)

Mask, Air Filtering (Item 29, Table 1, WP 0121-00)

Test Equipment

Charging cylinder or scale

Materials

Refrigerant-22, R-22 (Item 10, Table 1, WP 0121-00)

References

WP 0118-00 (MAC)

Equipment Condition

Refrigeration system evacuated (WP 0053-00).

Main power source disconnected.

WARNING

Disconnect air conditioner power supply.

WARNING

Be sure that the manifold hoses are correctly connected. BLUE Hose = Low Pressure, RED Hose = High Pressure.

CAUTION

Never introduce liquid refrigerant into the low pressure (suction) service valve.

NOTE

Install top covers before charging unit.

NOTE

TM 9-4120-425-14&P

After the system has been satisfactorily evacuated, it must be fully charged with R-22.

SERVICE – CHARGING

1. Connect the hose from the low pressure service valve to the compound gauge side of the charging manifold. The hose from the high pressure service valve should be connected to the high pressure gauge side of the manifold.
2. Connect the center hose from the charging manifold to a well charged cylinder of refrigerant-22, or a charging cylinder.
3. Loosen the hose connection to the center of charging manifold.
4. Open the refrigerant-22 or charging cylinder valve slightly to allow a small amount of refrigerant to purge air from the hose. Tighten the hose connection at the charging manifold.
5. Using accurate scales, measure and record the weight of the charged refrigerant-22 cylinder.
6. Fully open the refrigerant-22 cylinder valve.
7. Open the low pressure valve of the charging manifold. Allow refrigerant gas to enter the system until the system pressure has equalized.
8. Connect power to air conditioner.
9. Press and release high pressure switch reset button. It may be necessary to jumper low pressure switch.
10. Turn air conditioner on and operate in the COOL mode with the temperature control thermostat set at a maximum COOLER position.
11. Monitor the weight of the refrigerant cylinder as the air conditioner compressor pulls additional refrigerant gas into the system until the full 6.00 pounds (2.72 kg) charge is obtained. When the system is fully charged immediately close the refrigerant cylinder valve, and the charging manifold low pressure (suction) valve.
12. Run the air conditioner in COOL mode with temperature control thermostat in full COOLER position for 15 minutes.

NOTE

Do not skip the next step.

SERVICE – CHARGING - Continued

13. After 15 minutes, observe the liquid sight indicator (sight glass) on left rear of unit.
 - a. Green center means the refrigerant moisture content is acceptable.
 - b. Yellow center means there is too much moisture in the system. It must be discharged, evacuated and charged again.
 - c. Milky white or bubbly liquid means the system has a low charge.
 - d. Clear bubble-free liquid around the center means the system is fully charged.
14. If charge is low, add more gas refrigerant.
 - a. Open cylinder valve and the manifold low pressure valve.
15. Check air conditioner for proper cooling. There should be at least a 15°F temperature difference between evaporator discharge air and intake air. Turn mode selector switch to OFF.
16. Remove charging manifold hoses.
17. Install service valve protective caps.
18. Secure service valve access cover using four screws.

SERVICE – CHARGING - Continued

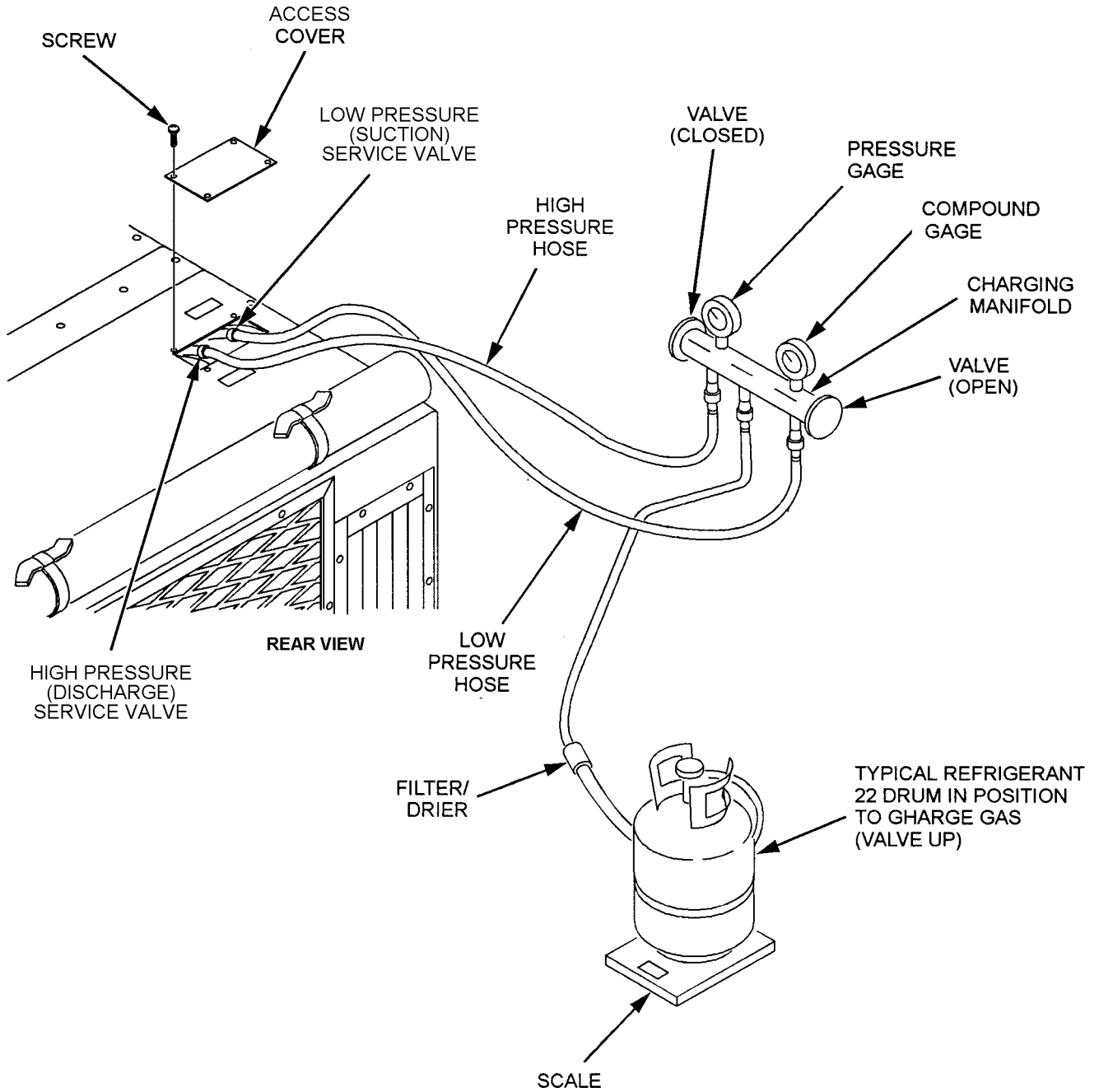

END OF TASK

REFRIGERATION SYSTEM SERVICING – (PRESSURE TESTING)

0055-00

THIS WORK PACKAGE COVERS:

Service (Pressure Testing)

INITIAL SETUP:

Maintenance Level

Direct Support

Tools and Special Tools

Tool Kit, General Mechanics (Item 1, Table 2, WP 0118-00)

Tool Kit, Service, Refrigeration Unit (Item 2, Table 2, WP 0118-00)

Mask, Air Filtering (Item 29, Table 1, WP 0121-00)

References

WP 0118-00 (MAC)

Equipment Condition

Main power source is disconnected.

SERVICE – PRESSURE TESTING

WARNING

Disconnect air conditioner power.

WARNING

Be sure that the manifold hoses are correctly connected. BLUE Hose = Low Pressure, RED Hose = High Pressure.

Service Valve Access Cover

1. Remove screws from service valve access cover.
2. Remove service valve access cover.

Charging Valve Caps

Remove caps from high and low pressure service valves.

Refrigeration System Pressure Testing

1. Connect low pressure gauge hose of manifold valve to suction service valve.
2. Check that manifold valves are closed.
3. Connect high pressure hose of manifold valves to discharge service valve.
4. Purge hoses - open momentarily and close discharge and suction hose connections at charging manifold.

SERVICE – PRESSURE TESTING - Continued

Refrigeration System Pressure Testing – Continued

5. Start air conditioner. With the unit operating, allow gauges to stabilize. Take reading of the two gauges.
6. Compare gauge readings with the normal range of system pressure as shown on the Table of Normal Temperature – Pressure Relationships.
7. Disconnect gauges.
8. Install service valve access cover with screws.

Table 1. Normal Temperature - Pressure Relationships

Temperatures Outdoor Ambient Evaporator Intake	Pressure Range (PSIG)			
	50°F (10°C)	75°F (24°C)	100°F (38°C)	120°F (52°C)
90°F (32°C) Air to Unit (Dry Bulb)	55-65 Suction 150- 180 Discharge	66-76 Suction 200- 240 Discharge	76-86 Suction 280- 325 Discharge	95-100 Suction 390- 428 Discharge
80°F (27°C) Air to Unit (Dry Bulb)	50-60 Suction 140- 170 Discharge	61-71 Suction 190- 230 Discharge	71-81 Suction 270- 315 Discharge	80-90 Suction 360- 410 Discharge

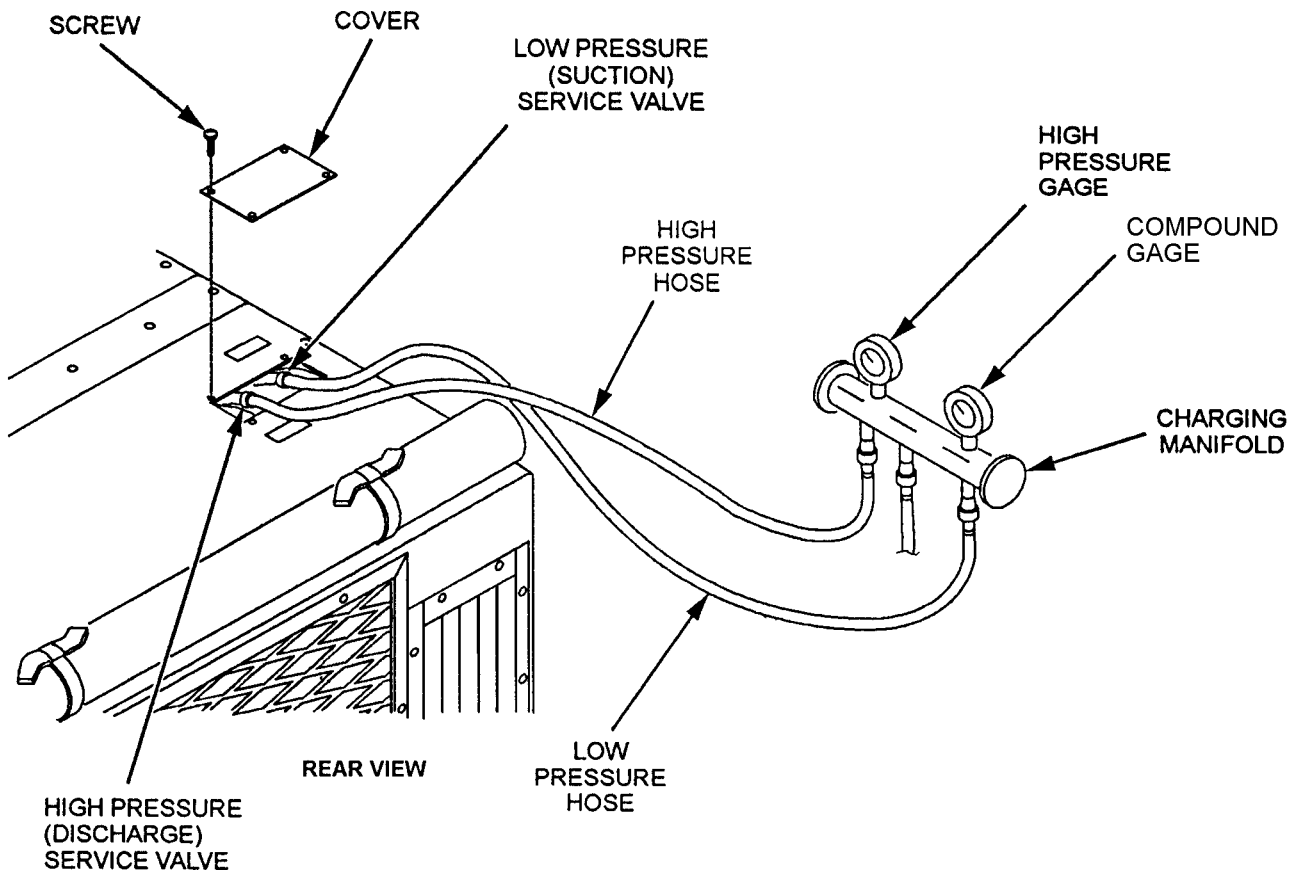

END OF TASK

CONDENSATE DRAIN ASSEMBLY DIRECT SUPPORT MAINTENANCE

0056-00

THIS WORK PACKAGE COVERS:

Removal, Disassembly, Cleaning, Repair and Installation

INITIAL SETUP:

Maintenance Level

Direct Support

Tools and Special Tools

Tool Kit, General Mechanics (Item 1, Table 2, WP 0118-00)

Equipment Condition

Air conditioner shut down and cool.
Front top cover removed (WP 0019-00).
Evaporator louvers removed (WP 0020-00).
Evaporator fan assembly removed (WP 0057-00).
Condenser fan scroll nearest condensate drain assembly removed (WP 0062-00).

Materials/Parts

Water, warm soapy
Wire, soft 10-12 gage
Bleach and water solution, mild

References

WP 0029-00 (Condensate Drain Assembly Unit Maintenance)

WARNING

Disconnect air conditioner power.

REMOVAL AND DISASSEMBLY

1. Loosen clamps (1) and (3).
2. Remove tubing (2) and (4).
3. Refer to Unit Maintenance WP 0029-00 for maintenance of items (6).

CLEANING

1. Clean tubing using warm soapy water or replace. Rinse with mild solution of bleach and water. Replace tubing if defective.
2. Clear obstructions from drains at bottom of evaporator compartment using soft wire. Rinse area with bleach solution.
3. Clear obstructions from drain outlet using soft wire. Insert wire from evaporator drain opening.

REPAIR

1. Replace damaged tubing, or hose clamps as necessary.

INSTALLATION

1. Install tubing (4) and two clamps (3).
2. Install tubing (2) and install and tighten clamps (1).

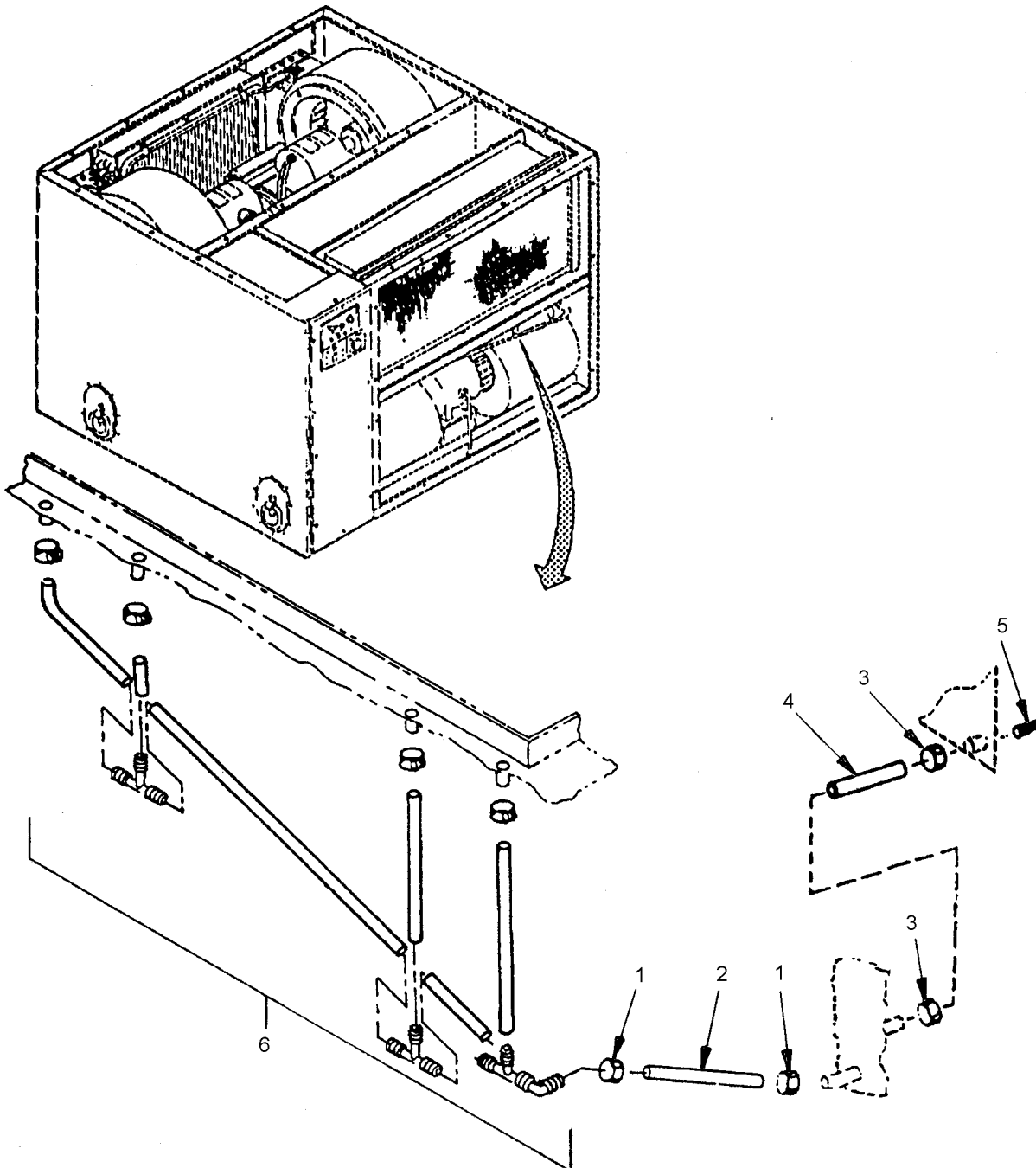

INSTALLATION - Continued

3. Install condenser fan scroll. See WP 0062-00.
4. Install evaporator fan assembly. See WP 0057-00.
5. Install evaporator air louvers. See WP 0020-00.

END OF TASK

EVAPORATOR FAN ASSEMBLY DIRECT SUPPORT MAINTENANCE

0057-00**THIS WORK PACKAGE COVERS:**Removal, Repair and Installation

INITIAL SETUP:**Maintenance Level**

Direct Support

Tools and Special Tools

Tool Kit, General Mechanics (Item 1, Table 2, WP 0118-00)

Screwdriver, Cross Tip (Item 12, Table 2, WP 0118-00)

Equipment Condition

Main power source is disconnected, shut down and cool.

Evaporator air intake louver removed (WP 0020-00).

Heating elements removed (WP 0027-00).

Remote control module partially removed (WP 0034-00).

Disconnect drain hoses (WP 0029-00).

MaterialGrease, General Purpose (Item 28, Table 1, WP 0121-00)

WARNING

Disconnect air conditioner power.

CAUTION

While removing and assembling fan assembly don't hold evaporator fan assembly by the impeller fan. Excess holding pressure may damage fan impeller. Also, take care not to damage evaporator coil.

REMOVAL

1. Loosen screws holding junction box support bracket to aid in fan assembly removal (WP 0035-00).
2. Tag and disconnect terminals 10 and 11 on terminal board TB2 located in remote control module. Disconnect ground wire.
3. Remove screw (1) and lockwasher (2) to remove clamp (3) holding electronic sensor (4). Move sensor to clear housing.
4. Using a cross tip screwdriver (Item 12, Table 2, WP 0118-00) remove two screws (5), two flat washers (6), and two nuts (7).
5. Remove four screws (8), four lock washers (9), and two scroll ducts (10).

REMOVAL - Continued

6. Using a No. 3 screwdriver remove four screws (11) holding evaporator fan assembly (12) to cabinet.
7. Angle assembly to the left to remove evaporator fan assembly (12) from unit.

REPAIR

Repair is limited to replacement of defective parts.

INSTALLATION

1. Place evaporator fan assembly (12) into unit.
2. Using No.3 screwdriver install four screws (11) to attach the evaporator fan assembly (12) to cabinet.
3. Install two scroll ducts (10), four lock washers (9), and four screws (8).
4. Using a cross tip screwdriver (Item 12, Table 2, WP 0118-00), install two nuts (7), two flat washers (6), and two screws (5).
5. Install electronic sensor (4), with clamp (3), lock washer (2), and screw (1) onto evaporator fan assembly (12) frame.
6. Connect two evaporator fan wires to terminal board TB2 in the remote control unit and remove tags. Connect ground wire.
7. Install heating elements. See WP 0027-00.
8. Install evaporator air intake louver. See WP 0020-00.
9. Install remote control module. See WP 0034-00.
10. Reassemble junction box support bracket. Refer to WP 0035-00.
11. Reconnect drain hoses (WP 0029-00).
12. Reconnect air conditioner to power source.

INSTALLATION - Continued

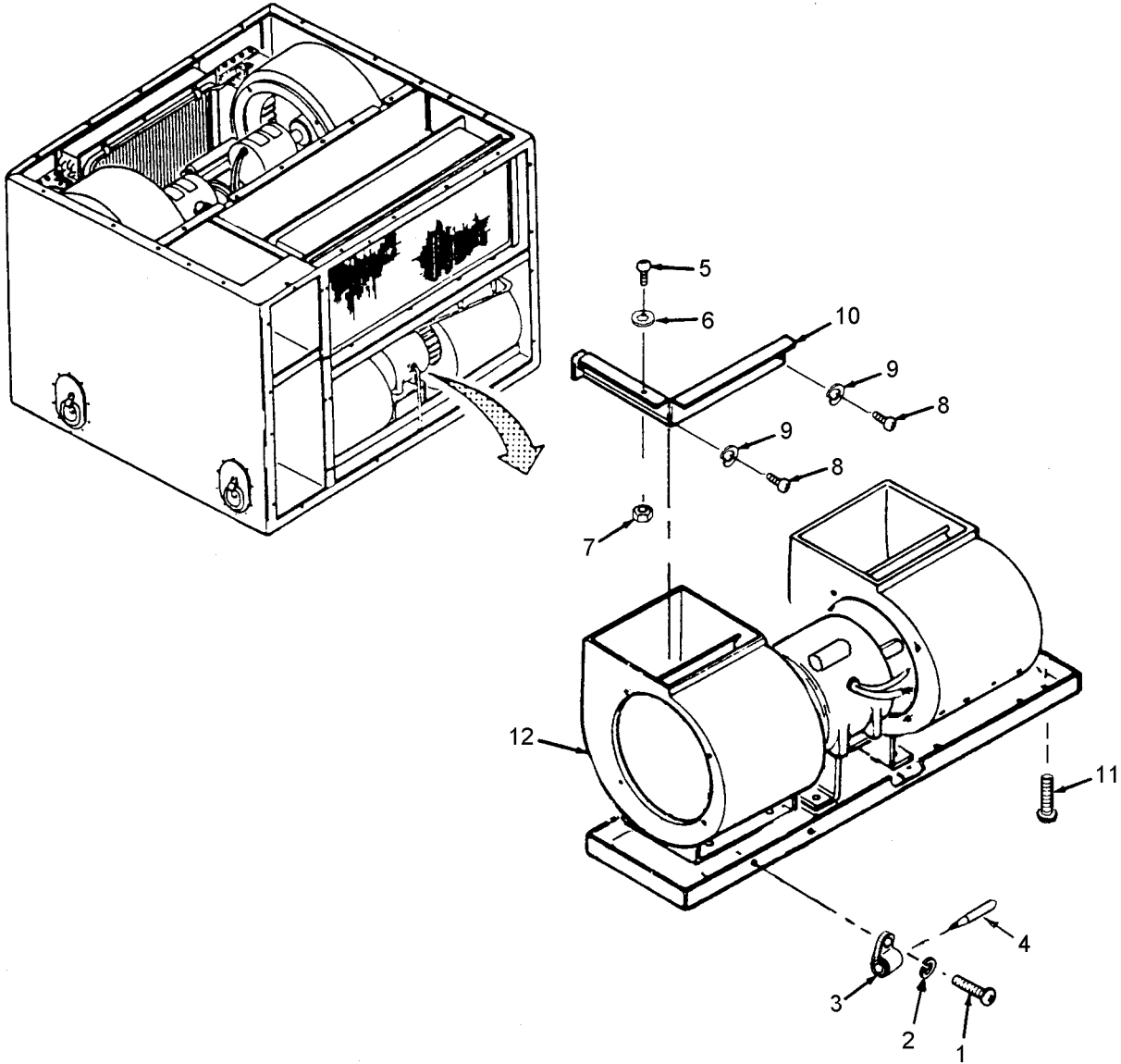

END OF TASK

EVAPORATOR IMPELLER FANS DIRECT SUPPORT MAINTENANCE REPLACEMENT

0058-00**THIS WORK PACKAGE COVERS:**Removal and Installation

INITIAL SETUP:**Maintenance Level**

Direct Support

Tools and Special Tools

Tool Kit, General Mechanics (Item 1, Table 2, WP 0118-00)

Key, Socket Head Screw (Item 13, Table 2, WP 0118-00)

Equipment Condition

Main power source is disconnected, shut down and cool.

Evaporator air intake louver removed (WP 0020-00).

Evaporator fan assembly removed (WP 0057-00).

Evaporator fan scrolls removed (WP 0058-00).

WARNING

Disconnect air conditioner power.

REMOVAL

1. Using a socket head screw key (Item 13, Table 2, WP 0118-00) loosen set screw (1) and impeller fan (2) from evaporator fan assembly.
2. Remove inlet ring (3).
3. Repeat for other impeller fan if other fan is being replaced.

INSTALLATION**NOTE**

Be sure to coat motor shaft with general purpose grease (Item 28, Table 1, WP 0121-00) to aid in assembly of impeller fan on motor shaft.

1. Place inlet ring (3) onto motor shaft (4).
2. Install impeller fan (2) onto motor shaft (4) and loosely tighten set screw (1).
3. Repeat for other impeller fan.
4. Install evaporator fan scrolls. See WP 0058-00.
5. Center impeller fan (2) in evaporator fan scroll and tighten set screw (1) using a socket head screw key (Item 13, Table 2, WP 0118-00).
6. Spin both impeller fans to ensure fans do not rub against scrolls.

**EVAPORATOR IMPELLER FANS DIRECT SUPPORT MAINTENANCE
REPLACEMENT - Continued**

0058-00

INSTALLATION - Continued

7. Repeat for other impeller fan if removed.
8. Install evaporator fan assembly. See WP 0057-00.
9. Install return air louver. See WP 0020-00.

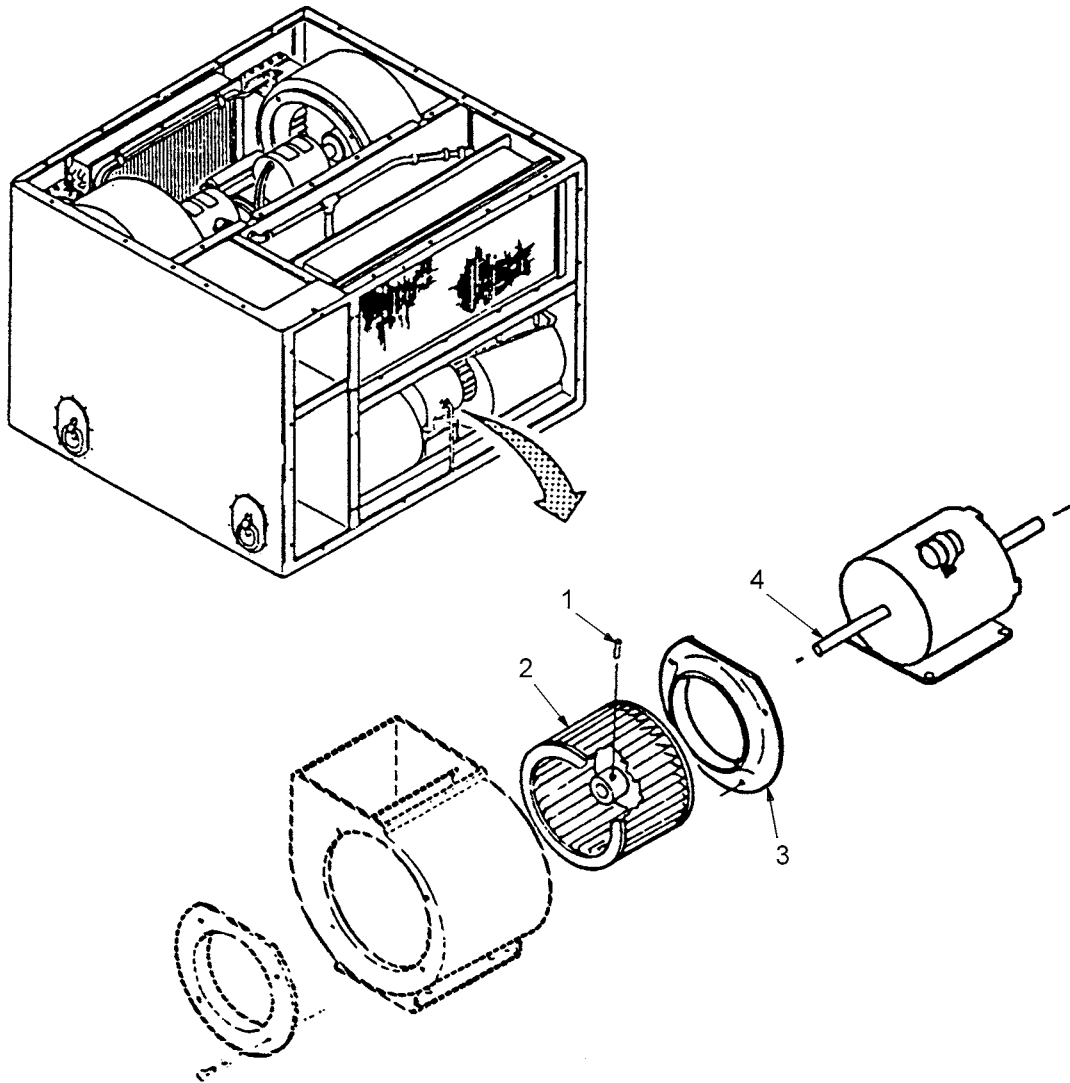
**END OF TASK**

EVAPORATOR FAN SCROLLS DIRECT SUPPORT MAINTENANCE REPLACEMENT

0059-00

THIS WORK PACKAGE COVERS:

Removal and Installation

INITIAL SETUP:

Maintenance Level

Direct Support

Tools and Special Tools

Tool Kit, General Mechanics (Item 1, Table 2, WP 0118-00)

Equipment Condition

Main power source is disconnected, shut down and cool.

Evaporator air intake louver removed (WP 0020-00).

Evaporator fan assembly removed (WP 0057-00).

WARNING

Disconnect air conditioner power.

REMOVAL

1. Remove four screws (1), four flat washers (2), and inlet bell (3) from scroll (9).
2. Remove four screws (7), four flat washers (8), holding evaporator fan scroll (9) to chassis (11).
3. Repeat for other side if other evaporator fan scroll is being replaced.

INSTALLATION

1. Place evaporator fan scroll (9) onto evaporator fan assembly.
2. Loosely install four flat washers (8) and four screws (7).
3. Adjust evaporator fan scroll (9) until it is centered around evaporator impeller fan (10).
4. Tighten four flat washers (8) and four screws (7).
5. Install inlet bell (3), four flat washers (2), and four screws (1).
6. Repeat for other side if both evaporator fan scrolls were removed.
7. Install evaporator fan assembly. See WP 0057-00.
8. Install return air louver. See WP 0020-00.

EVAPORATOR FAN SCROLLS DIRECT SUPPORT MAINTENANCE
REPLACEMENT – Continued

0059-00

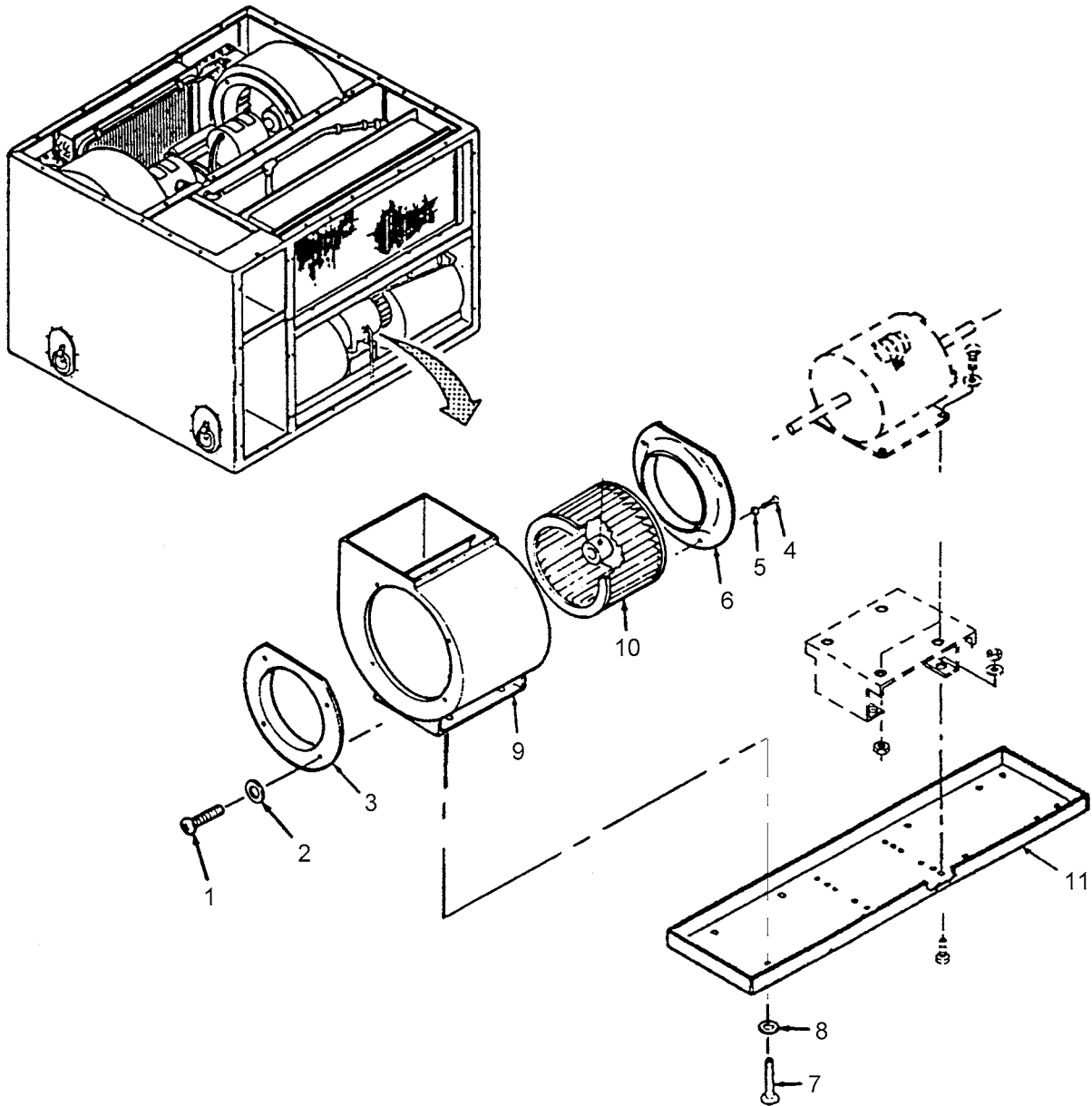

END OF TASK

EVAPORATOR FAN MOTOR DIRECT SUPPORT MAINTENANCE REPLACEMENT

0060-00

THIS WORK PACKAGE COVERS:Removal and Installation

INITIAL SETUP:**Maintenance Level**

Direct Support

Tools and Special Tools

Tool Kit, General Mechanics (Item 1, Table 2, WP 0118-00)

Equipment Condition

Main power source is disconnected, shut down and cool.

Evaporator air intake louver removed (WP 0020-00).

Evaporator fan assembly removed (WP 0057-00).

Evaporator fan scrolls removed (WP 0058-00).

Evaporator impeller fans removed (WP 0059-00).

ReferencesWP 0030-00 (Evaporator fan motor test)

WARNING

Disconnect air conditioner power input connector.

REMOVAL

1. Before removing motor, mark the direction of motor rotation on chassis.
2. Remove four screws (1), four flat washers (2) and four nuts (3).
3. Remove evaporator motor (4) from evaporator motor bracket (5).
4. Evaporator motor bracket (5) can remain in place on chassis (9) unless damaged. Replace if damaged.

INSTALLATION**NOTE**

Install evaporator motor so that direction of rotation arrow matches rotation mark on motor chassis.

1. Place evaporator motor (4) onto evaporator motor bracket (5).
2. Install four flat washers (2), four screws (1) and four nuts (3).
3. Refer to wire tags installed during removal and install motor wiring as required. Remove temporary wire tags. See schematic diagram WP 0122-00.
4. Install evaporator impeller fans. See WP 0059-00.

**EVAPORATOR FAN MOTOR DIRECT SUPPORT MAINTENANCE
REPLACEMENT - Continued**

0060-00

INSTALLATION – Continued

5. Install evaporator fan scrolls. See WP 0058-00.
6. Install evaporator fan assembly. See WP 0057-00.
7. Install return air louver. See WP 0020-00.
8. Reconnect air conditioner to power source.

EVAPORATOR FAN MOTOR DIRECT SUPPORT MAINTENANCE
REPLACEMENT - Continued

0060-00

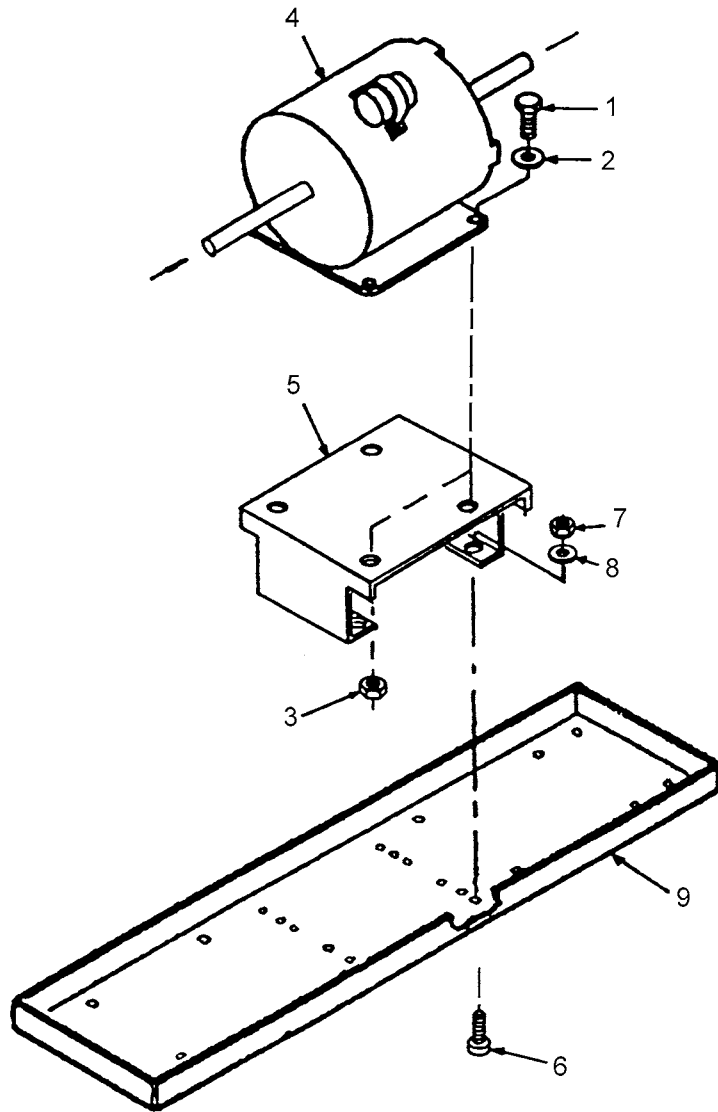
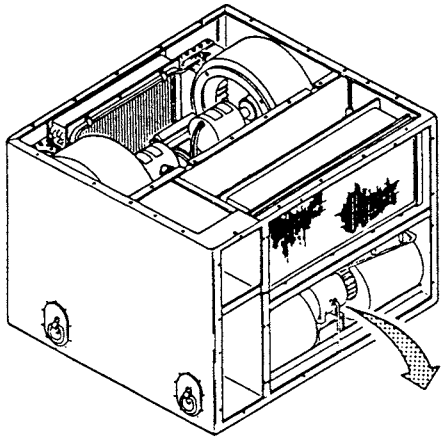

END OF TASK

**EVAPORATOR MOTOR BRACKET AND CHASSIS DIRECT SUPPORT MAINTENANCE
REPLACEMENT**

0061-00

THIS WORK PACKAGE COVERS:

Removal and Installation

INITIAL SETUP:

Maintenance Level

Direct Support

Tools and Special Tools

Tool Kit, General Mechanics (Item 1, Table 2, WP 0118-00)

Equipment Condition

Main power source is disconnected, shut down and cool.
Evaporator air intake louver removed (WP 0020-00).
Evaporator fan assembly removed (WP 0057-00).
Evaporator fan scrolls removed (WP 0058-00).
Evaporator impeller fans removed (WP 0059-00).
Evaporator motor removed (WP 0060-00).

WARNING

Disconnect air conditioner power input connector.

REMOVAL

1. Remove four screws (1), four flat washers (2), and four nuts (3).
2. Remove evaporator motor bracket (4) from chassis (5).

INSTALLATION

1. Install evaporator motor bracket (4) onto chassis (5) with four flat washers (2), and four nuts (3).
2. Refer to WP 0060-00 and attach evaporator motor to evaporator motor bracket (4) and loosely install motor mounting hardware.
3. Refer to WP 0059-00 and install evaporator impeller fans and loosely install fan mounting hardware.
4. Refer to WP 0058-00 and install evaporator fan scrolls and loosely install scroll mounting hardware.
5. Center all components to eliminate contact between all rotating components and then tighten all hardware.
6. Install evaporator fan assembly into unit. Refer to WP 0057-00.

EVAPORATOR MOTOR BRACKET AND CHASSIS DIRECT SUPPORT MAINTENANCE
REPLACEMENT – Continued

0061-00

END OF
TASK

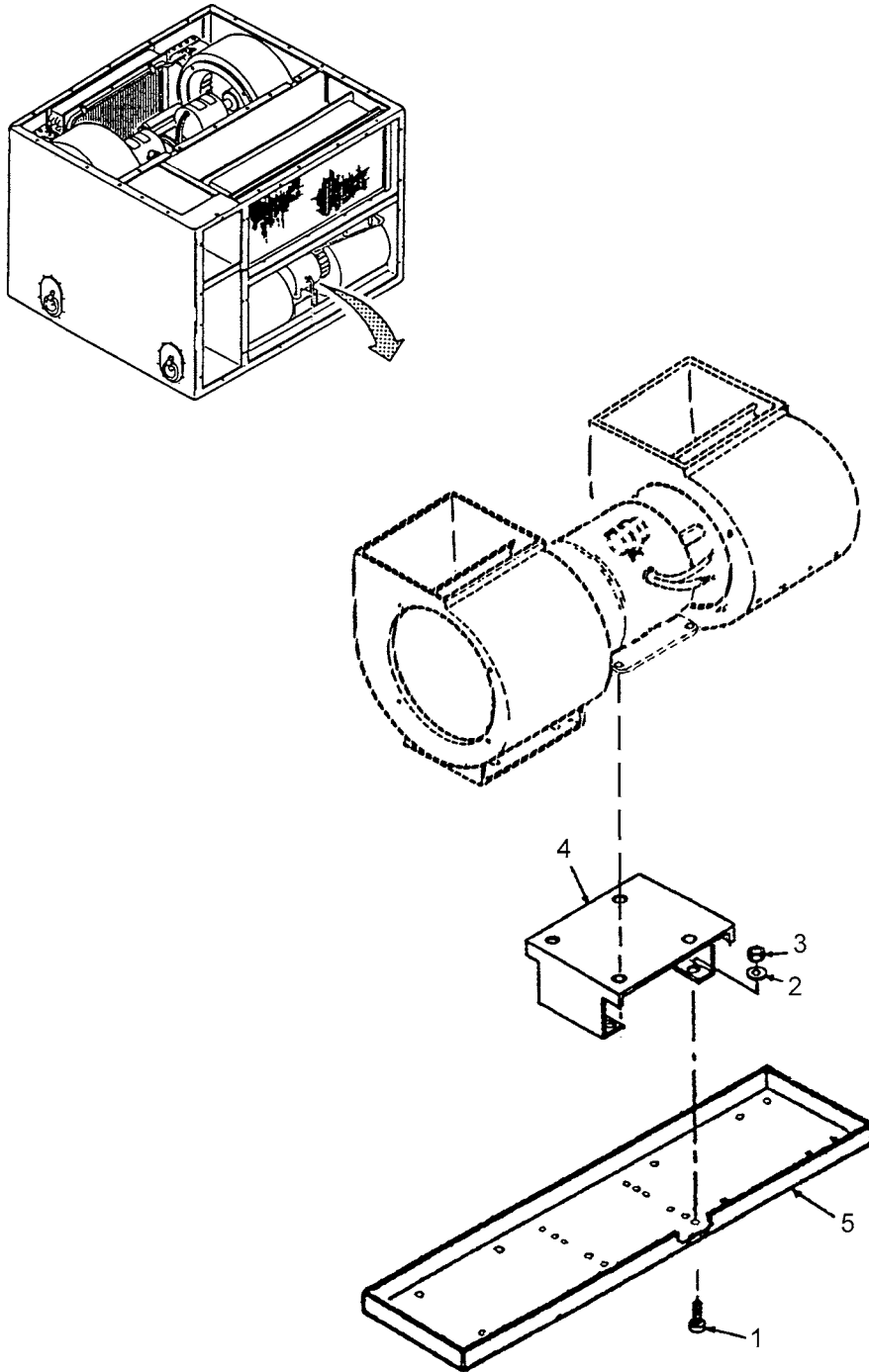

**CONDENSER IMPELLER FANS AND MOTORS DIRECT SUPPORT MAINTENANCE
REPLACEMENT**

0062-00

THIS WORK PACKAGE COVERS:

Removal and Installation

INITIAL SETUP:

Maintenance Level

Direct Support

Tools and Special Tools

Tool Kit, General Mechanics (Item 1, Table 2, WP 0118-00)
Key, Socket Head Screw (Item 13, Table 2, WP 0118-00)

Equipment Condition

Main power source is disconnected, shut down and cool.
Top covers removed (WP 0019-00).

Material

Grease, General Purpose (Item 28, Table 1, WP 0121-00)

References

WP 0031-00 (Condenser fan motor test)

WARNING

Disconnect air conditioner power.

NOTE

The following instructions are for the CCW motor and impeller. Instructions for removal and installation for the CW motor and impeller are the same as for the CCW motor and impeller.

CAUTION

Mismatching motors and fans will cause air conditioner to operate improperly.
Match mark fans and motors to ensure proper re-assembly.

REMOVAL

1. Tag and disconnect all wires from condenser fan motor being replaced.
2. Before removing motor, mark the direction of motor rotation on chassis.
3. Remove four nuts (1) four lockwashers (2), and four flat washers (3) to release motor (4) from motor mounting plate (5).
4. Using a socket head screw key (Item 13, Table 2, WP 0118-00) loosen two setscrews (6) from impeller (7) to release impeller from motor shaft.

**CONDENSER IMPELLER FANS AND MOTORS DIRECT SUPPORT MAINTENANCE
REPLACEMENT - Continued**

0062-00

REMOVAL - Continued

5. Slide out motor shaft from impeller.
6. Lift out motor from unit.
7. Remove four screws (8) and four flat washers (9) to remove inlet bell (10) from scroll (11).
8. Remove impeller (7) from scroll (11).

INSTALLATION**NOTE**

Install condenser motor so that direction of rotation arrow matches rotation mark on chassis.

NOTE

Be sure to coat the motor shaft with general purpose grease (Item 28, Table 1, WP 0121-00) to aid assembly of impeller fan on motor shaft.

1. Use a socket head screw key (Item 13, Table 2, WP 0118-00) to install setscrew (6) onto impeller (7) but leave a loose fit for motor shaft assembly.
2. Position impeller (7) into the scroll (11).
3. Install inlet bell (10) on the scroll (11) using four screws (8) and four flat washers (9).
4. Position motor (4) onto motor mounting plate (5) while sliding motor shaft into impeller (7).
5. Center all parts to eliminate contact between rotating components.
6. Secure motor (4) with four nuts (1), and four washers (2 and 3).
7. Adjust position of impeller and secure with two setscrews (6).
8. Reconnect wiring, remove tags. See schematic diagram WP 0122-00.
9. Install top covers (WP 0019-00).

**CONDENSER IMPELLER FANS AND MOTORS DIRECT SUPPORT MAINTENANCE
REPLACEMENT - Continued**

0062-00

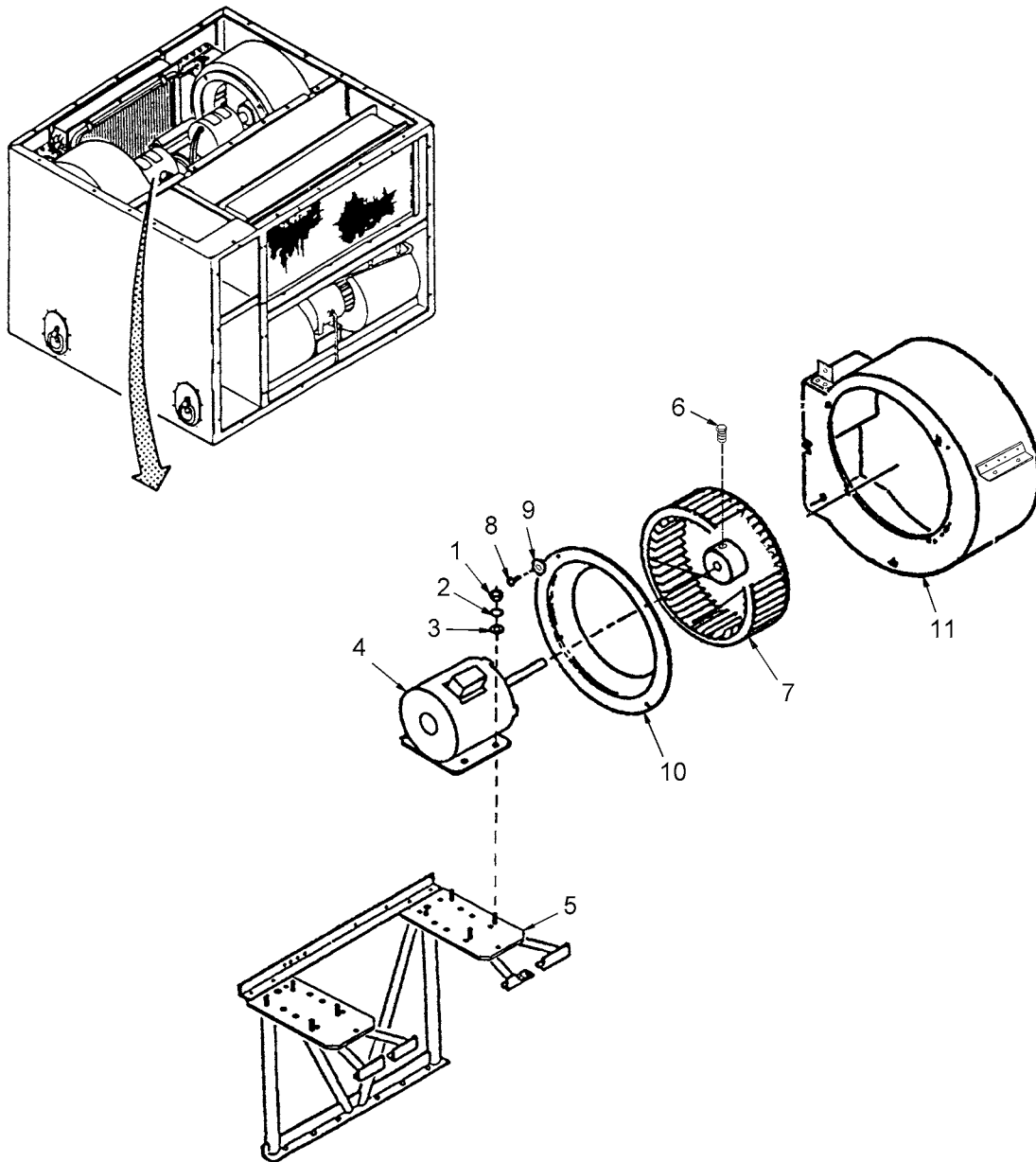

END OF TASK

CONDENSER FAN SCROLLS DIRECT SUPPORT MAINTENANCE REPLACEMENT

0063-00

THIS WORK PACKAGE COVERS:

Removal and Installation

INITIAL SETUP:

Maintenance Level

Direct Support

Tools and Special Tools

Tool Kit, General Mechanics (Item 1, Table 2, WP 0118-00)

Equipment Condition

Main power source is disconnected, shut down and cool.

Top panel removed (WP 0019-00).

Liquid sight indicator mounting hardware removed (WP 0075-00).

Louver actuator cables removed (WP 0032-00).

Condenser fan motors removed (WP 0062-00).

Condenser air discharge louvers removed (WP 0021-00).

Service valve clamps disassembled from scrolls (WP 0073-00).

WARNING

Disconnect air conditioner power input connector.

NOTE

The following are removal and installation instructions for scroll (5). Instructions for scroll (6) are similar except it does not have service valve clamp attachment.

REMOVAL

1. Remove louver actuator cables (1) (figure 1) from unit. Refer to WP 0032-00 for instruction on removal of cables.

NOTE

When performing steps 2 and 3 do not break in the refrigerant system or loosen refrigerant connections.

2. Remove actuator mounting bracket and damper actuator cylinder subassembly (16) from motor mounting brackets (21) and (22) by removing four screws (17) and four lockwashers (18). Carefully move the subassembly (16) away from the motor mounting bracket. See figure 2.
3. Release service valve clamps from left hand scroll (5) and carefully move refrigerant tubing away from condenser fan scroll mounting area. See WP 0073-00.
4. Remove motor mounting bracket (22) by removing two screws (23), two lock washers (24), one screw (25), one screw (26), one lock washer (27), and six screws (28). See figure 2.

**CONDENSER FAN SCROLLS DIRECT SUPPORT MAINTENANCE
REPLACEMENT - Continued**

0063-00

REMOVAL – Continued

5. Remove condenser motor brace (29) from condenser support (32) by removing four screws (30) and four lock washers (31). See figure 2.

NOTE

Mounting parts (screws, washers and brackets) are the same for each scroll (5 and 6).
Disassembly is also the same for each scroll.

6. Remove two screws (2), two flat washers (3), and two grommets (4) from scroll (5). See figure 1.
7. Remove two screws (7), two flat washers (8), two nonmetallic grommets (9), and spacers (10 and 11) to release scroll (5) from scroll support (12). Leave scroll support in place unless damaged, then replace.
8. Carefully move back service valve piping and lift out scroll from unit housing.
9. Repeat for other condenser fan scroll (6) as required.

INSTALLATION

1. If removed, install scroll support (12) with two screws (13), two flat washers (14) and two nuts (15). See figure 1.
2. Position spacers (10 and 11), two grommets (9) and scroll (5) onto scroll support (12) and secure with two screws (7) and two flat washers (8).
3. Install two grommets (4), two flat washers (3) and two screws (2).
4. Install condenser motor brace (29) with four screws (30) and four lockwashers (31). See figure 2.
5. Install motor mounting bracket (22) with two screws (23), two lockwashers (24), one screw (25), one screw (26), one lockwasher (27), and six screws (28).
6. Repeat steps (1 thru 5) for right hand scroll (6). See figure 1.
7. Install actuator mounting bracket and damper actuator cylinder subassembly (16) with four screws (17), and lock washers (18). See figure 2.
8. Install condenser fan motors. See WP 0062-00.
9. Secure service valve clamps to scroll (5). See WP 0073-00.
10. Install louver actuator cables (1). See WP 0032-00.
11. Install liquid sight mounting hardware. See WP 0075-00.
12. Install condenser air discharge louvers. See WP 0021-00.
13. Install top panels. See WP 0019-00.

CONDENSER FAN SCROLLS DIRECT SUPPORT MAINTENANCE
REPLACEMENT - Continued

0063-00

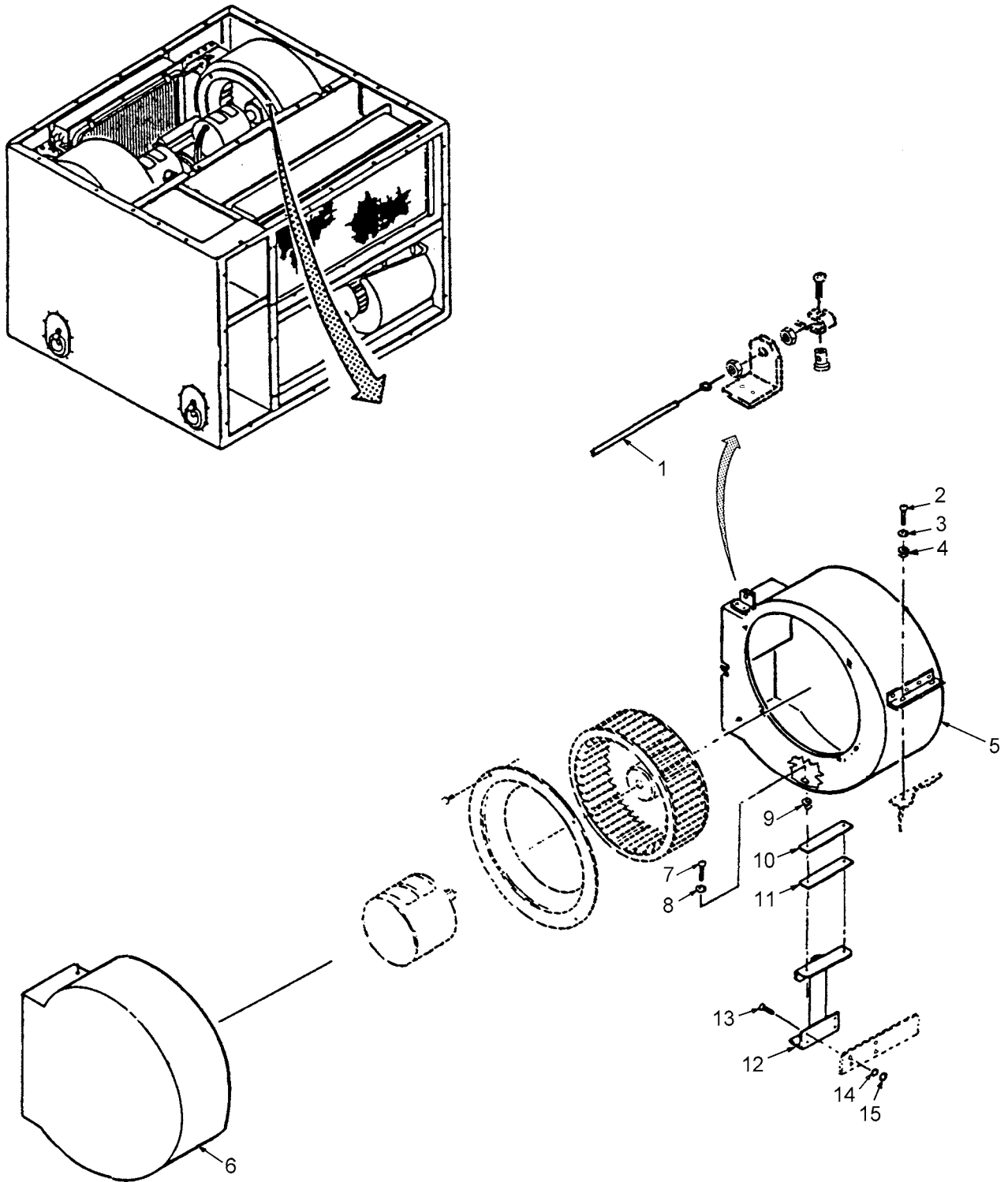

Figure 1. Condenser Scrolls

CONDENSER FAN SCROLLS DIRECT SUPPORT MAINTENANCE
REPLACEMENT - Continued

0063-00

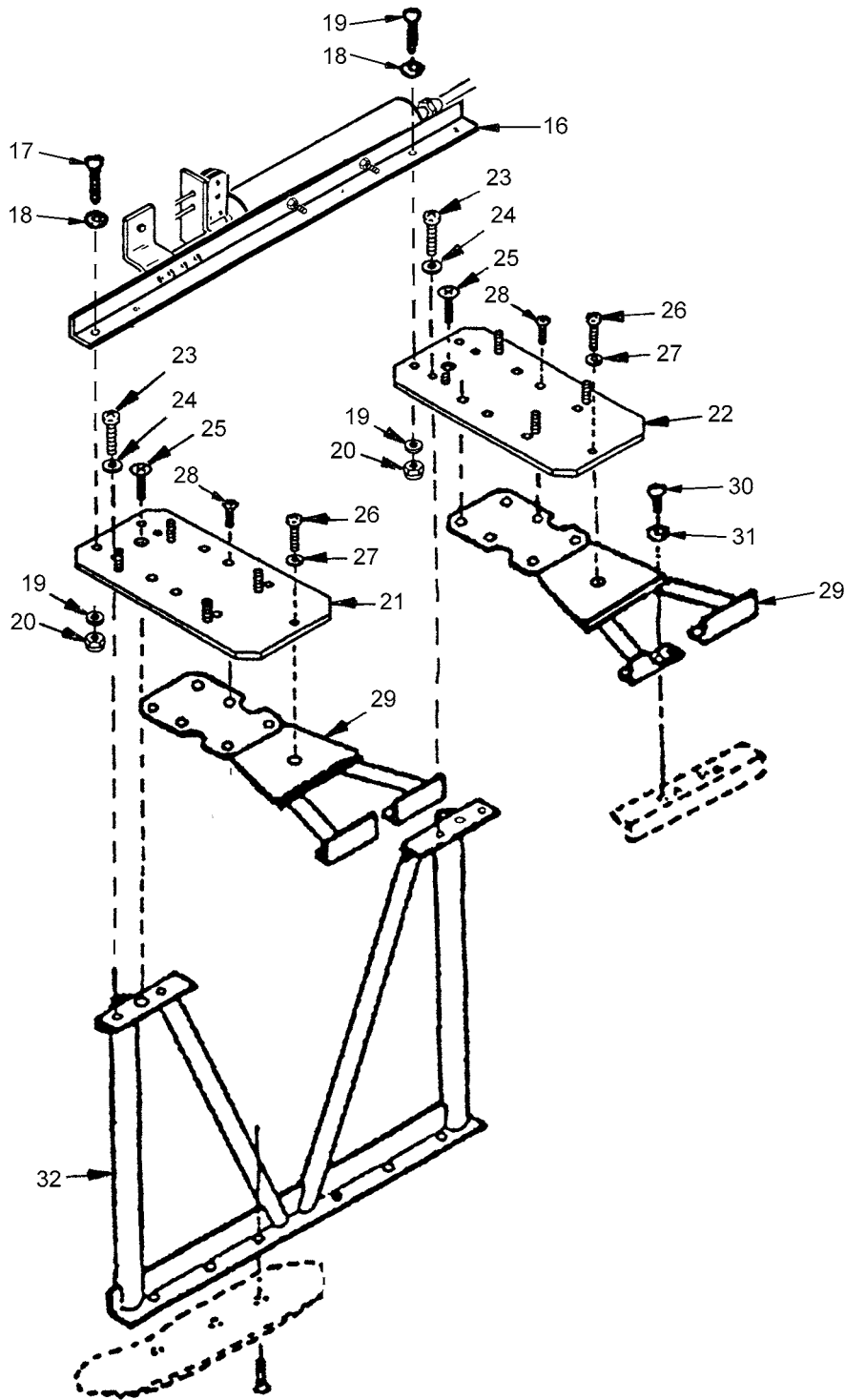

Figure 2. Condenser Fan Motor Mounts, Supports and Brackets

END OF TASK

CONDENSER FAN SUPPORT DIRECT SUPPORT MAINTENANCE REPLACEMENT

0064-00

THIS WORK PACKAGE COVERS:

Removal and Installation

INITIAL SETUP:

Maintenance Level

Direct Support

Tools and Special Tools

Tool Kit, General Mechanics (Item 1, Table 2, WP 0118-00)

Lifting device

Reference

WP 0063-00 Condenser fan scrolls

Equipment Condition

Main power source is disconnected, shut down and cool.

Top panel removed (WP 0019-00).

Liquid sight indicator mounting hardware removed (WP 0075-00).

Louver actuator cables removed (WP 0032-00).

Condenser fan motors removed (WP 0062-00).

Condenser air discharge louvers removed (WP 0021-00).

Condenser scrolls removed (WP 0063-00).

WARNING

Disconnect air conditioner power input connector.

NOTE

For removal and installation, a lifting device must be used to engage the four lifting rings on the sides of the unit to access the condenser fan support screws.

WARNING

Do not allow the unit to swing while suspended from a lifting device. Failure to observe this warning may result in injury to personnel and damage to the equipment.

CAUTION

Use care in handling to avoid damage to the air conditioner. If an overhead lifting device must be used, use an appropriate sling so that the weight of the unit is supported by the base of the shipping container.

**CONDENSER FAN SUPPORT DIRECT SUPPORT MAINTENANCE
REPLACEMENT - Continued**

0064-00

REMOVAL

1. Perform removal of all parts as described in WP 0063-00 condenser fan scrolls and associated parts.
2. Carefully lift air conditioner onto a stand to expose bottom of air conditioner and remove six screws (1) and condenser motor support (2) from the unit housing.

INSTALLATION

1. Using a lifting device carefully lift air conditioner onto a stand to expose bottom of air conditioner and install condenser motor support (2) and six screws (1).
2. Install condenser fan scrolls and all associated parts as described in WP 0063-00.
3. Install damper actuator cylinder. See WP 0068-00.
4. Install condenser fan motor and impeller fans. See WP 0062-00.
5. Secure liquid sight indicator with its mounting hardware. See WP 0075-00.
6. Install air discharge louvers. See WP 0021-00.
7. Install and adjust louver actuator cables. See WP 0032-00.
8. Install top panels. See WP 0019-00.

CONDENSER FAN SUPPORT DIRECT SUPPORT MAINTENANCE
REPLACEMENT - Continued

0064-00

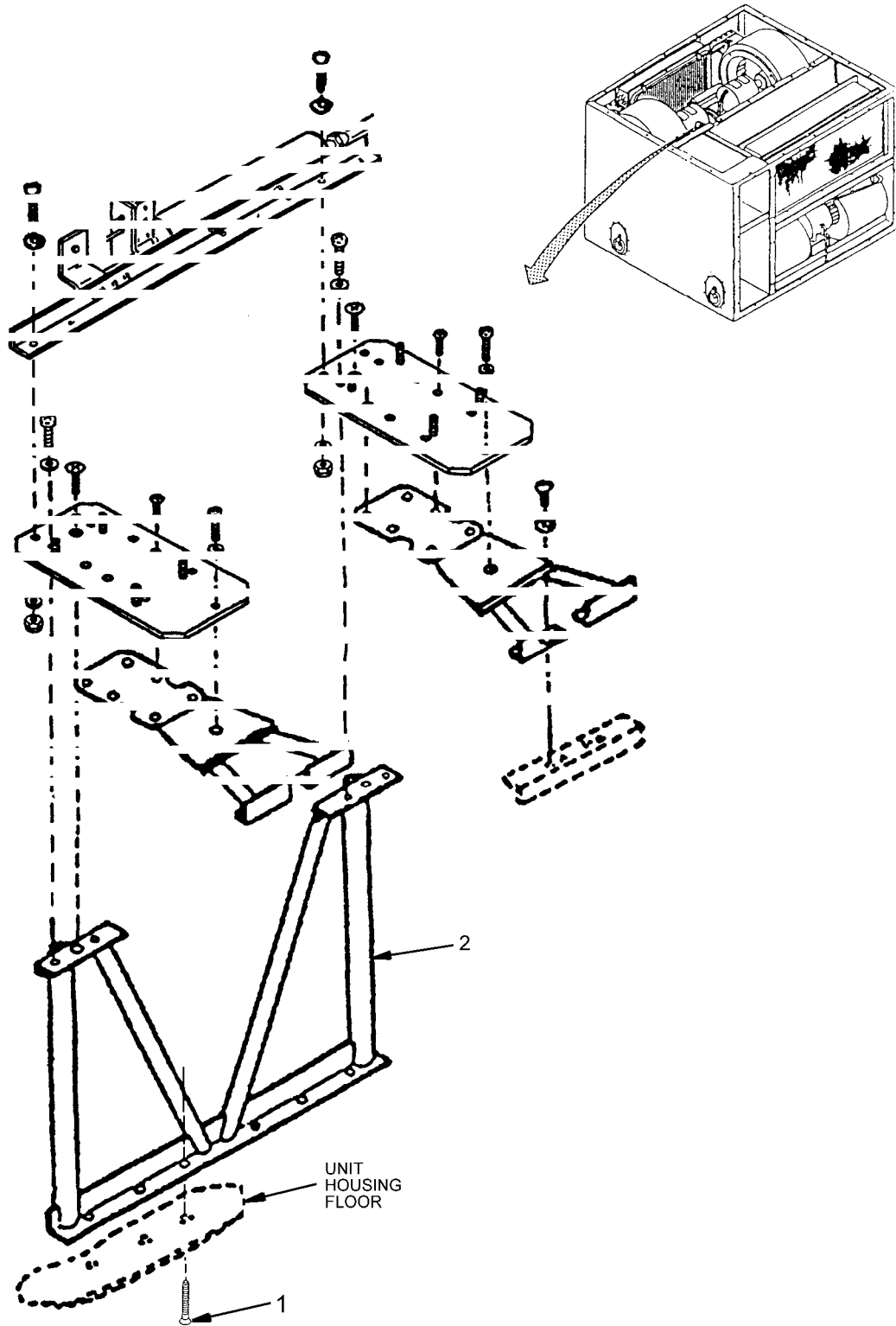

END OF TASK

VENTILATION DAMPER DIRECT SUPPORT MAINTENANCE

0065-00

THIS WORK PACKAGE COVERS:

Removal, Inspection, Cleaning, Repair, Installation, and Test

INITIAL SETUP:

Maintenance Level

Direct

Tools and Special Tools

Tool Kit, General Mechanics (Item 1, WP 0118-00)

Equipment Condition

Top covers removed (WP 0019-00).

Ventilation air filter and guard removed (WP 0022-00).

Condenser air discharge louver – left hand removed (WP 0021-00).

Junction box assembly removed (WP 0036-00).

Condenser fan scroll closest to damper removed (WP 0062-00).

Materials/Parts

Dry cleaning solvent (Item 16, WP 0121-00)

Cloth, lint free (Item 9, WP 0121-00)

WARNING

Disconnect air conditioner power.

REMOVAL

1. Release ventilation damper chain (10) to close damper (21).
2. Remove two screws (5) to release two clamps (9) from side of unit housing.
3. Remove screw (2), washer (3) and nut (4) to release spring (13) from unit housing.
4. Remove two screws (1) to release damper from side of unit housing.
5. Remove the ventilation damper from unit housing.

INSPECTION

1. Inspect ventilation damper parts for bending and warping.
2. Inspect insulation (22) for damage.
3. Inspect spring (13) for sufficient tension.
4. Inspect chain's length to ensure proper action of damper plate.
5. Inspect condition of insulation tubing (8). Replace if necessary.

CLEANING

1. Wipe off dirt with clean lint free cloth, (Item 9, WP 0121-00).

WARNING

Clean parts in a well-ventilated area. Avoid inhalation of solvent fumes and prolonged exposure of skin to cleaning solvent. Wash exposed skin thoroughly. Dry cleaning solvent, P-D-680 Type III, used to clean parts is potentially dangerous to personnel and property. Avoid repeated and prolonged skin contact. Do not use near open flame or excessive heat. Flash point of solvent is 100°F to 138°F (38°C to 59°C).

REPAIR

1. Straighten damper plate (21) and hinge (16) if bent or warped. Replace if necessary.
2. Replace damaged insulation (22).
3. Replace spring (13) if has loose tension.
4. Replace chain (10) if too short.
5. Replace damaged sleeving (8).

INSTALLATION

1. After replacing defective parts, place ventilation damper into unit housing.
2. Install two screws (1) to secure ventilation damper to side of unit housing.
3. Install screw (2), washer (3) and nut (4) to secure spring (13) to unit housing.
4. Install clamps (9) with two screws (5) to unit housing.

TEST

1. Position ventilation damper actuator chain (10) to fully closed position.
2. Shine flashlight into fresh air damper screen side of unit while looking into vent housing from compartment. Ensure no light can be seen around edges of damper insulation seal. If fails, service or replace ventilation damper as necessary.
3. Install condenser fan scrolls (See WP 0062-00).
4. Install condenser fan air discharge louver (See WP 0021-00).
5. Install condenser fan ventilation air filter and guard (See WP 0022-00).
6. Install condenser fan junction box assembly (See WP 0036-00).
7. Install condenser fan top covers (See WP 0019-00).

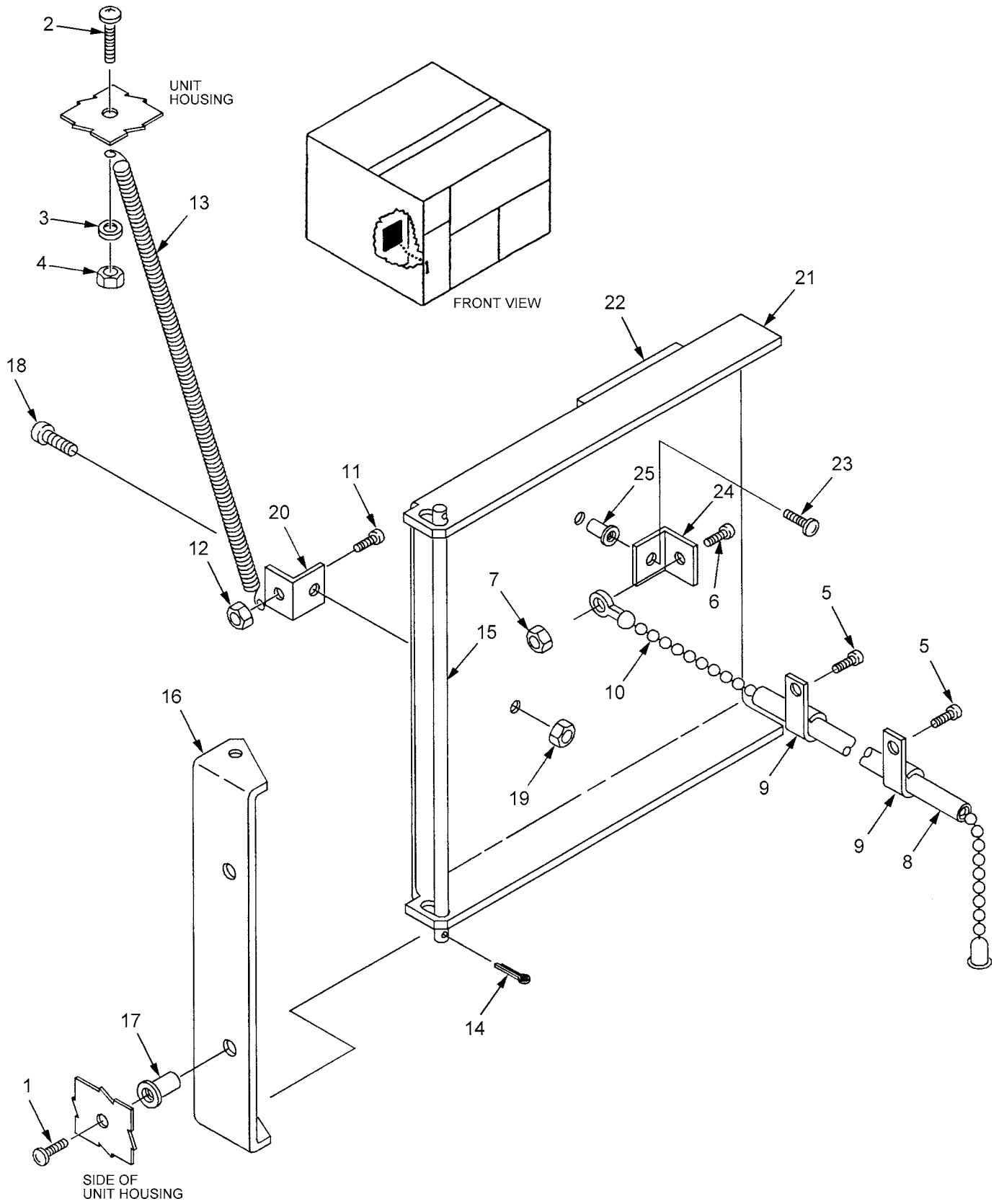

END OF TASK

FILTER-DRIER DIRECT SUPPORT MAINTENANCE REPLACEMENT

0066-00

THIS WORK PACKAGE COVERS:

Inspect, Removal, and Installation

INITIAL SETUP:

Maintenance Level

Direct Support

Tools and Special Tools

Tool Kit, General Mechanics (Item 1, Table 2, WP 0118-00)

Tool Kit, Service, Refrigeration Unit (Item 2, Table 2, WP 0118-00)

Recovery and Recycle Unit, Refrigerant, (Item 5, Table 2, WP 0118-00)

Mask, Air Filtering (Item 29, Table 1, WP 0121-00)

References

WP 0118-00 (MAC)

Equipment Condition

Mode selector switch in OFF position.

Main power source is disconnected.

System refrigerant discharged (WP 0049-00).

Test Equipment

Electronic refrigerant gas leak detector

Materials/Parts

Nitrogen (Item 4, Table 1, WP 0121-00)

Special Environmental Condition

NOTE

In accordance with Environmental Protection Agency regulations, refrigerants cannot be discharged into the atmosphere. A refrigerant recovery and recycling unit must be used whenever discharging the refrigerant system.

Operation of the recovery/recycling unit must be by AUTHORIZED PERSONNEL ONLY.

INSPECT

Check filter-drier for leaks or damage.

NOTE

The filter-drier must be replaced each time the refrigeration system has been opened. It should be installed just before unit is leak tested.

FILTER-DRIER LOCATION

The filter-drier is located on the top center wall of the housing.

REMOVAL**WARNING**

Check that power source is disconnected. Check that refrigerant system is discharged.

1. Unscrew flare nuts (2) and remove refrigerant lines (5) from filter-drier (1).
2. Remove screw (3) and strap (4).
3. Remove filter-drier (1).

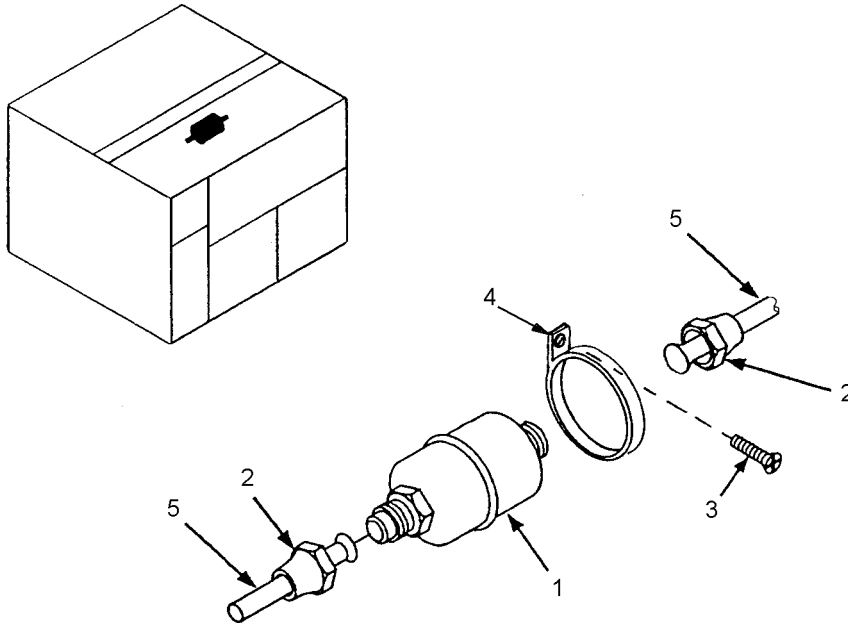
**INSTALLATION****CAUTION**

Replacement filter-drier are packaged with sealing caps on the flare fittings to prevent moisture contamination of the desiccant filtering media. Remove these caps immediately prior to installation. Never install a filter-drier from which caps have been removed for an extended or unknown period of time.

1. Check the direction arrow marked on the filter-drier (1).
2. Position filter-drier (1) between refrigerant lines (5).
3. Tighten flare nuts (2).
4. Install strap (4) with screw (3).
5. Leak test refrigerant system (See WP 0052-00).

INSTALLATION – Continued

6. Evacuate refrigerant system (See WP 0053-00).
7. Charge refrigerant system (See WP 0054-00).
8. Install top panels (See WP 0019-00).

END OF TASK

**SOLENOID VALVES AND HOT GAS BY-PASS VALVE
DIRECT SUPPORT MAINTENANCE REPLACEMENT**

0067-00

THIS WORK PACKAGE COVERS:

Test, Removal, and Installation

INITIAL SETUP:

Maintenance Level

Direct Support

Tools and Special Tools

Tool Kit, General Mechanics (Item 1, Table 2, WP 0118-00)
Tool Kit, Service, Refrigeration Unit (Item 2, Table 2, WP 0118-00)
Recovery and Recycle Unit, Refrigerant, (Item 5, Table 2, WP 0118-00)
Mask, Air Filtering (Item 29, Table 1, WP 0121-00)

References

WP 0118-00 (MAC)
WP 0039-00 (Coil Replacement)

Equipment Condition

Mode selector switch in OFF position.
Main power source is disconnected.
Top rear panel removed (WP 0019-00).
Condenser fan motor nearest hot gas by-pass valve removed (See WP 0031-00).
Condenser fan scroll and bracket nearest hot gas by-pass valve removed (See WP 0062-00).
Recover refrigerant from system (See WP 0049-00).
System purged with nitrogen (See WP 0050-00).
Debraze related tube connections (See WP 0079-00 and WP 0051-00).

Test Equipment

Electronic refrigerant gas leak detector

Materials/Parts

Nitrogen (Item 4, Table 1, WP 0121-00)
Braze alloy (Item 5 or 6, Table 1, WP 0121-00)
Braze flux (Item 7, Table 1, WP 0121-00)

Special Environmental Condition

NOTE

In accordance with Environmental Protection Agency regulations, refrigerants cannot be discharged into the atmosphere. A refrigerant recovery and recycling unit must be used whenever discharging the refrigerant system.

Operation of the recovery/recycling unit must be by AUTHORIZED PERSONNEL ONLY.

**SOLENOID VALVES AND HOT GAS BY-PASS VALVE
DIRECT SUPPORT MAINTENANCE REPLACEMENT – Continued**

0067-00

SOLENOID VALVES AND HOT GAS BY-PASS VALVE**TEST****Equalization Solenoid Valve (3)****NOTE**

This is a test for valve operation and the equalization of discharge and suction refrigerant pressure when compressor is shut off. When compressor is operating, valve should be energized and closed. This is a normally open valve.

1. Connect service gauges to service valves and observe pressures with system operating in the “cooling mode” with unit delivering cold air.
2. Turn selector switch to “OFF” and observe system refrigerant pressures.
3. Refrigerant pressures (suction and discharge) should equalize immediately and be at same pressure within 5 seconds.
4. Remove top rear panel (See WP 0019-00) and operate unit in “cooling mode” with unit delivering cold air for no more than 2 minutes at a time.
5. Observe temperature (by touch) of valve outlet tubing.
6. Tubing temperature at valve outlet should be at approximately room temperature (NOT HOT).
7. With unit operating as in step 4, and if tubing temperature in step 6 is hot, check solenoid coil by removing the solenoid coil to feel the magnetic attraction of the coil to the valve.
8. If there is no magnetic attraction of coil to valve, the problem is electrical and not the solenoid valve.
9. If observation in step 3 and step 6 are not as stated, solenoid valve is defective and must be replaced.

Liquid Line Solenoid Valve (1)**NOTE**

This is a test for valve operation. The valve functions in “cooling mode” to control cooling output of unit by supplying liquid refrigerant to the cooling coil (evaporator).

1. Operate the unit in “cooling mode” and observe (evaporator) supply air temperature.
2. With temperature selector in “coolest” position the supply air temperature should be cold (approximately 15°F below ambient).
3. With the temperature selector in “warmest” position, the supply air temperature should be same as ambient temperature or 1 or 2 degrees warmer.
4. When the unit is operating as in step 2 above, but with supply air temperature not cold, remove top rear panel (See WP 0019-00) and check solenoid coil by removing the solenoid coil to feel the magnetic attraction of the coil to the valve.

**SOLENOID VALVES AND HOT GAS BY-PASS VALVE
DIRECT SUPPORT MAINTENANCE REPLACEMENT – Continued**

0067-00

TEST- Continued**Liquid Line Solenoid Valve (1) - Continued**

5. If no magnetic attraction of coil to valve, problem is electrical and not the solenoid valve.
6. If observations in step 2 and step 3 are not as stated, solenoid valve is defective and must be replaced.

Hot Gas By-Pass Valve (5)**NOTE**

This is a test for valve operation and the maintenance of suction refrigerant pressure above 50 psig (freezing temperature) to prevent evaporator coil freeze-up.

1. Connect service gauges to service valves and observe system pressure when operating in the “cooling mode” with temperature selector switch in the coolest position.
2. Block indoor air return and note refrigerant suction pressure reading.
3. Suction pressure should be above 55 psig under normal operation and blocked indoor air return conditions.
4. If suction pressure is above 55 psig under normal operation and below 55 psig under blocked indoor air return condition, adjust the valve as follows:
 - a. Remove top rear cover and large valve cap on top of valve to expose adjustment stem. Turn adjustment stem clockwise until suction pressure is above 55 psig.
 - b. If adjustment does not result in the suction pressure above 55 psig, valve is defective and must be replaced.

WARNING

Ensure power source is disconnected. Ensure refrigerant system is discharged.

REMOVAL

1. Tag and disconnect coil wires. Remove coils (2 and 4) (See WP 0039-00).

NOTE

Solenoid coil (2) is a 24 V ac coil. Solenoid coil (4) is a 208 V ac coil.

2. Debraze all tubing connected to valves (1), (3) or (5) (See WP 0051-00).
3. Remove valves from unit.

INSTALLATION

1. After noting arrow direction on each valve body, place tubing connections (6) onto valves (1), (3) or (5).
2. Braze the tube joints (See WP 0051-00).

**SOLENOID VALVES AND HOT GAS BY-PASS VALVE
DIRECT SUPPORT MAINTENANCE REPLACEMENT – Continued**

0067-00

INSTALLATION - Continued

3. Install solenoid coils (2 and 4) and reconnect wiring (See WP 0039-00).
4. After noting arrow direction on filter-drier body replace filter-drier (See WP 0066-00).
5. Replace condenser fan scroll (See WP 0062-00).
6. Replace condenser fan motor (See WP 0031-00).
7. Install top rear panel (See WP 0019-00).
8. Service the refrigeration system (See WP 0049-00 thru WP 0055-00).

SOLENOID VALVES AND HOT GAS BY-PASS VALVE
DIRECT SUPPORT MAINTENANCE REPLACEMENT – Continued

0067-00

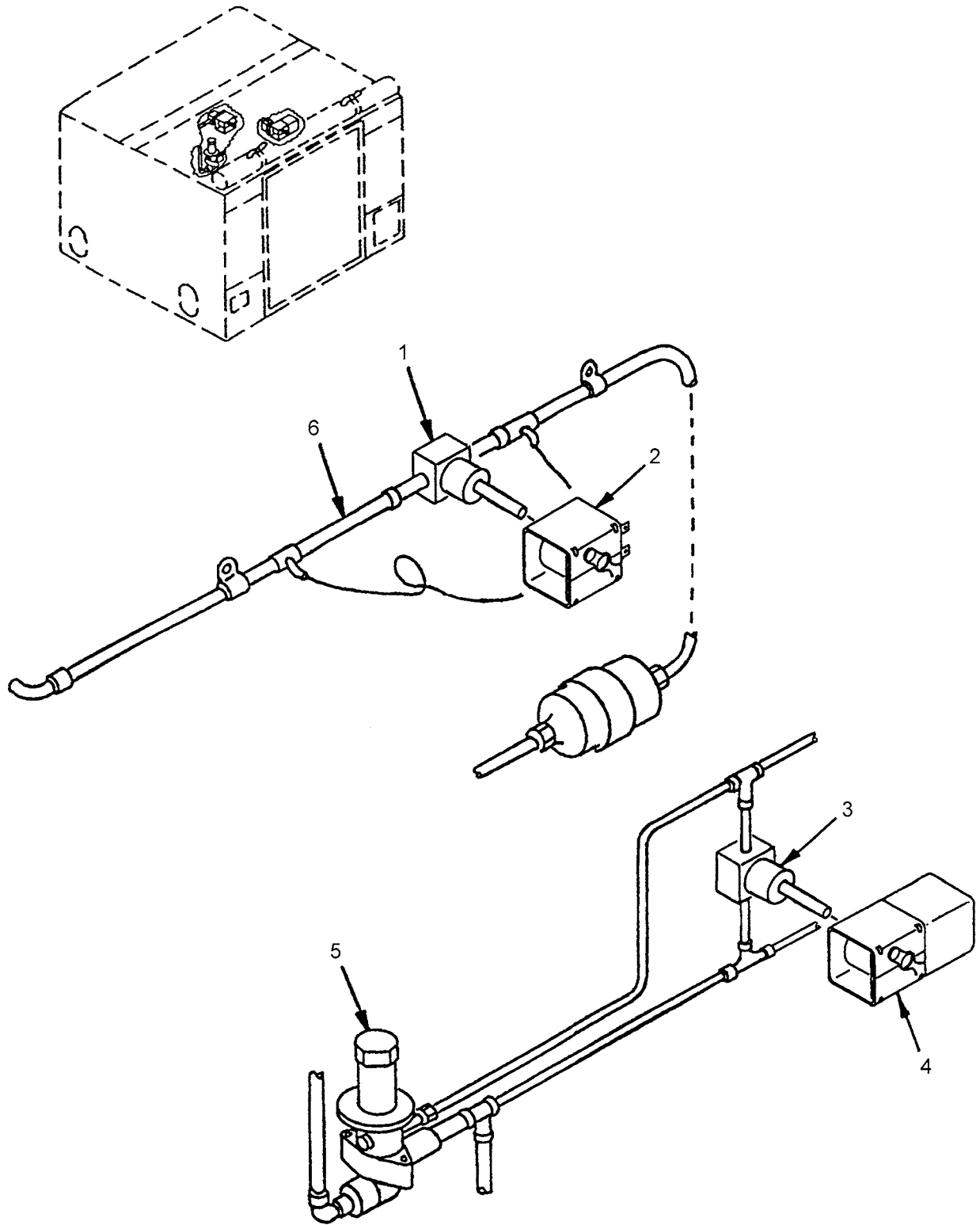

END OF TASK

DAMPER ACTUATOR CYLINDER DIRECT SUPPORT MAINTENANCE REPLACEMENT

0068-00

THIS WORK PACKAGE COVERS:

Removal, and Installation

INITIAL SETUP:

Maintenance Level

Direct Support

Tools and Special Tools

Tool Kit, General Mechanics (Item 1, Table 2, WP 0118-00)

Tool Kit, Service, Refrigeration Unit (Item 2, Table 2, WP 0118-00)

Recovery and Recycle Unit, Refrigerant, (Item 5, Table 2, WP 0118-00)

Mask, Air Filtering (Item 29, Table 1, WP 0121-00)

References

WP 0118-00 (MAC)

Equipment Condition

Mode selector switch in OFF position.

Main power source is disconnected.

Top rear panel removed (WP 0019-00).

System refrigerant discharged (WP 0049-00).

Test Equipment

Electronic refrigerant gas leak detector

Materials/Parts

Nitrogen (Item 4, Table 1, WP 0121-00)

Lubricating oil (Item 14, Table 1, WP 0121-00)

Special Environmental Condition

NOTE

In accordance with Environmental Protection Agency regulations, refrigerants cannot be discharged into the atmosphere. A refrigerant recovery and recycling unit must be used whenever discharging the refrigerant system.

Operation of the recovery/recycling unit must be by AUTHORIZED PERSONNEL ONLY.

**DAMPER ACTUATOR CYLINDER
DIRECT SUPPORT MAINTENANCE REPLACEMENT - Continued**

0068-00

WARNING

Ensure power source is disconnected. Ensure refrigerant system is discharged.

REMOVAL

1. Loosen flare nut (1) on damper actuator cylinder (2).
2. Remove two mechanical posts (3) and screws (4) from control assembly cables (5) and (6).
3. Remove two nuts (7), two lockwashers (8) that secure the damper actuator cylinder (2) to angle (9).
4. Remove damper actuator cylinder (2) from unit.

INSTALLATION

1. Install damper actuator cylinder (2) to angle (9) with two lockwashers (8) and two nuts (7).
2. Install control assembly cable (5), control assembly cable (6), and two mechanical posts (3) with screws (4).
3. Apply oil to threads of damper actuator cylinder (2) and secure flare nut (1) to damper actuator cylinder.
4. Replace filter- dryer (See WP 0066-00).
5. Adjust damper actuator mechanism (See WP 0032-00).
6. Replace top rear panel (See WP 0019-00).
7. Service refrigeration system (See WP 0049-00 thru WP 0055-00).

DAMPER ACTUATOR CYLINDER
DIRECT SUPPORT MAINTENANCE REPLACEMENT - Continued

0068-00

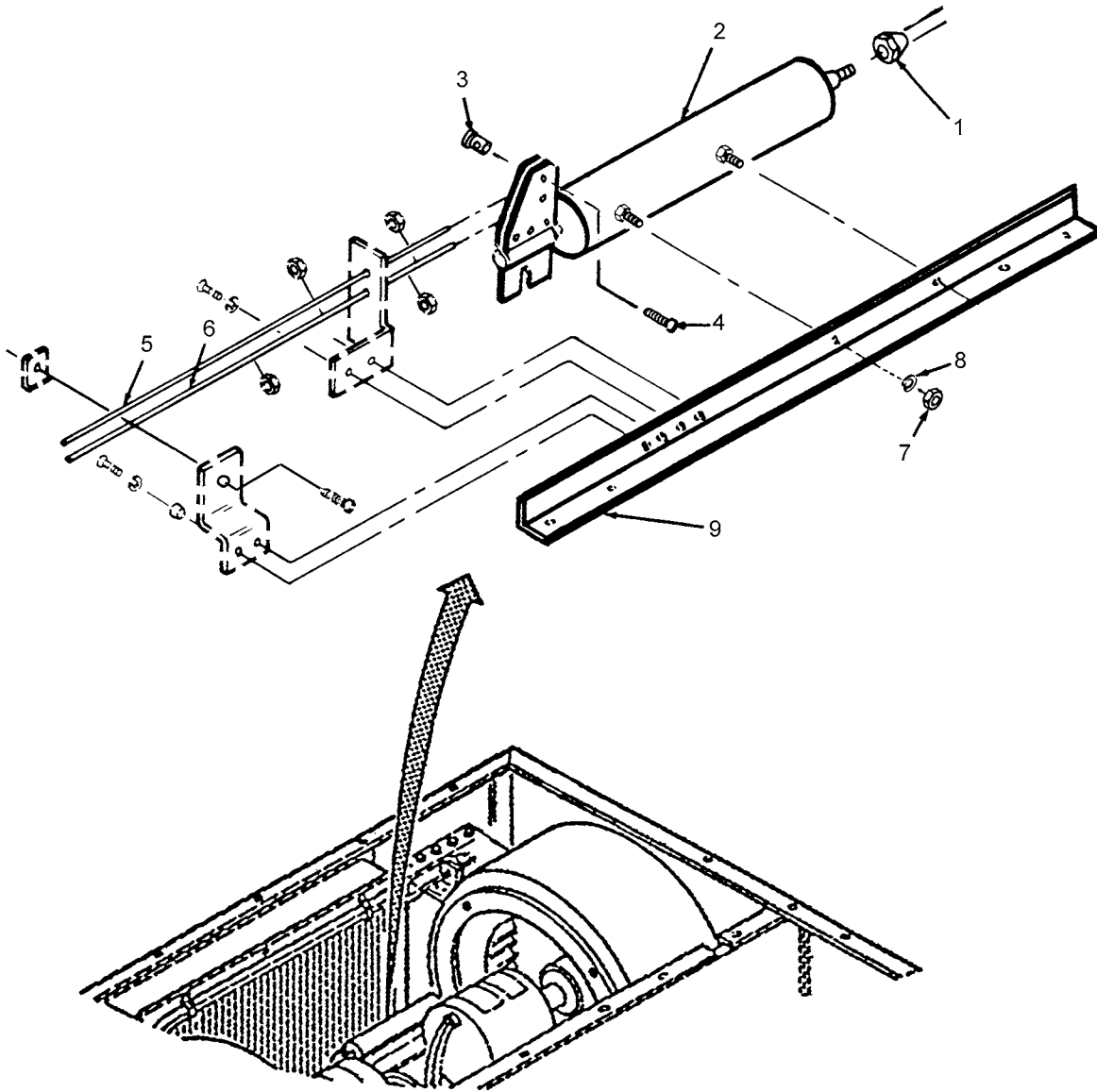

END OF TASK

RECEIVER DIRECT SUPPORT MAINTENANCE REPLACEMENT

0069-00

THIS WORK PACKAGE COVERS:

Removal, and Installation

INITIAL SETUP:

Maintenance Level

Direct Support

Tools and Special Tools

Tool Kit, General Mechanics (Item 1, Table 2, WP 0118-00)

Tool Kit, Service, Refrigeration Unit (Item 2, Table 2, WP 0118-00)

Recovery and Recycle Unit, Refrigerant, (Item 5, Table 2, WP 0118-00)

Mask, Air Filtering (Item 29, Table 1, WP 0121-00)

References

WP 0118-00 (MAC)

Equipment Condition

Mode selector switch in OFF position.

Main power source is disconnected.

Top rear panel removed (WP 0019-00).

Condenser fan motor nearest receiver removed (See WP 0031-00).

Condenser fan scroll and bracket nearest receiver removed (See WP 0062-00).

Recover refrigerant from system (See WP 0049-00).

System purged with nitrogen (See WP 0050-00).

Debraze related tube connections (See WP 0079-00 and WP 0051-00).

Test Equipment

Electronic refrigerant gas leak detector

Materials/Parts

Nitrogen (Item 4, Table 1, WP 0121-00)

Brazing alloy (Item 5 or 6, Table 1, WP 0121-00)

Brazing flux (Item 7, Table 1, WP 0121-00)

Special Environmental Condition

NOTE

In accordance with Environmental Protection Agency regulations, refrigerants cannot be discharged into the atmosphere. A refrigerant recovery and recycling unit must be used whenever discharging the refrigerant system.

Operation of the recovery/recycling unit must be by AUTHORIZED PERSONNEL ONLY.

WARNING

Ensure power source is disconnected. Ensure refrigerant system is discharged.

REMOVAL

1. Remove four screws (1), four lock washers (2), and receiver clamp (3) and (4) which hold receiver (5) onto bracket (9).
2. Remove receiver (5) from unit.
3. Bracket (9) remains in place.

INSTALLATION

1. Place receiver (5) into unit and loosely install receiver clamp (3) and (4) with four lock washers (2), and four screws (1).
2. Place tubing connections (10) onto receiver (5).
3. Braze the tube joints (See WP 0051-00).
4. Tighten hardware installed in step (1).
5. Replace filter drier (See WP 0066-00).
6. Replace condenser fan scroll (See WP 0062-00).
7. Replace condenser fan motor (See WP 0031-00).
8. Install top rear panel (See WP 0019-00).
9. Service the refrigeration system (See WP 0049-00 thru WP 0055-00).

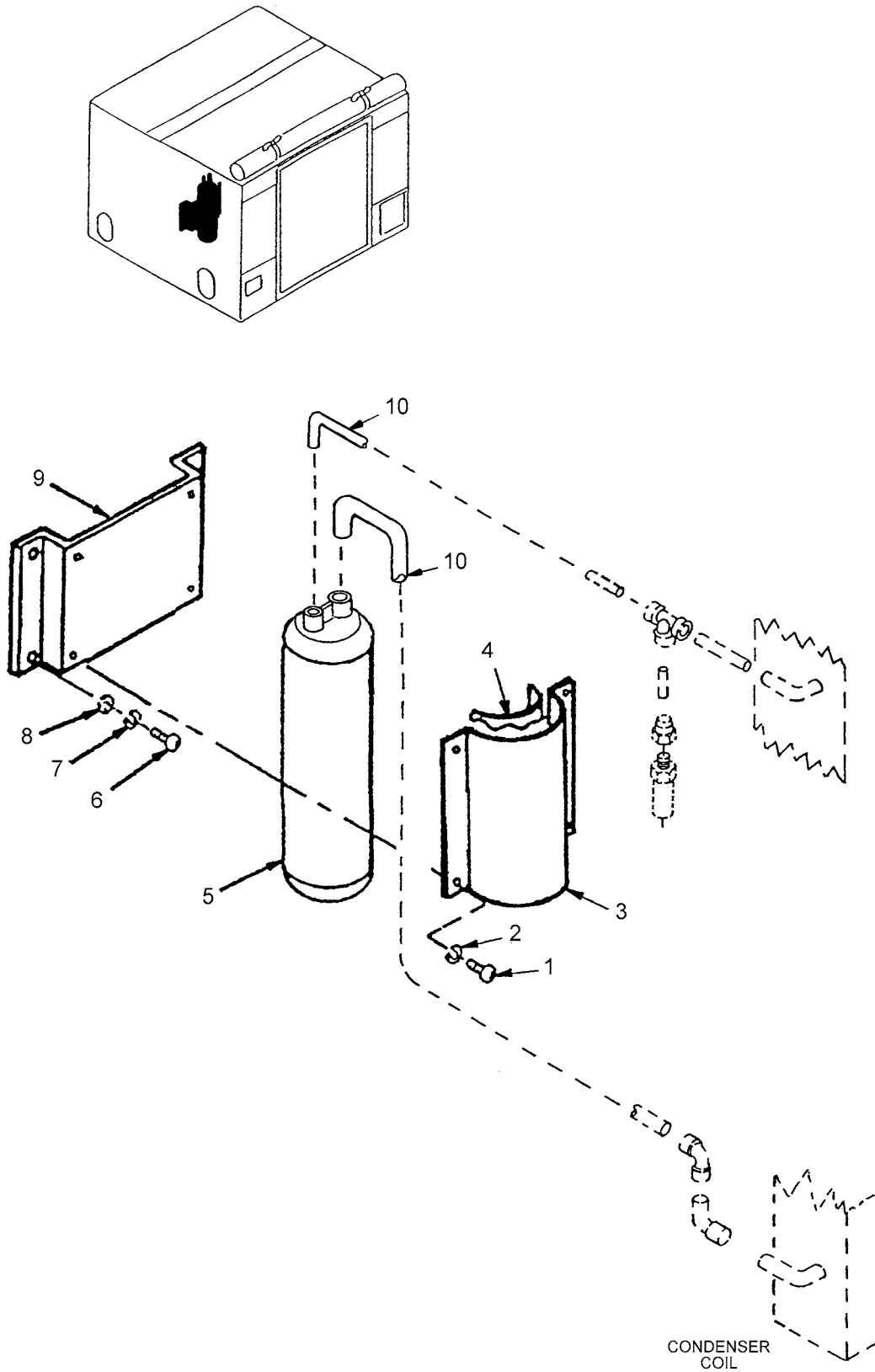

END OF TASK

**PRESSURE RELIEF VALVE
DIRECT SUPPORT MAINTENANCE REPLACEMENT**

0070-00

THIS WORK PACKAGE COVERS:

Removal, and Installation

INITIAL SETUP:

Maintenance Level

Direct Support

Tools and Special Tools

Tool Kit, General Mechanics (Item 1, Table 2, WP 0118-00)

Tool Kit, Service, Refrigeration Unit (Item 2, Table 2, WP 0118-00)

Recovery and Recycle Unit, Refrigerant, (Item 5, Table 2, WP 0118-00)

Mask, Air Filtering (Item 29, Table 1, WP 0121-00)

References

WP 0118-00 (MAC)

Equipment Condition

Mode selector switch in OFF position.

Main power source is disconnected.

Top rear panel removed (WP 0019-00).

Recover refrigerant from system (See WP 0049-00).

Test Equipment

Electronic refrigerant gas leak detector

Materials/Parts

Lubricating oil (Item 14, Table 1, WP 0121-00)

Special Environmental Condition

NOTE

In accordance with Environmental Protection Agency regulations, refrigerants cannot be discharged into the atmosphere. A refrigerant recovery and recycling unit must be used whenever discharging the refrigerant system.

Operation of the recovery/recycling unit must be by AUTHORIZED PERSONNEL ONLY.

**PRESSURE RELIEF VALVE
DIRECT SUPPORT MAINTENANCE REPLACEMENT – Continued**

0070-00

WARNING

Check that power source is disconnected. Check that system is discharged of refrigerant.

INSPECT

Check valve and tubing for damage.

REMOVAL

Unscrew valve (1) from adapter (2) to remove valve from unit.

INSTALLATION

1. Apply lubricating oil (Item 14, Table 1, WP 0121-00) to valve threads and install pressure relief valve (1) in adapter (2).
2. Replace filter-drier (See WP 0066-00).
3. Leak test refrigeration system (See WP 0052-00).
4. Evacuate refrigeration system (See WP 0053-00).
5. Charge refrigeration system (See WP 0054-00).
6. Install rear top panel (See WP 0019-00).

**PRESSURE RELIEF VALVE
DIRECT SUPPORT MAINTENANCE REPLACEMENT – Continued**

0070-00

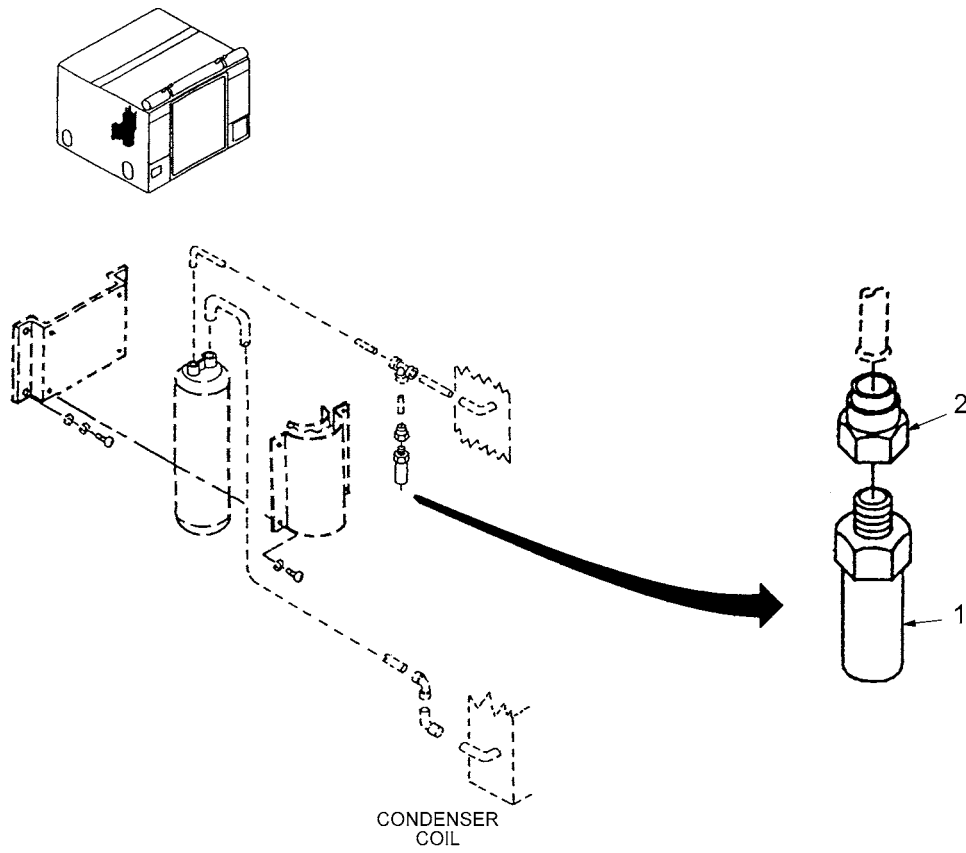

END OF TASK

ACCUMULATOR DIRECT SUPPORT MAINTENANCE REPLACEMENT

0071-00

THIS WORK PACKAGE COVERS:

Removal, and Installation

INITIAL SETUP:

Maintenance Level

Direct Support

Tools and Special Tools

Tool Kit, General Mechanics (Item 1, Table 2, WP 0118-00)

Tool Kit, Service, Refrigeration Unit (Item 2, Table 2, WP 0118-00)

Recovery and Recycle Unit, Refrigerant, (Item 5, Table 2, WP 0118-00)

Mask, Air Filtering (Item 29, Table 1, WP 0121-00)

References

WP 0118-00 (MAC)

Equipment Condition

Mode selector switch in OFF position.

Main power source is disconnected.

Top rear panel removed (WP 0019-00).

Condenser fan motor nearest accumulator removed (See WP 0031-00).

Condenser fan scroll nearest accumulator removed (See WP 0062-00).

Recover refrigerant from system (See WP 0049-00).

System purged with nitrogen (See WP 0050-00).

Test Equipment

Electronic refrigerant gas leak detector

Materials/Parts

Nitrogen (Item 4, Table 1, WP 0121-00)

Brazing alloy (Item 5 or 6, Table 1, WP 0121-00)

Brazing flux (Item 7, Table 1, WP 0121-00)

Tape, insulation

Special Environmental Condition

NOTE

In accordance with Environmental Protection Agency regulations, refrigerants cannot be discharged into the atmosphere. A refrigerant recovery and recycling unit must be used whenever discharging the refrigerant system.

Operation of the recovery/recycling unit must be by AUTHORIZED PERSONNEL ONLY.

WARNING

Ensure power source is disconnected. Ensure refrigerant system is discharged.

REMOVAL

1. Remove insulation and adjacent wrapping sufficient to debraze tube connections.
2. Debraze tubes connected to accumulator (3) (See WP 0051-00).
3. Remove nut (1), flat washer (2), accumulator (1) from bracket (5).
4. Bracket (5) can remain in place unless damaged.

NOTE

Observe direction of flow indicated on accumulator and install it to match flow direction.

INSTALLATION

1. Place accumulator (3) on bracket (5).
2. Install nut (1) and flat washer (2) onto stud of accumulator (3).
3. Braze the tube connections (See WP 0051-00).
4. Replace the filter-drier (See WP 0066-00).
5. Install insulation on accumulator (3) and tubing.
6. Install condenser fan scroll (See WP 0062-00).
7. Install condenser fan motor (See WP 0031-00).
8. Install top rear panel (See WP 0019-00).
9. Service the refrigeration system (See WP 0049 thru WP 0055-00).

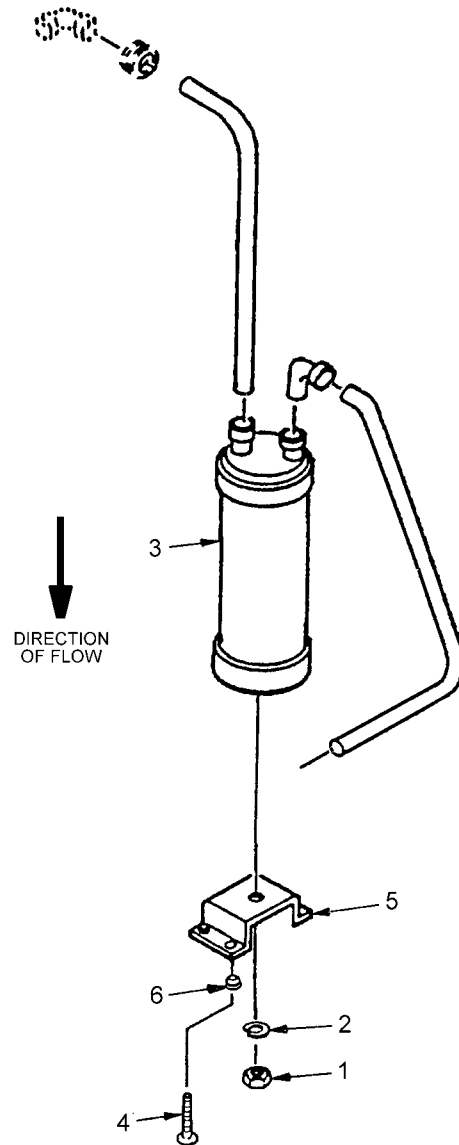
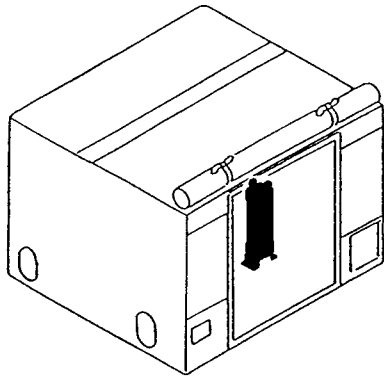

END OF TASK

PRESSURE SWITCHES DIRECT SUPPORT MAINTENANCE REPLACEMENT

0072-00

THIS WORK PACKAGE COVERS:

Inspect, Removal, Test, and Installation

INITIAL SETUP:

Maintenance Level

Direct Support

Tools and Special Tools

Tool Kit, General Mechanics (Item 1, Table 2, WP 0118-00)

Tool Kit, Service, Refrigeration Unit (Item 2, Table 2, WP 0118-00)

Recovery and Recycle Unit, Refrigerant, (Item 5, Table 2, WP 0118-00)

Mask, Air Filtering (Item 29, Table 1, WP 0121-00)

References

WP 0118-00 (MAC)

Equipment Condition

Mode selector switch in OFF position.

Main power source is disconnected.

System refrigerant discharged (WP 0049-00).

Top panels removed (WP 0019-00).

Remote control module removed and circuit breaker panel removed (WP 0033-00 and WP 0034-00).

Test Equipment

Multimeter

Electronic refrigerant gas leak detector

Materials/Parts

Nitrogen (Item 4, Table 1, WP 0121-00)

Special Environmental Condition

NOTE

In accordance with Environmental Protection Agency regulations, refrigerants cannot be discharged into the atmosphere. A refrigerant recovery and recycling unit must be used whenever discharging the refrigerant system.

Operation of the recovery/recycling unit must be by AUTHORIZED PERSONNEL ONLY.

WARNING

Check that power source is disconnected. Check that refrigerant system is discharged of refrigerant.

INSPECT**Front of Housing**

Check wiring and sensing tube for damage.

REMOVAL

1. Remove two mounting screws (1) and two lockwashers (2) from bracket (3).
2. Remove four screws (4) and four lockwashers (5) to remove switches (6 and 7) from bracket.
3. Unhook the electrical leads from the pressure switches. Tag leads for identification at assembly.
4. Unscrew flare nuts (8) from capillary tube connections (9). Carefully pull capillary tubes (11) through housing partition (10).
5. Remove pressure switches (6 and 7).

TEST

1. Test for continuity across terminals of high pressure switch (6). If no continuity exists, press the reset button and retest.
2. If the switch does not indicate continuity, replace.
3. Using nitrogen, pressurize low pressure cutout switch (15-20 psig range/1.05-1.40 kg/cm² range).
4. Check for continuity across terminals.
5. If continuity does not exist, replace defective switch.
6. Using nitrogen, pressurize high pressure cutout switch (470-490 psig range/33.04-34.45 kg/cm² range).
7. Check for continuity across terminals.
8. If continuity exists, replace defective pressure switch.

INSTALLATION

1. Insert ends of capillary tubes (11) through hole in housing partition (10), being careful to avoid kinking tubes.
2. Connect capillary tube flare nuts (8) to fittings (9).
3. Install switches (6 and 7) and secure with four screws (4) and four lockwashers (5) to bracket (3). Keep excess capillary tubing coiled neatly without kinks.
4. Secure bracket with screws (1) and lockwashers (2).
5. Connect electrical leads and remove tags.

INSTALLATION - Continued

6. Install mist eliminator bracket.
7. Replace filter-drier (See WP 0066-00).
8. Leak test refrigerant system (See WP 0052-00).
9. Evacuate refrigerant system (See WP 0053-00).
10. Charge system (See WP 0054-00).
11. Install remote control module and circuit breaker panel (See WP 0033-00 and WP 0034-00).
12. Install top covers (See WP 0019-00).

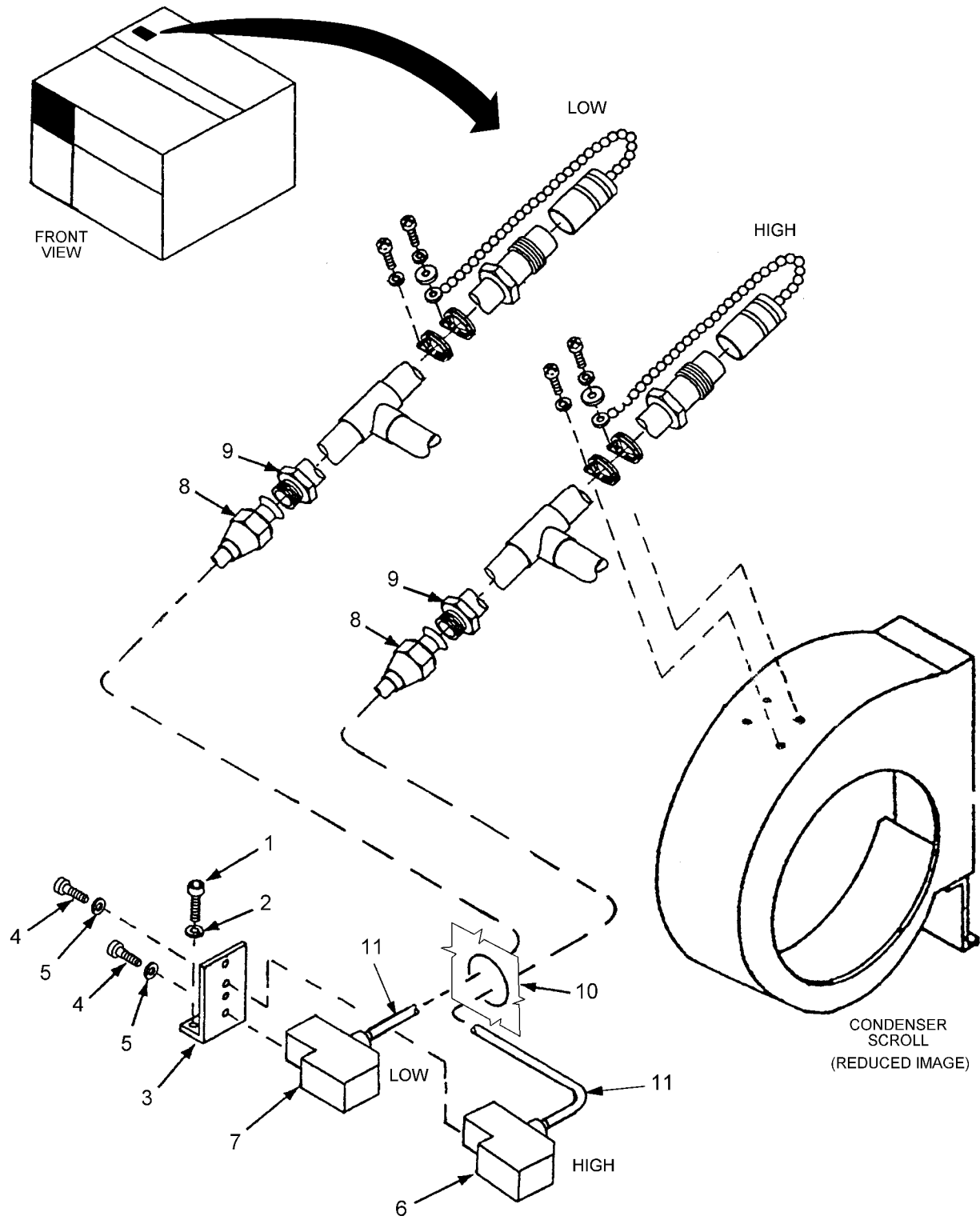

END OF TASK

SERVICE VALVES DIRECT SUPPORT MAINTENANCE REPLACEMENT

0073-00

THIS WORK PACKAGE COVERS:

Inspect, Removal, and Installation

INITIAL SETUP:

Maintenance Level

Direct Support

Tools and Special Tools

Tool Kit, General Mechanics (Item 1, Table 2, WP 0118-00)

Tool Kit, Service, Refrigeration Unit (Item 2, Table 2, WP 0118-00)

Recovery and Recycle Unit, Refrigerant, (Item 5, Table 2, WP 0118-00)

Mask, Air Filtering (Item 29, Table 1, WP 0121-00)

References

WP 0118-00 (MAC)

Equipment Condition

Mode selector switch in OFF position.

Main power source is disconnected.

Rear top panel removed (WP 0019-00).

System refrigerant discharged (WP 0049-00).

Test Equipment

Electronic refrigerant gas leak detector

Materials/Parts

Nitrogen (Item 4, Table 1, WP 0121-00)

Brazing alloy (Item 5 or 6, Table 1, WP 0121-00)

Brazing flux (Item 7, Table 1, WP 0121-00)

Special Environmental Condition

NOTE

In accordance with Environmental Protection Agency regulations, refrigerants cannot be discharged into the atmosphere. A refrigerant recovery and recycling unit must be used whenever discharging the refrigerant system.

Operation of the recovery/recycling unit must be by AUTHORIZED PERSONNEL ONLY.

WARNING

Avoid bodily contact with liquid refrigerant and avoid inhaling refrigerant gas. Be especially careful that refrigerant does not come in contact with eyes. In case of refrigerant leaks, ventilate area immediately.

WARNING

Check that power source is disconnected. Check that system is discharged of refrigerant.

INSPECT**Interior of Housing**

1. Visually inspect all valves for signs of damage.
2. Inspect valve fittings for leaks.
3. Inspect internal valve core (tire type valve). Replace if defective.

REMOVAL

1. Remove four screws (1), four lockwashers (2), two flat washers (3), and four clamps (4) to release service valves (6) and tubing (8) from scroll (9).
2. Debraze service valves (6) from tubing (8) (See WP 0051-00).

INSTALLATION

1. Purge system (See WP 0050-00).
2. Braze service valves (5) to refrigerant piping (8) (See WP 0051-00).
3. Secure service valves to condenser scroll with screws (1), lockwashers (2), flat washers (3) and clamps (4).
4. Replace filter-drier (See WP 0066-00).
5. Leak test refrigeration system (See WP 0052-00).
6. Evacuate refrigeration system (See WP 0053-00).
7. Charge refrigeration system (See WP 0054-00).
8. Secure valve caps (5).
9. Install rear top panel (See WP 0019-00).

INSTALLATION-Continued

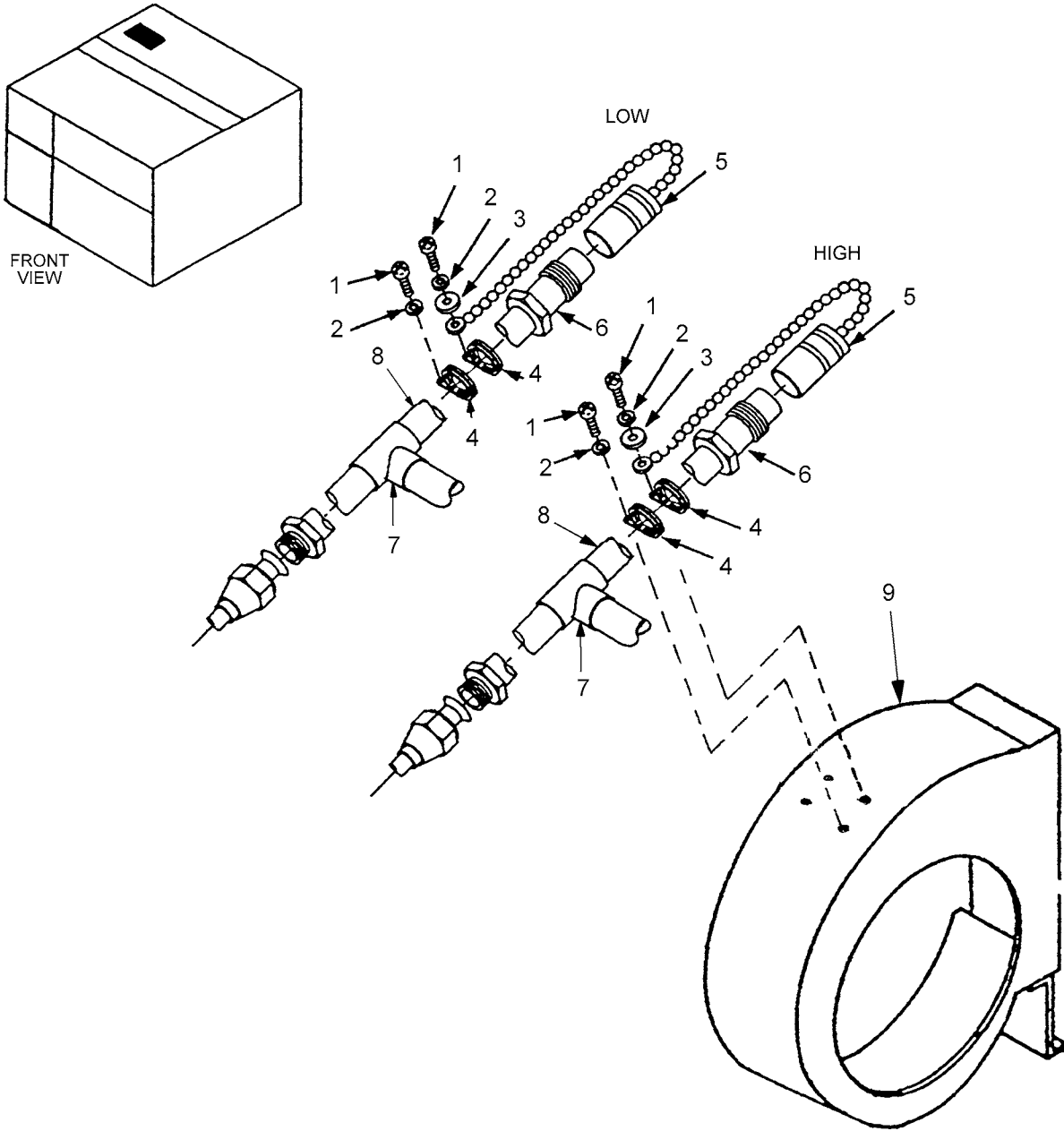

END OF TASK

EXPANSION VALVE DIRECT SUPPORT MAINTENANCE REPLACEMENT

0074-00

THIS WORK PACKAGE COVERS:

Removal and Installation

INITIAL SETUP:

Maintenance Level

Direct Support

Tools and Special Tools

Tool Kit, General Mechanics (Item 1, Table 2, WP 0118-00)

Tool Kit, Service, Refrigeration Unit (Item 2, Table 2, WP 0118-00)

Recovery and Recycle Unit, Refrigerant, (Item 5, Table 2, WP 0118-00)

Mask, Air Filtering (Item 29, Table 1, WP 0121-00)

References

WP 0118-00 (MAC)

Equipment Condition

Mode selector switch in OFF position.

Main power source is disconnected.

Top panels removed (WP 0019-00).

System refrigerant discharged (WP 0049-00).

Test Equipment:

Electronic refrigerant gas leak detector

Materials/Parts

Nitrogen (Item 4, Table 1, WP 0121-00)

Brazing alloy (Item 5 or 6, Table 1, WP 0121-00)

Brazing flux (Item 7, Table 1, WP 0121-00)

Warm, soapy water

Cloth, lint-free (Item 9, Table 1, WP 0121-00)

Special Environmental Condition

NOTE

In accordance with Environmental Protection Agency regulations, refrigerants cannot be discharged into the atmosphere. A refrigerant recovery and recycling unit must be used whenever discharging the refrigerant system.

Operation of the recovery/recycling unit must be by AUTHORIZED PERSONNEL ONLY.

WARNING

Individuals who have chronic or recurrent respiratory conditions, including allergies and asthma, should not be employed in this environment.

WARNING

Avoid bodily contact with liquid refrigerant and avoid inhaling refrigerant gas. Be especially careful that refrigerant does not come in contact with eyes. Use a air filtering mask. In case of refrigerant leaks, ventilate area immediately.

WARNING

Check that power source is disconnected. Check that system is discharged of refrigerant.

CAUTION

When performing brazing/debrazing operations, wrap valves with wet rags to act as a heat sink.

NOTE

Replace filter-drier whenever refrigerant system is opened.

REMOVAL**Expansion Valve**

1. Locate bulb (1) strapped with insulation (2) to suction line (3).
2. Remove insulation (2) covering bulb (1).
3. Withdraw bulb (1) from suction line (3) taking care to prevent damage to capillary tubes (4).
4. With dry nitrogen flowing through refrigerant system, debraze tubing to valve (8) at debrazing point (5, 6 and 7) (See WP 0051-00).
5. Remove expansion valve (8) from unit.

CAUTION

Damaged capillary will cause unit to malfunction. Use care not to damage or kink capillary.

INSTALLATION

Expansion Valve

1. With dry nitrogen flowing through refrigeration system, braze valve to tubing (See WP 0051-00).

CAUTION

Take care to avoid kinking capillary tube.

2. Coil excess capillary tubing.
3. Secure bulb (1) with insulation (2) to suction line (3).
4. Insulate bulb and area around bulb.
5. Replace filter-drier (WP 0066-00).
6. Leak test refrigeration system (WP 0052-00).
7. Evacuate refrigeration system (WP 0053-00).
8. Charge refrigeration system (WP 0054-00).
9. Install top panels (WP 0019-00).

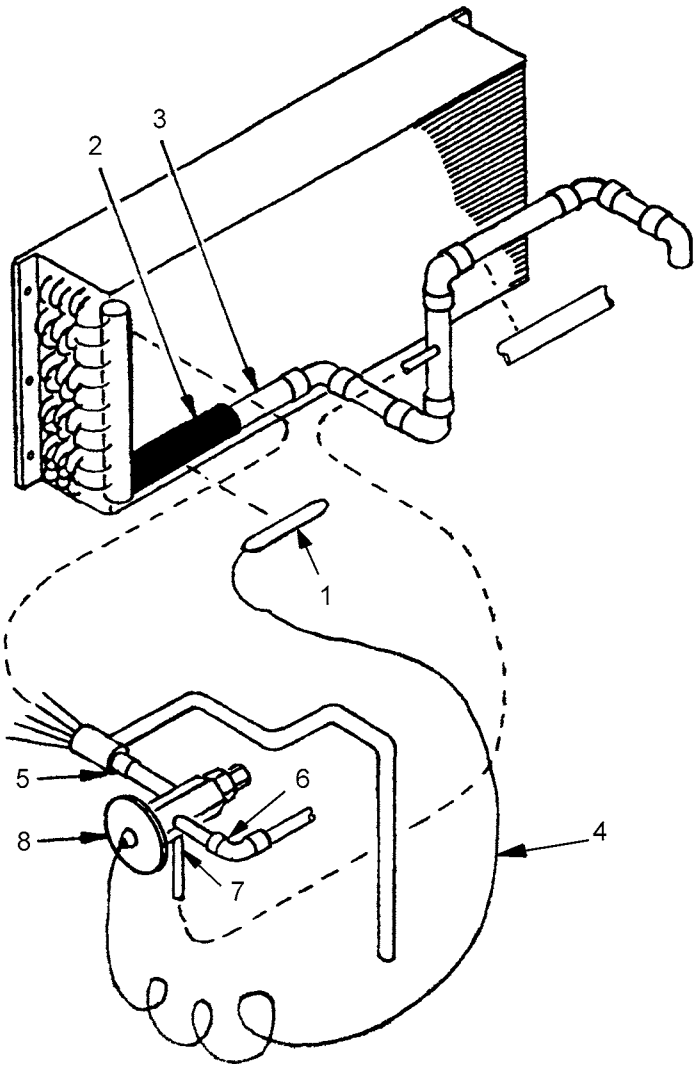
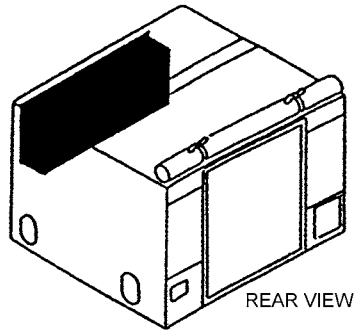

END OF TASK

LIQUID SIGHT INDICATOR DIRECT SUPPORT MAINTENANCE REPLACEMENT

0075-00

THIS WORK PACKAGE COVERS:

Removal, and Installation

INITIAL SETUP:

Maintenance Level

Direct Support

Tools and Special Tools

Tool Kit, General Mechanics (Item 1, Table 2, WP 0118-00)

Tool Kit, Service, Refrigeration Unit (Item 2, Table 2, WP 0118-00)

Recovery and Recycle Unit, Refrigerant, (Item 5, Table 2, WP 0118-00)

Mask, Air Filtering (Item 29, Table 1, WP 0121-00)

References

WP 0118-00 (MAC)

Equipment Condition

Mode selector switch in OFF position.

Main power source is disconnected.

Top rear panel removed (WP 0019-00).

System refrigerant discharged (WP 0049-00).

Test Equipment

Electronic refrigerant gas leak detector

Materials/Parts

Nitrogen (Item 4, Table 1, WP 0121-00)

Brazing alloy (Item 5 or 6, Table 1, WP 0121-00)

Brazing flux (Item 7, Table 1, WP 0121-00)

Special Environmental Condition

NOTE

In accordance with Environmental Protection Agency regulations, refrigerants cannot be discharged into the atmosphere. A refrigerant recovery and recycling unit must be used whenever discharging the refrigerant system.

Operation of the recovery/recycling unit must be by AUTHORIZED PERSONNEL ONLY.

**LIQUID SIGHT INDICATOR
DIRECT SUPPORT MAINTENANCE REPLACEMENT - Continued**

0075-00

WARNING

Check that power source is disconnected. Check that refrigerant system is discharged.

REMOVAL

1. Remove screw (1), washer (2) and mounting plate (3) to release the liquid sight indicator (4) from side of housing.
2. With a steady flow of dry nitrogen through refrigeration system, debraze liquid sight indicator from condenser coil and attached tubing (See WP 0050-00 and WP 0051-00).

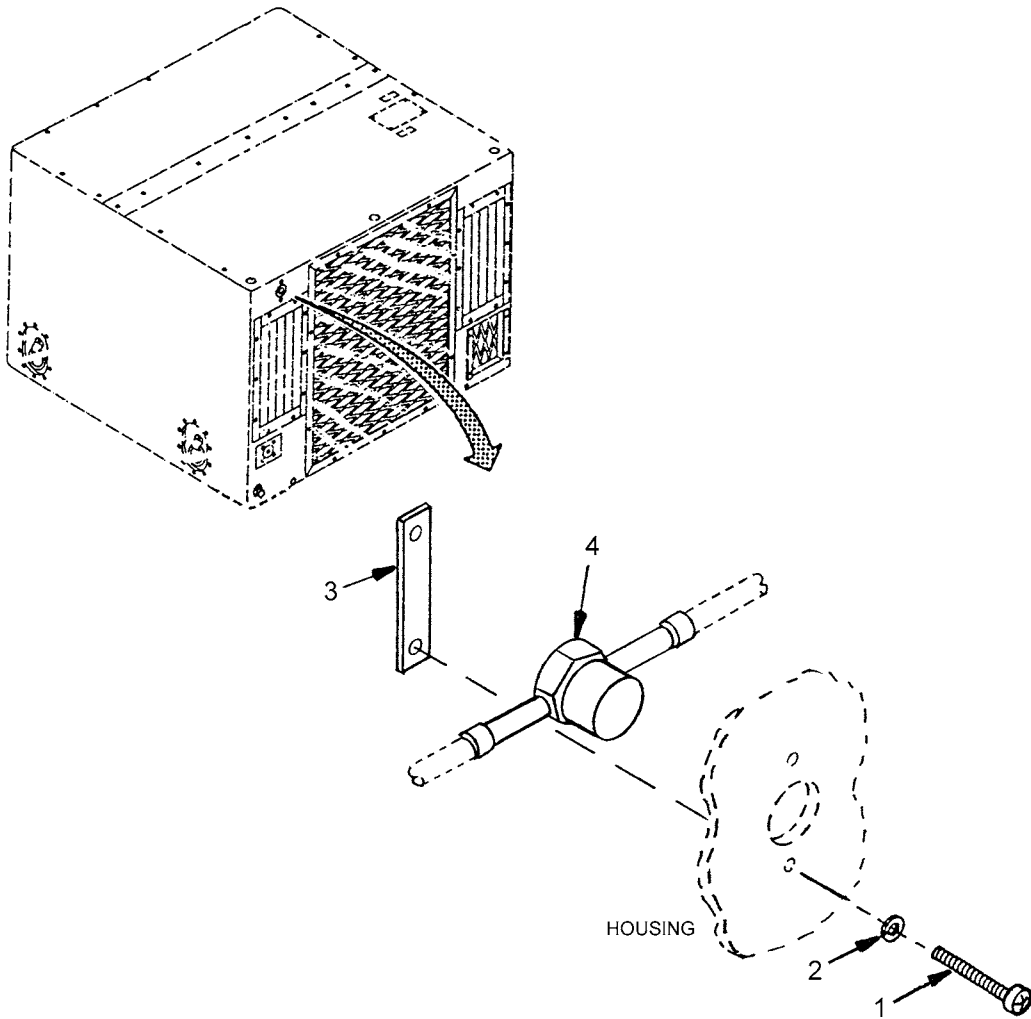

**LIQUID SIGHT INDICATOR
DIRECT SUPPORT MAINTENANCE REPLACEMENT - Continued**

0075-00

INSTALLATION

1. With a steady flow of dry nitrogen through refrigeration system, braze liquid sight indicator onto condenser coil and tubing (See WP 0050-00 and WP 0051-00).
2. Install condenser coil assembly (See WP 0078-00).
3. Install filter-drier (See WP 0066-00).
4. Leak test refrigeration system (See WP 0052-00).
5. Evacuate refrigerant system (See WP 0053-00).
6. Charge refrigerant system (See WP 0054-00).
7. Install rear top panel (See WP 0019-00).

END OF TASK

COMPRESSOR DIRECT SUPPORT MAINTENANCE REPLACEMENT

0076-00

THIS WORK PACKAGE COVERS:

Test, Removal, Decontamination, Repair, and Installation

INITIAL SETUP:

Maintenance Level

Direct Support

Tools and Special Tools

Tool Kit, General Mechanics (Item 1, Table 2, WP 0118-00)
Tool Kit, Service, Refrigeration Unit (Item 2, Table 2, WP 0118-00)
Recovery and Recycle Unit, Refrigerant (Item 5, Table 2, WP 0118-00)
Lifting Device
Mask, Air Filtering (Item 29, Table 1, WP 0121-00)

Personnel Required

Two people needed for compressor removal and installation.

References

WP 0118-00 (MAC)

Equipment Condition

Mode selector switch in OFF position.
Main power source is disconnected.
Panels removed (WP 0019-00).
System refrigerant discharged (WP 0049-00).
Condenser motors and condenser impeller fans removed (WP 0062-00).
Condenser fan scrolls removed (WP 0063-00).
Condenser fan supports removed (WP 0064-00).
Damper actuator cylinder removed (WP 0068-00).

Test Equipment:

Multimeter

Materials/Parts

Nitrogen (Item 4 Table 1, WP 0121-00)
Braze alloy (Item 5 or 6, Table 1, WP 0121-00)
Braze flux (Item 7, Table 1, WP 0121-00)

Special Environmental Condition

NOTE

In accordance with Environmental Protection Agency regulations, refrigerants cannot be discharged into the atmosphere. A refrigerant recovery and recycling unit must be used whenever discharging the refrigerant system.

Operation of the recovery/recycling unit must be by AUTHORIZED PERSONNEL ONLY.

WARNING

Compressor weighs as much as 92 lbs. (41.72 kg) and could cause injury to personnel and damage to equipment if not handled properly while removing from unit. Two personnel are required to lift the compressor.

CAUTION

When an overhead lifting device is used to remove the condenser fan supports (WP 0064-00), use an appropriate sling so that the weight of the unit is supported by the base of the shipping container.

WARNING

Do not allow the unit to swing while suspended from a lifting device. Failure to observe this warning may result in injury to personnel and damage to the equipment.

WARNING

Disconnect air conditioner power supply.

WARNING

Purge system with dry nitrogen prior to soldering or de-soldering; refrigerant heated by flame or hot surfaces creates phosgene gas, a highly toxic gas.

WARNING

Do not let refrigerant touch you or inhale refrigerant gas. Be especially careful to prevent refrigerant from coming in contact with your eyes. Use a air filtering mask. In case of refrigerant leaks, ventilate area at once.

WARNING

Follow general debrazing instructions given in WP 0051-00. Provide a flow of dry nitrogen through the refrigeration system while debrazing connections.

WARNING

Never operate compressor without the compressor terminal cover secured in place.

TEST

1. Remove cover from compressor (8) terminal box (1).
2. Tag and disconnect terminal lugs. See schematic diagram, WP 0122-00.
3. Using a multimeter, test for continuity between pins T1 and T2, T2 and T3, and T3 and T1 of the compressor electrical receptacle. Continuity should exist. If not, replace compressor.
4. Check for continuity between pins T1, T2 and T3 and the compressor housing. No continuity should exist. If continuity exists, replace compressor.

REMOVAL

1. With dry nitrogen flowing through refrigerant system, debraze tubing attached to compressor (See WP 0051-00).

NOTE

The compressor is mounted on the compressor mounting plate (11) by bolts that are welded to the plate. It is not necessary to remove the plate (10) and its attaching parts (9) and (10) unless it is damaged.

2. Remove four nuts (2), four flat washers (3) and four grommets (4) securing compressor (8) to plate (11).

WARNING

Compressor weighs as much as 92 lbs. (41.72 kg) and could cause injury to personnel and damage to equipment if not handled properly while removing from unit. Two personnel are required to lift the compressor.

3. Carefully lift up compressor from unit.
4. Remove four resilient mounts (5) from compressor. Inspect for wear or damage. Replace as necessary.
5. Remove four spacers (6) and (7). Inspect for damage. Replace as necessary.

DECONTAMINATION

1. After removal of a bad compressor from the refrigeration system, tip the compressor toward the discharge port to drain sample of oil into a clear glass container.

WARNING

Avoid inhaling fumes and burns from any acid formed by burnout of oil and refrigerant.

2. If the oil is clean and clear, and does not have a burnt acid smell, the compressor did not fail because of motor burn out. If a burn out is not indicated, refer to direct support troubleshooting WP 0047-00 for other malfunction causes.
3. If the oil is black, contains sludge, and has a burnt acid odor, the compressor failed because of motor burn out. Proceed to replace the compressor.

REPAIR**Wiring**

1. Remove the insulation to expose ½ inch (1.27 cm) of bare wire on each side of break or damaged insulation.
2. Insert the ends into a splice-connector; splice and crimp the connector to make firm electrical contact.
3. Alternatively, heat-shrink tubing may be slipped over one end of the wire before splicing, then heated after the splice is made and soldered so as to cover the spliced area.
4. Be sure that no bare wire is exposed after the splice is complete.
5. Replace broken terminal lugs with exact duplicates.
6. Check continuity terminal-to-terminal.

INSTALLATION

1. Install four rubber spacers (7) on to compressor mounting plate (11) welded bolts.
2. Install four spacers (6) on to plate (11) bolts.
3. Install four resilient mounts (5).
4. Install four grommets (4) on to compressor mounting hole.
5. Carefully position new compressor having a full and proper charge of synthetic oil on compressor mounting plate bolts (11).
6. Secure compressor with four nuts (2) and flat washer (3).
7. Replace filter-drier. See WP 0066-00.
8. Connect piping. Provide a flow of dry nitrogen through the system to protect inside surfaces of refrigerant piping from scaling while brazing (WP 0051-00).
9. Install condenser fan supports. See WP 0064-00.
10. Install condenser fan scrolls. See WP 0063-00.
11. Install condenser motors and impeller fans. See WP 0062-00.
12. Install damper actuator cylinder. See WP 0068-00.
13. Preliminary leak test unit. See WP 0052-00.
14. Evacuate the system. See WP 0053-00.
15. Charge unit with refrigerant R-22. See WP 0054-00.
16. Install top covers. See WP 0019-00.
17. Start the air conditioner and operate the unit for 3 hours.

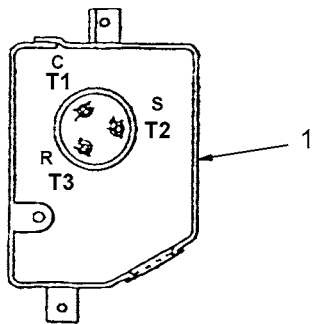
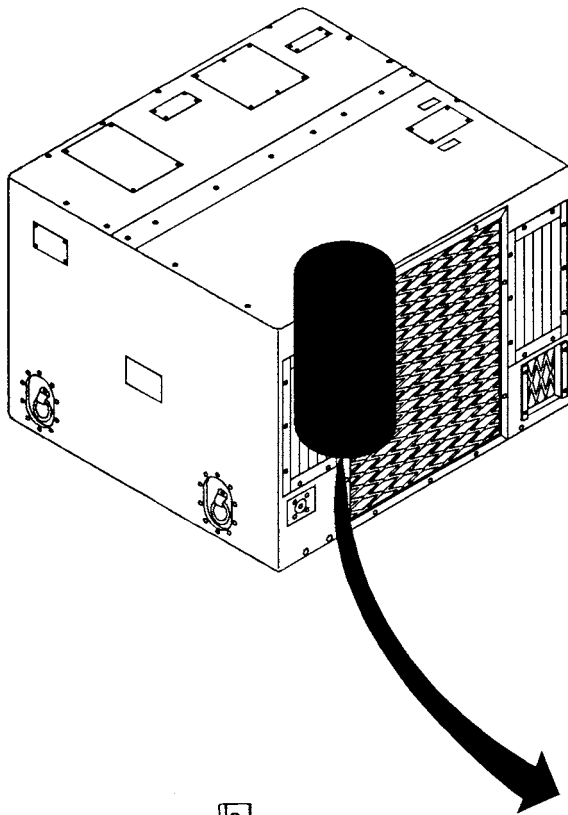

DETAIL "A"

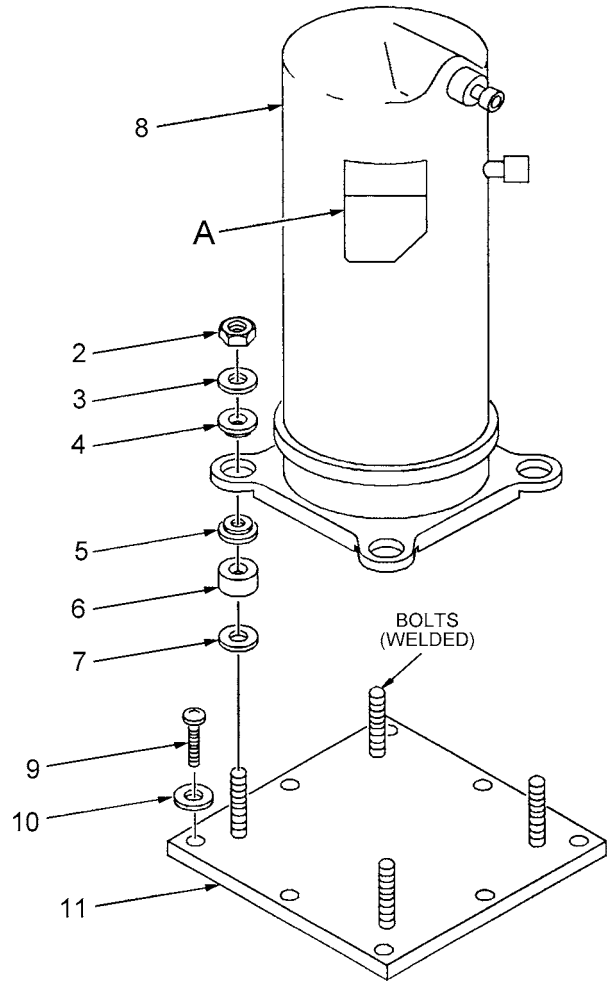

Compressor

END OF TASK

EVAPORATOR COIL DIRECT SUPPORT MAINTENANCE REPLACEMENT

0077-00

THIS WORK PACKAGE COVERS:

Removal, Inspection, Cleaning and Installation

INITIAL SETUP:

Maintenance Level

Direct Support

Tools and Special Tools

Tool Kit, General Mechanics (Item 1, Table 2, WP 0118-00)
Tool Kit, Service, Refrigeration Unit (Item 2, Table 2, WP 0118-00)
Recovery and Recycle Unit, Refrigerant, (Item 5, Table 2, WP 0118-00)
Mask, Air Filtering (Item 29, Table 1, WP 0121-00)

References

WP 0118-00 (MAC)

Equipment Condition

Mode selector switch in OFF position.
Main power source is disconnected.
Top panels removed (WP 0019-00).
Evaporator air discharge louver removed (WP 0020-00).
Mist eliminator removed (WP 0026-00).
Heating elements and switches removed (See WP 0027-00 and WP 0028-00).
System refrigerant discharged (WP 0049-00).

Test Equipment:

Electronic refrigerant gas leak detector

Materials/Parts

Dry Cleaning solvent (P-D 680) (Item 16, Table 1, WP 0121-00)
Nitrogen (Item 4, Table 1, WP 0121-00)
Brazing alloy (Item 5 or 6, Table 1, WP 0121-00)
Brazing flux (Item 7, Table 1, WP 0121-00)
Warm, soapy water
Brush, wire
Cloth, lint-free (Item 9, Table 1, WP 0121-00)

Special Environmental Condition

NOTE

In accordance with Environmental Protection Agency regulations, refrigerants cannot be discharged into the atmosphere. A refrigerant recovery and recycling unit must be used whenever discharging the refrigerant system.

Operation of the recovery/recycling unit must be by AUTHORIZED PERSONNEL ONLY.

WARNING

Disconnect air conditioner power supply.

WARNING

Purge system with dry nitrogen prior to soldering or de-soldering; refrigerant heated by flame or hot surfaces creates phosgene gas, a highly toxic gas.

WARNING

Do not let refrigerant touch you or inhale refrigerant gas. Be especially careful to prevent refrigerant from coming in contact with your eyes. Wear air filter mask for protection. In case of refrigerant leaks, ventilate area at once.

WARNING

Follow general debrazing instructions given in WP 0051-00. Provide a flow of dry nitrogen through the refrigeration system while debrazing connections.

REMOVAL

1. Remove six screws (1), securing evaporator coil (3) to housing.
2. Debraze tubing from evaporator coil and expansion valve subassembly. See debrazing joints (4 and 5).
3. Carefully lift the evaporator coil and expansion valve subassembly from the air conditioner.
4. Debraze the distributor (6) from the expansion valve (7) (See WP 0051-00).
5. Remove insulation to release sensor bulb (9) from suction return line (8).
6. Debraze suction return line (8) from evaporator coil (3) (See WP 0051-00).
7. Remove filter-drier (WP 0066-00).

INSPECTION

Inspect the evaporator coil for bent or torn fins and for damaged connections.

CLEANING

WARNING

Clean parts in a well-ventilated area. Avoid inhalation of solvent fumes and prolonged exposure of skin to cleaning solvent. Wash exposed skin thoroughly. Dry cleaning solvent, P-D-680 Type III, which is used to clean parts, is potentially dangerous to personnel and property. Avoid repeated and prolonged skin contact. Do not use near open flame or excessive heat. Flash point of solvent is 100 °F to 138 °F (38 °C to 59 °C).

Clean coil using cleaning solvent (Item 16, Table 1, WP 0121-00) and soft brush.

INSTALLATION

1. Connect tubing to coil (3), distributor (6) and expansion valve (7) to form the evaporator coil and expansion valve subassembly.
2. Install sensor bulb (9) and insulation to suction line (8).
3. Place the subassembly into the unit and braze at brazing joints (4) and (5). Before brazing joints, provide a flow of dry nitrogen through refrigeration system to protect internal surfaces of the tubing and fittings. (See WP 0051-00.)
4. Secure coil to housing with six screws (1).
5. Install new filter-dryer. (See WP 0066-00.)
6. Leak test system. (See WP 0052-00.)
7. Evacuate system. (See WP 0053-00.)
8. Charge system. (See WP 0054-00.)
9. Install evaporator air discharge louver. (See WP 0020-00.)
10. Install mist eliminator. (See WP 0026-00.)
11. Install top covers. (See WP 0019-00.)

INSTALLATION-Continued

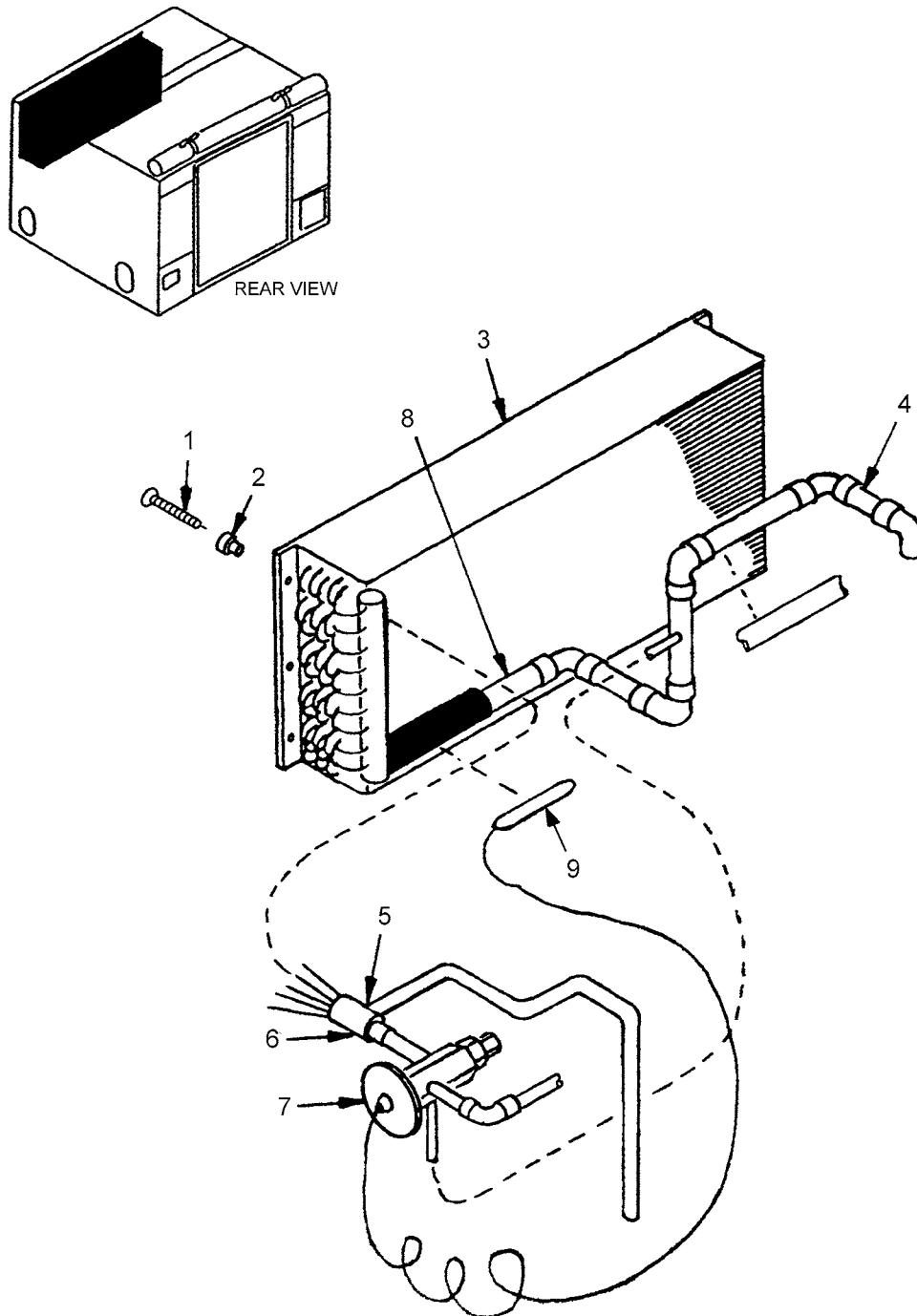

END OF TASK

CONDENSER COIL DIRECT SUPPORT MAINTENANCE REPLACEMENT

0078-00

THIS WORK PACKAGE COVERS:

Removal, and Installation

INITIAL SETUP:

Maintenance Level

Direct Support

Tools and Special Tools

Tool Kit, General Mechanics (Item 1, Table 2, WP 0118-00)
Tool Kit, Service, Refrigeration Unit (Item 2, Table 2, WP 0118-00)
Recovery and Recycle Unit, Refrigerant, (Item 5, Table 2, WP 0118-00)
Mask, Air Filtering (Item 29, Table 1, WP 0121-00)

References

WP 0118-00 (MAC)
WP 0075-00 (Liquid sight indicator)

Equipment Condition

Mode selector switch in OFF position.
Main power source is disconnected.
Panels removed (WP 0019-00).
System refrigerant discharged (WP 0049-00).
Condenser motors and condenser impeller fans removed (WP 0062-00).
Condenser fan scrolls removed (WP 0063-00).
Condenser fan supports removed (WP 0064-00).
Damper actuator cylinder removed (WP 0068-00).

Test Equipment

Electronic refrigerant gas leak detector

Materials/Parts

Dry cleaning solvent (P-D 680) (Item 16, Table 1, WP 0121-00)
Nitrogen (Item 4, Table 1, WP 0121-00)
Brazing alloy (Item 5 or 6, Table 1, WP 0121-00)
Brazing flux (Item 7, Table 1, WP 0121-00)
Warm, soapy water
Brush, wire
Cloth, lint-free (Item 9, Table 1, WP 0121-00)
Oil (Item 14, Table 1, WP 0121-00)

Special Environmental Condition

NOTE

In accordance with Environmental Protection Agency regulations, refrigerants cannot be discharged into the atmosphere. A refrigerant recovery and recycling unit must be used whenever discharging the refrigerant system.

Operation of the recovery/recycling unit must be by AUTHORIZED PERSONNEL ONLY.

WARNING

Ensure power source is disconnected. Ensure refrigerant system is discharged.

REMOVAL

1. Remove four screws (1), four lockwashers (2), four nuts (3), and gasket (4) attaching alternate power input receptacle J1 (5) to housing.

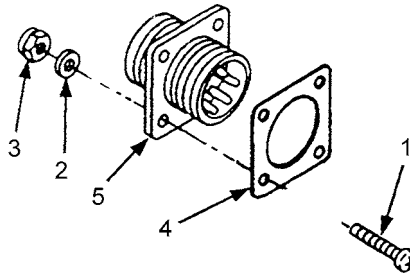

2. Move alternate power receptacle J1 (5) and wiring to aid in condenser coil removal.
3. Remove two screws (6), two lockwashers (7), and mounting plate (8) attaching liquid sight indicator (9) to housing (See WP 0075-00).

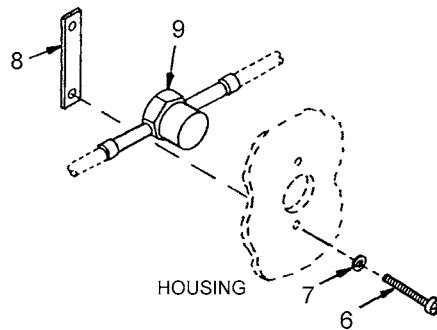

4. Remove damper actuator cylinder (See WP 0068-00).
5. Purge system (See WP 0050-00).
6. Reposition electrical wiring away from piping area to be debrazed.
7. Debrazed condenser tube connections (See WP 0051-00).
8. Debrazed filter-drier (See WP 0066-00).

CAUTION

Use extreme care in removing condenser coil from housing to avoid damaging fins and coil piping.

REMOVAL - Continued

9. Remove two screws (10) and condenser coil (11) from unit.
10. Debraze liquid sight indicator (9) from condenser coil (See WP 0051-00).

INSTALLATION

1. Braze the liquid sight indicator (9) onto the condenser coil (11) (See WP 0051-00).

CAUTION

Use extreme care in installing condenser coil assembly into housing to avoid damaging fins, coil, piping and refrigerant system tubing.

2. Place condenser coil and liquid sight indicator assembly into air conditioner. Secure coil with two screws.
3. Install damper actuator cylinder (See WP 0068-00).
4. Install condenser fan supports (See WP 0064-00).
5. Install condenser fan scrolls (See WP 0063-00).
6. Install condenser motors and condenser impeller fans (WP 0062-00).
7. Purge system (See WP 0050-00).
8. Braze condenser tube connections (See WP 0051-00).
9. Replace filter-drier (See WP 0066-00).
10. Install condenser guard with screws and lockwashers (See WP 0024-00).
11. Secure liquid sight indicator with two screws (6), two lockwashers (7) and mounting plate (8) (See WP 0075-00).
12. Leak test refrigeration system (See WP 0052-00).
13. Reposition electrical wiring to original position and tie as required.
14. Install alternate power receptacle J1 (5) and wiring and secure to housing using four screws (1), four lockwashers (2), and four nuts (3).
15. Install rear top panel (See WP 0019-00).
16. Evacuate refrigeration system (See WP 0053-00).
17. Charge refrigeration system (See WP 0054-00).

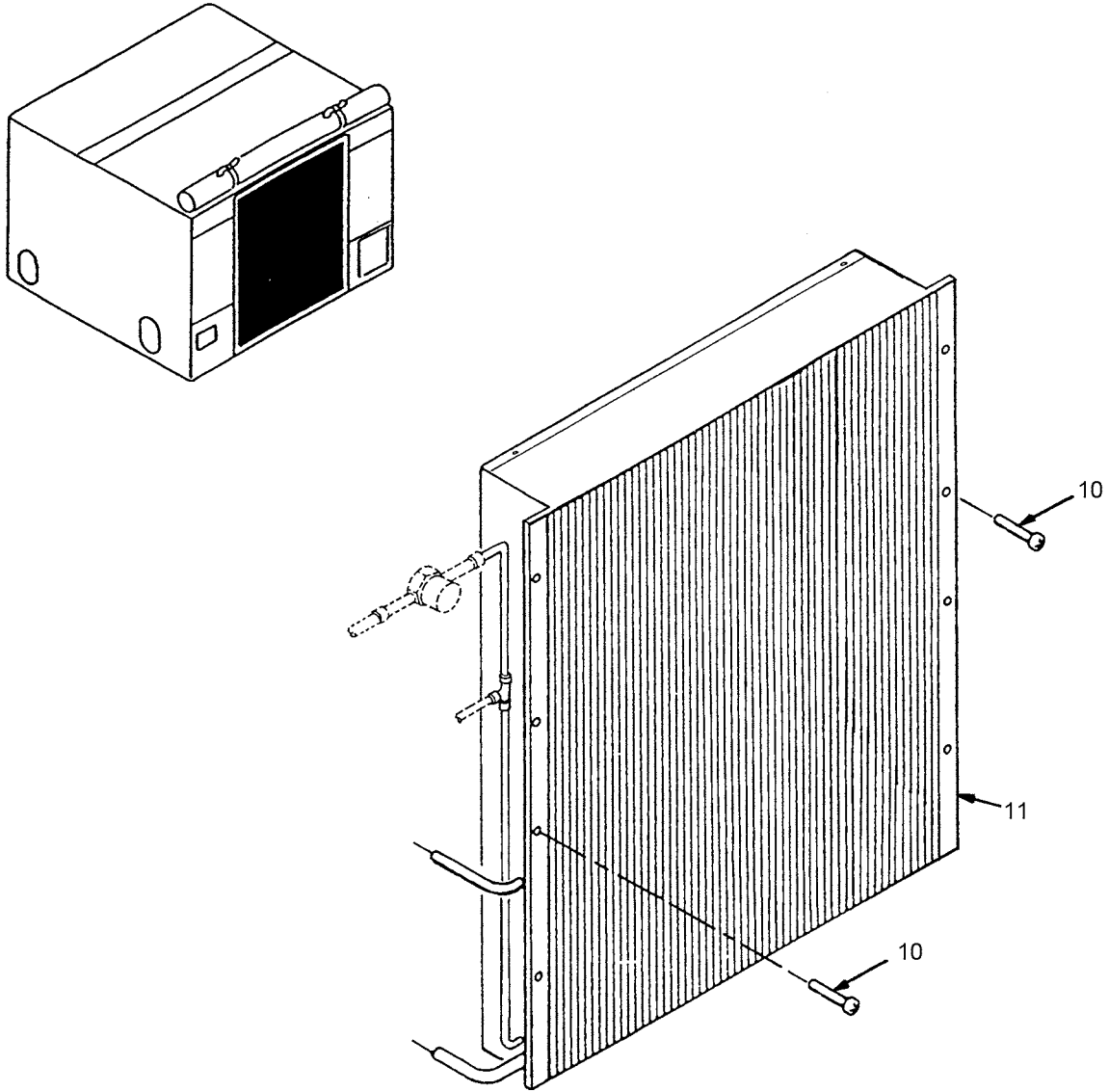

END OF TASK

THIS WORK PACKAGE COVERS:

Test, Removal and Installation

INITIAL SETUP:

Maintenance Level

Direct Support

Tools and Special Tools

Tool Kit, General Mechanics (Item 1, Table 2, WP 0118-00)

Tool Kit, Service, Refrigeration Unit (Item 2, Table 2, WP 0118-00)

Recovery and Recycle Unit, Refrigerant (Item 5, Table 2, WP 0118-00)

Mask, Air Filtering (Item 29, Table 1, WP 0121-00)

References

WP 0118-00 (MAC)

Equipment Condition

Mode selector switch in OFF position.

Main power source is disconnected.

Top covers removed (WP 0019-00).

Test Equipment

Electronic refrigerant gas leak detector

Materials/Parts

Nitrogen (Item 4, Table 1, WP 0121-00)

Brazing alloy (Item 5 or 6, Table 1, WP 0121-00)

Brazing flux (Item 7, Table 1, WP 0121-00)

Special Environmental Condition

NOTE

In accordance with Environmental Protection Agency regulations, refrigerants cannot be discharged into the atmosphere. A refrigerant recovery and recycling unit must be used whenever discharging the refrigerant system.

Operation of the recovery/recycling unit must be by AUTHORIZED PERSONNEL ONLY.

WARNING

Disconnect air conditioner power supply.

WARNING

Avoid bodily contact with liquid refrigerant and avoid inhaling refrigerant gas. Be especially careful that refrigerant does not come in contact with eyes. In case of refrigerant leaks, ventilate area immediately.

**TUBING AND FITTINGS DIRECT SUPPORT
MAINTENANCE REPLACEMENT - Continued**

0079-00

TEST

1. Check all piping and connections with a General Electric Type H-2 halogen test detector (or approved equal).
2. Calibrate the detector with a General Electric LS-20 leak standard (or approved equal) for a pure refrigerant leak rate of 0.1 ounce (2.8349 gms) per year.
3. Replace any piping or connection that is leaking beyond the rate of 0.1 ounce (2.8349 gms) per year.

REMOVAL

1. Debraze and remove tubing only when necessary to remove a defective part.
2. When brazing, constantly purge the refrigerant system with dry nitrogen to prevent scale formation within the refrigerant system. (See WP 0051-00).

INSTALLATION

1. Braze all copper-to-copper joints with silver solder (Item 21, Table 1, WP 0121-00).
2. Braze all copper-to-brass or copper-to-steel with silver solder.
3. Braze melting point is 1160°F(625°C).
4. Make all braze joints with an atmosphere of inert gas to prevent internal oxidation (See WP 0051-00).
5. Replace filter-drier prior to leak testing. See WP 0066-00.
6. Service refrigeration system after repairs (See WP 0049-00 through WP 0055-00).
7. Secure top cover and lower panel (See WP 0019-00).

END OF TASK

**TUBING AND FITTINGS DIRECT SUPPORT
MAINTENANCE REPLACEMENT - Continued**

0079-00

TEST

4. Check all piping and connections with a General Electric Type H-2 halogen test detector (or approved equal).
5. Calibrate the detector with a General Electric LS-20 leak standard (or approved equal) for a pure refrigerant leak rate of 0.1 ounce (2.8349 gms) per year.
6. Replace any piping or connection that is leaking beyond the rate of 0.1 ounce (2.8349 gms) per year.

REMOVAL

3. Debraze and remove tubing only when necessary to remove a defective part.
4. When brazing, constantly purge the refrigerant system with dry nitrogen to prevent scale formation within the refrigerant system. (See WP 0051-00).

INSTALLATION

8. Braze all copper-to-copper joints with silver solder (Item 21, Table 1, WP 0121-00).
9. Braze all copper-to-brass or copper-to-steel with silver solder.
10. Braze melting point is 1160°F(625°C).
11. Make all braze joints with an atmosphere of inert gas to prevent internal oxidation (See WP 0051-00).
12. Replace filter-drier prior to leak testing. See WP 0066-00.
13. Service refrigeration system after repairs (See WP 0049-00 through WP 0055-00).
14. Secure top cover and lower panel (See WP 0019-00).

END OF TASK

CHAPTER 9
GENERAL SUPPORT
MAINTENANCE INSTRUCTIONS

GENERAL SUPPORT MAINTENANCE

0080-00

THIS WORK PACKAGE COVERS:

Repair Parts, Special Tools, TMDE, and Support Equipment

General Information

Repair parts are listed and illustrated in Chapter 10 of this manual. No special tools are required for general support maintenance of the air conditioner. Test, Maintenance, and Diagnostic Equipment (TMDE) and support equipment include standard electrical test equipment, standard pressure and vacuum gauges, and vacuum servicing manifolds found in any general support maintenance refrigeration facility.

HOUSING GENERAL SUPPORT MAINTENANCE

0081-00

THIS WORK PACKAGE COVERS:

Inspection, Removal, Repair

INITIAL SETUP:

Maintenance Level

General Support

Tools and Special Tools

Tool Kit, General Mechanics (Item 1, Table 2, WP 0118-00)

Mask, Air Filtering (Item 29, Table 1, WP 0121-00)

References

WP 0118-00 (MAC)

Equipment Condition

Mode selector switch in OFF position.

Main power source is disconnected.

Materials/Parts

Adhesive (Item 18, Table 1, WP 0121-00)

Cellular rubber strips (Item 19, Table 1, WP 0121-00)

Elastomeric thermal insulation (Item 20, Table 1, WP 0121-00)

Cloth, lint-free (Item 9, Table 1, WP 0121-00)

Acetone (Item 22, Table 1, WP 0121-00)

Methyl-ethyl ketone (MEK) (Item 23, Table 1, WP 0121-00)

Paint, forest green (MIL-C-46168)

Paint brush

Sandpaper, 240 grit

Primer (TT-P-1757)

Special Environmental Condition

NOTE

In accordance with Environmental Protection Agency regulations, refrigerants cannot be discharged into the atmosphere. A refrigerant recovery and recycling unit must be used whenever discharging the refrigerant system.

Operation of the recovery/recycling unit must be by AUTHORIZED PERSONNEL ONLY.

WARNING

Disconnect air conditioner power supply.

WARNING

Acetone and methyl-ethyl ketone are flammable and their vapors are explosive. Prolonged or repeated inhalation of fumes or contact with the skin can be toxic. Use in a well-ventilated area, wear gloves and an air filtering mask, and keep away from sparks or flame.

INSPECTION

1. Inspect for damage. Look for loose, frayed, cracked and missing insulation.
2. Visually check for excessive drying of insulation or shrinkage.

REMOVAL

1. Scrape and pull off as much of the damaged insulation as possible.
2. Soften the remaining insulation and adhesive with acetone or MEK (methyl-ethyl ketone).
3. Repeat the softening and scraping process as required.
4. Clean up metal surfaces with cloth moistened in acetone or MEK.

INSULATION REPAIR

1. Repair loose or torn insulation with adhesive.
2. Replace frayed, cracked or missing insulation.
3. Cut a sheet of the proper insulating material to correct shape.
4. Coat the attaching side with adhesive, using a paint brush to ensure complete coverage.
5. Coat the metal with adhesive to which the insulation is to be attached.
6. Let both surfaces air-dry until the adhesive becomes tacky but will not stick to the fingers.
7. Starting at one corner or at a narrow edge, carefully bring the insulation into full contact with the metal.
8. Press into firm contact all over.
9. Allow sufficient time to dry thoroughly before installation.

HOUSING REPAIR

1. Visually inspect for nicks, gouges, dents, bare spots in paint and other defects which can be repaired.
2. Repair/replace handles and associated hardware.
3. Sand and paint any repaired area in housing, referencing TM 43-0139, Painting Instructions for Field Use.
4. Remove minor dents, and paint.
5. Remove any rust or other minor corrosive damage, and paint.

END OF TASK

SECTION 1
INTRODUCTION

1. SCOPE

This RPSTL lists and authorizes spares and repair parts; special tools; special test, measurement, and diagnostic equipment (TMDE), and other special support equipment required for the performance of Aviation Unit maintenance support of the 36,000 BTU Air Conditioner, Horizontal, Compact Unit, 50/60 Hertz. It authorizes the requisitioning, issue, and disposition of spares, repair parts and special tools as indicated by the source, maintenance, and recoverability (SMR) codes.

2. GENERAL

This Repair Parts and Special Tools List is divided into the following sections:

a. Section II. Repair Parts List. A list of spares and repair parts authorized by this RPSTL for use in the performance of maintenance. This list also includes parts which must be removed for replacement of the authorized parts. Parts lists are composed of functional groups in ascending alphanumeric sequence, with the parts in each group listed in ascending figure and item number sequence. Bulk materials are listed by item name FIG. BULK at the end of this section. Repair part kits are listed separately in their own functional group within Section II. Repair parts for reparable special tools are also listed in Section II. Items listed are shown on the associated illustration.

b. Section III. Special Tools List. A list of special tools, special TMDE, and other special support equipment authorized by this RPSTL as indicated by Basis of Issue (BOI) information in the DESCRIPTION AND USABLE ON CODE (UOC) column).

c. Section IV. Cross-Reference Indexes. There are two cross-reference indexes in this RPSTL: the National Stock Number Index and the Part Number Index. The National Stock Number Index refers you to the figure and item number. The Part Number refers you to the figure and item number.

3. EXPLANATION OF COLUMNS (Section II and III)

a. Item No. (Column (1)). Indicates the number used to identify items called out in the illustration.

b. SMR Code (Column (2)). The source, maintenance, and recoverability (SMR) code is a five-position code containing supply/requisitioning information, maintenance level authorization criteria and disposition instruction, as shown in the following breakout:

Source Code	Maintenance Code	Recoverability Code
<u>XX</u>	<u>XX</u>	<u>XX</u>
1 st two positions	3 ^d position	5 th position
How you get an item.	Who can install or use the item	Who deter- mines disposi- tion action on an unservice- able item.
	4 th position	
	Who can do complete repair (see note) on the item.	

NOTE

Complete repair: Maintenance capacity, capability, and

authority to perform all corrective maintenance tasks of the "repair" function in a use/user environment in order to restore serviceability to a failed item.

(1) **Source code.** The source code tells you how to get an item needed for maintenance, repair, or overhaul of an end item/equipment. Explanations of source codes follow:

<i>Code</i>	<i>Application/explanation</i>	
PA	Stocked items: use the applicable NSN to request/requisition items with these source codes. They are authorized to the level indicated by the code entered in the third position of the SMR code.	
PB		
PC		
PD		
PE		
PF		
PG		
NOTE Items coded PC are subject to deterioration		
part	KD	Items with these codes are not to be requisitioned individually. They are of a kit which is authorized to the maintenance level indicated in the third position of the SMR code. The complete kit must be requisitioned and applied.
	KF	
	KB	
MO - Made at unit/AVUM level	Items with these codes are not to be requested/requisitioned individually. They must be made from bulk material which is identified by the part number in the description and usable on code (UOC) column and listed in the Bulk Material group of the repair parts list.	
MF - Made at DS/AVIM level	If the item is authorized to you by the third position of the SMR code, but the source is made at a higher level, order the item from the higher level of maintenance.	
MH - Made at GS level		
ML - Made at Specialized Repair Activity		
AO - Assembled by unit/AVUM	Items with these codes are not to be requested/requested individually. The parts that make up the assembled item must be requisitioned or fabricated and assembled at the level of maintenance indicated by the source	
AF - Assembled by DS/AVIM	code. If the SMR code authorizes you to replace the item but the source code indicates the item is assembled at a higher level, order the item from the higher level of maintenance.	
AH - Assembled by GS		
AL - Assembled by SR		
AD - Assembled by Depot		

XA - Do not requisition an "XA" coded item. Order its next higher assembly. (Refer to NOTE below.)

XB - If an "XB" item is not available from salvage, order it using the CAGEC and part number given.

XC - Installation drawing, diagram, instruction sheet, field service drawing that is identified by manufacturer's part number.

NOTE

Cannibalization or controlled exchange, when authorized, may be used as a source of supply for items with the above source codes, except for those source coded "XA" or those aircraft support items restricted by requirements of AR 750-1.

(2) Maintenance code. Maintenance codes tell you the level of maintenance authorized to USE and REPAIR support items. The maintenance codes are entered in the third and fourth positions of the SMR code as follows:

(a) The maintenance code entered in the third position tells you the lowest maintenance level authorized to remove, replace, and use an item. The maintenance code entered in the third position will indicate authorization to one of the following levels of maintenance.

Maintenance Code

Application/Explanation

C - Crew or operator maintenance done within unit/AVUM maintenance.

O - Unit level/AVUM maintenance can remove, replace, and use the item.

F - Direct support/AVIM maintenance can remove, replace, and use the item.

H - General support maintenance can remove, replace, and use the item.

L - Specialized repair activity can remove, replace, and use the item.

D - Depot can remove, replace, and use the item.

(b) The code entered in the fourth position tells whether or not the item is to be repaired and identifies the lowest maintenance level with the capability to do complete repair (perform all authorized repair functions).

NOTE

Some limited repair may be done on the item at a lower level of maintenance, if authorized by the Maintenance Allocation Chart (MAX) and SMR codes.

Maintenance Code

Application/Explanation

O - Unit/AVUM is the lowest level that can do complete repair of the item

F - Direct support/AVIM is the lowest level that can do complete repair of the item.

H - General support is the lowest level that can do complete repair of the item.

c. NSN (Column (3)). The national stock number for the item is listed in this column.

d. CAGEC (Column (4)). The Commercial and Government Entity Code (CAGEC) is a 5-digit numeric code which is used to identify the manufacturer, distributor, or Government agency, etc., that supplies the item.

e. PART NUMBER (Column (5)). Indicates the primary number used by the manufacturer (individual, company, firm, corporation, or Government activity) which controls the design and characteristics of the item by means of its engineering drawings, specifications, standards, and inspection requirements to identify a range of items.

NOTE

When you use an NSN to requisition an item, the item you receive may have a different part number from the number listed.

L - Specialized repair activity (designate the specialized repair activity) is the lowest level that can do complete repair of the item.

D - Depot is the lowest level that can do complete repair of the item.

Z - Nonrepairable. No repair is authorized.

B - No repair is authorized. (No parts or special tools are assigned for the maintenance of a "B" coded item.) However, the item may be reconditioned by adjusting, lubricating, etc., at the user level.

(3) Recoverability code. Recoverability codes are assigned to items to indicate the disposition action on unserviceable items. The recoverability code is entered in the fifth position of the SMR code as follows:

<i>Code</i>	<i>Recoverability Application/Explanation</i>
-------------	---

Z - Nonrepairable item. When unserviceable, condemn and dispose of the item at the level of maintenance shown in the third position of SMR code.

O - Repairable item. When uneconomically repairable, condemn and dispose of the item at unit level.

F - Repairable item. When uneconomically repairable, condemn and dispose of the item at direct support level.

H - Repairable item. When uneconomically repairable, condemn and dispose of the item at general support level.

D - Repairable item. When beyond lower level repair capability, return to depot. Condemnation and disposal of item not authorized below depot level.

L - Repairable item. Condemnation and disposal not authorized below specialized repair activity (SRA).

A - Item requires special handling or condemnation procedures because of specific reasons (e.g., precious metal content, high dollar value, critical material, hazardous material), or return to Depot/Contractor for repair. Refer to appropriate manuals/directives for specific instructions.

f. DESCRIPTION AND USABLE ON CODE (UOC) (Column (6)). This column includes the following.

(1) The Federal item name and, when required, a minimum description to identify the item.

(2) Part numbers for bulk materials are referenced in this column in the line entry for the item to be manufactured/fabricated.

(3) The statement "END OF FIGURE" appears just below the last item description in Column (5) for a given figure in both section II and section III.

g. QTY (Column (6)). Indicates the quantity of the item used in the breakout shown on the illustration figure, which is prepared for a functional group, subfunctional group, or an assembly. A "V" appearing in this column in lieu of a quantity indicates that the quantity is variable and the quantity may vary from application to application.

4. EXPLANATION OF INDEX FORMAT AND COLUMNS (SECTION IV)

a. National Stock Number (NSN) Index.

(1) *STOCK NUMBER column.* This column lists the NSN by National item identification number (NIIN) sequence. The NIIN consists of the last nine digits of the NSN.

NSN
(e.g., 5385-01-574-1476)

When using this column to locate an item, ignore the first four digits of the NSN. Use the complete NSN (13 digits) when requisitioning items by stock number.

(2) *FIG. column.* This column lists the number of the figure where the item is identified/located. The illustrations are in numerical sequence in sections II and III.

(3) *ITEM column.* The item number identifies the item associated with the figure listed in the adjacent Fig. column. This item is also identified by the NSN listed on the same line.

b. Part Number Index. Part numbers in this index are listed by part number in ascending alphanumeric sequence (vertical arrangement of letters and number combination which places the first letter or digit of each group in order A through Z, followed by the numbers 0 through 9 and each following letter or digit in like order).

(1) *Part number column.* Indicates the part number assigned to the item.

(2) *Fig. column.* This column lists the number of the figure where the item is identified/located in sections II and III.

(3) *Item column.* The item number is the number assigned to the item as it appears in the figure referenced in the adjacent figure number column.

5. REFERENCE DESIGNATOR INDEX *(Not applicable)*

6. SPECIAL INFORMATION

a. Usable on Code. The usable on code appears in the lower left corner of the description column heading. Usable on codes are shown as "UOC: " in the description column (justified left) on the first line applicable item description nomenclature. Uncoded items are applicable to all models. Identification of the usable on codes used in this RPSTL are:

Code	Used on
24P	36,000 BTU Air Conditioner, NSN 4120-01-467-2638

b. Associated Publications. The publications listed below pertain to the (enter equipment)

c. Fabrication Instructions. Bulk materials required to manufacture items are listed in the bulk material functional group of this RPSTL. Part numbers for bulk materials are also referenced in the description column of the line item entry for the item to be manufactured/fabricated. Detailed fabrication instructions for items source coded to be manufactured or fabricated are found in TM 11-xxxx-xxx-xxx.

d. Assembly Instructions. Detailed assembly instructions for items source coded to be assembled from component spare/repair parts are found in xxxxxxxxxxxxxxxxxx. Items that make up the assembly are listed immediately following the assembly item entry or reference is made to an applicable item.

e. Kits. Line item entries for repair part kits appear in a group in Section II (refer to Table of Contents).

f. Index Numbers. Items which have the word BULK in the figure column will have an index number shown in the item number column. This index number is a cross-reference between the National Stock Number/Part Number index and the bulk material list in section II.

g. Illustrations - Listing. Illustrations in this RPSTL containing parts authorized at (enter level of maintenance) are identical to those published in TM 11-xxxx-xxx-xxx. Only those parts coded (enter code) in the third position of the SMR code are listed in the tabular listing in section II; therefore, there may be a break in the item number sequence. Only illustrations containing (enter level of maintenance) authorized items appear in this RPSTL.

h. National Stock Numbers. National Stock Numbers (NSNs) that are missing from "P" source coded items have been applied for and will be added to this TM by future change/revision when they are entered in the Army Master Data File (AMDF). Until the NSNs are established and published, submit exception requisitions to: Commander, U. S. Army Communications-Electronics Command and Fort Monmouth, ATTN: AMSEL-LC-MM, Fort Monmouth, NJ 07703-5007 for the part required to support your equipment.

7. HOW TO LOCATE REPAIR PARTS

a. When National stock numbers or part numbers are not known.

(1) *First.* Using the table of contents, determine the assembly group or subassembly group to which the item belongs. This is necessary since figures are prepared for assembly groups and subassembly groups, and listings are divided into the same groups.

(2) *Second.* Find the figure covering the assembly group or subassembly group to which the item belongs.

(3) *Third.* Identify the item on the figure and note the item number.

(4) Fourth. Refer to the Repair Parts Lists for the figure and item numbers. The NSNs and part numbers are on the same line as the associated item numbers.

b. When National stock number or part number is known.

(1) First. If you have the national stock number, look in the STOCK NUMBER column of the National Stock Number Index. The NSN is arranged in national item identification number (NIIN) sequence (see paragraph 4a). Note the figure and item number next to the NSN.

(2) Second. Turn to the figure and locate the item number. Verify that the item is the one you are looking for.

NOTE

If you have the part number, look in the PART NUMBER column of the part number index. Identify the figure and item number, look up the item on the figure in Section II.

8. ABBREVIATIONS (if applicable)

<u>Abbreviations</u>	<u>Explanation</u>
----------------------	--------------------

NOTE: Include uncommon abbreviations used in the RPSTL. List/define those not Found in MIL-STD-12.

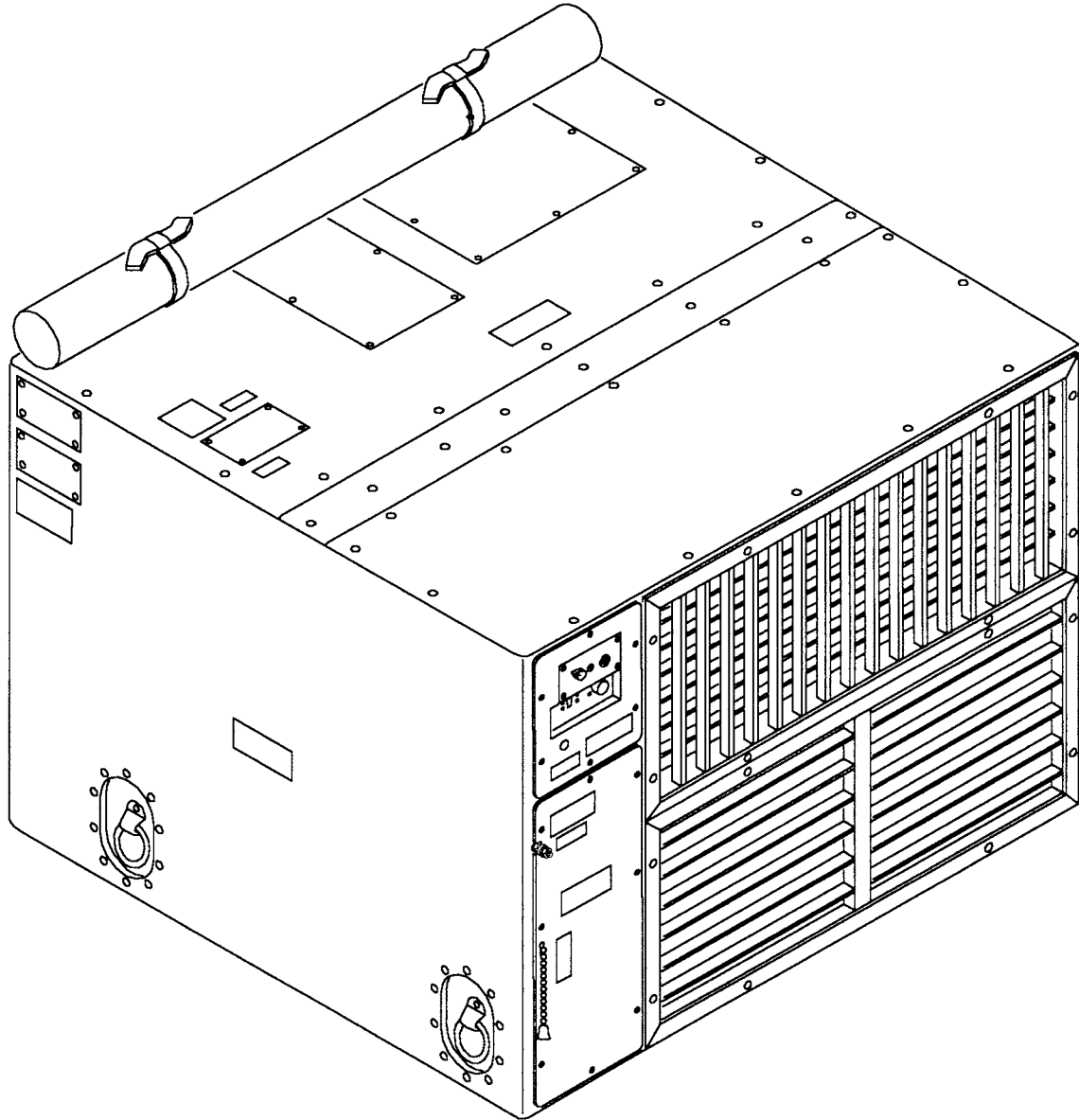

Frontispiece – Air Conditioner, Horizontal, Compact, 36,000 BTU/HR, 208 Volt, Three Phase, 50/60 Hertz

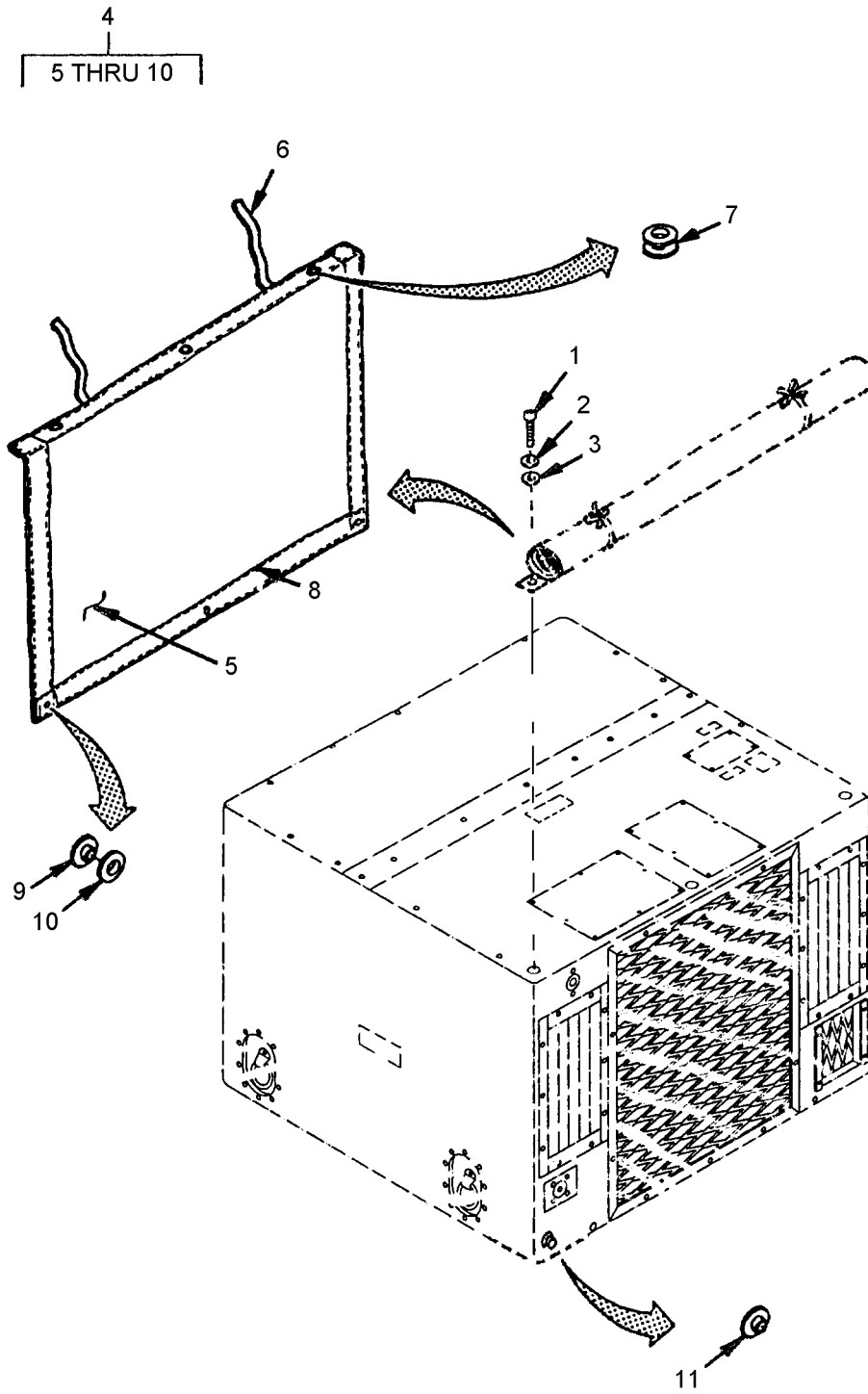

Figure 1. Canvas Cover

SECTION II			TM9-4120-425-14&P			
(1)	(2)	(3)	(4)	(5)	(6)	(7)
ITEM NO	SMR CODE	NSN	CAGEC	PART NUMBER	DESCRIPTION AND USABLE ON CODES(UOC)	QTY
					GROUP 01	CANVAS COVER
FIGURE 1						
1	PAOZZ		96906	MS35207-266	.SCREW, MACHINE	3
2	PAOZZ	5310000453296	96906	MS35338-43	.WASHER, LOCK.....	3
3	PAOZZ	5310000145850	96906	MS27183-42	.WASHER, FLAT.....	3
4	PAOOO		0V5R4	S9500-6361	.COVER, AIR CONDITION.....	1
5	XAOZZ		0V5R4	S9500-6361/1	..CLOTH, COATED.....	1
6	XAOZZ		81349	MIL-W-27265	..WEBBING, TEXTILE.....	2
7	XAOZZ		0V5R4	S9500-6361/3	..GROMMET, METALLIC.....	3
8	XAOZZ		0V5R4	S9500-6361/5	..THREAD, NYLON.....	V
9	XBOZZ	5325002764953	96906	MS27980-1N	..CAP, SNAP FASTENER.....	3
10	XBOZZ	5325002764946	96906	MS27980-6N	..SOCKET, SNAP FASTENE.....	3
11	PAOZZ	5325002764931	96906	MS27980-18N	..STUD, SNAP FASTENER.....	3
12	PAOZZ	5305009586373	96906	MS24693-S51	.SCREW, MACHINE.....	8

END OF FIGURE

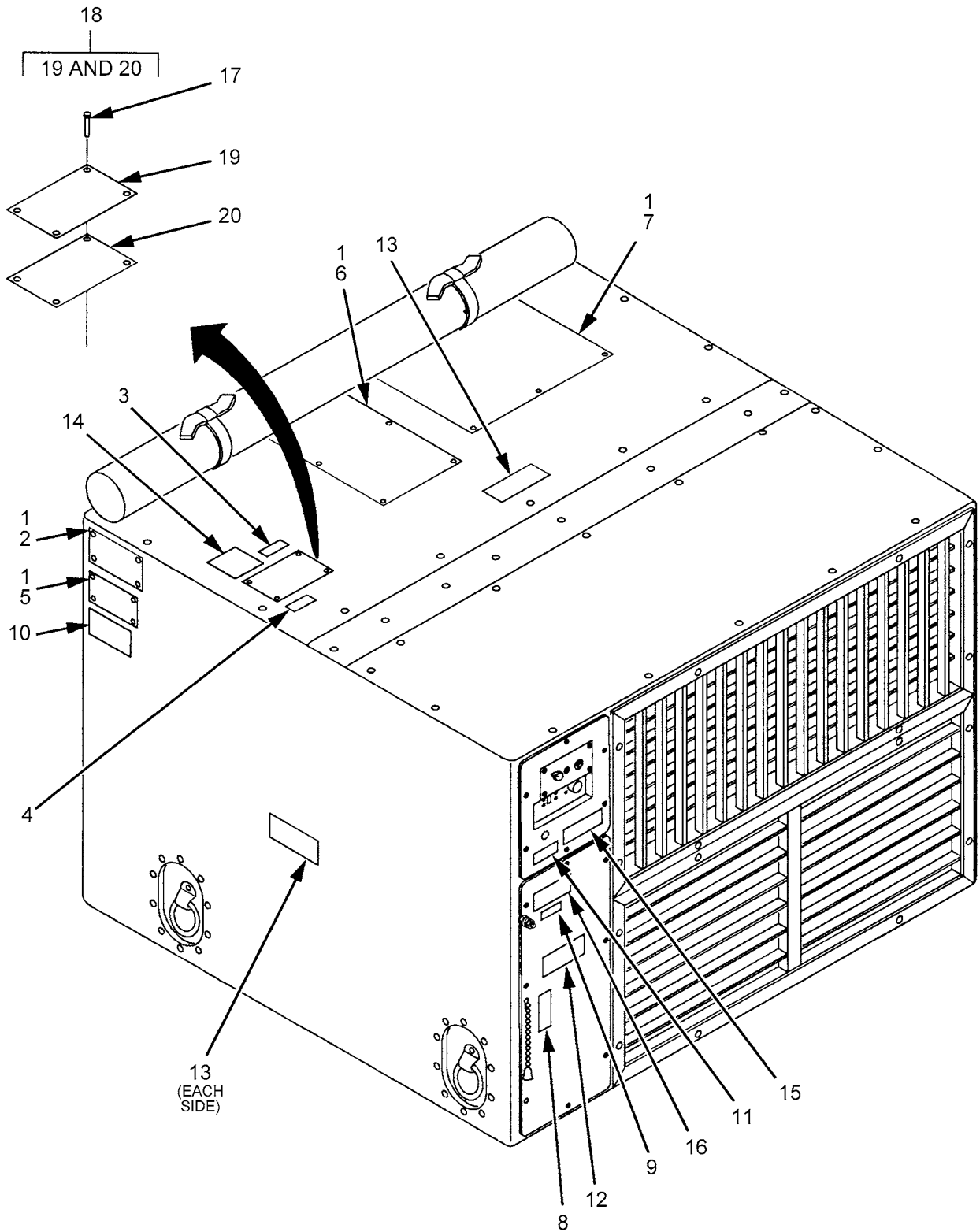

Figure 2. Identification Plates

SECTION II TM9-4120-425-14&P

(1)	(2)	(3)	(4)	(5)	(6)	(7)
ITEM NO	SMR CODE	NSN	CAGEC	PART NUMBER	DESCRIPTION AND USABLE ON CODES(UOC)	QTY
					GROUP 02 IDENTIFICATION PLATES	

FIGURE 2

1	PAOZZ	5320001196754	96906	MS20470AD2-3	.RIVET,SOLID 1/16 DIA ALUMINUM.....	20
2	XBOZZ		0V5R4	S9500-6179-1	.PLATE,IDENT.....	1
3	XBOZZ		97403	13218E6957	.PLATE,INSTRUCTION HIGH PRESSURE CHARGING VALVE.....	1
4	XBOZZ		97403	13218E6958	.PLATE,INSTRUCTION LOW PRESSURE CHARGING VALVE.....	1
5	XBOZZ		0V5R4	S9500-6179-2	.PLATE,INSTRUCTION WARRANTY.....	1
6	XBOZZ		0V5R4	S9500-6697	.PLATE,INSTRUCTION FLUID DIAGRAM...	1
7	XBOZZ		0V5R4	S9500-6699	.DIAGRAM,SCHEMATIC.....	1
8	XBOZZ		0V5R4	S9500-5864-2	.PLATE,INSTRUCTION VENT CLOSED.....	1
9	XBOZZ		0V5R4	S9500-5864-1	.PLATE,DESIGNATION, GROUND.....	1
10	XBOZZ		0V5R4	S9500-4231-1	.PLATE,INSTRUCTION, CAUTION.....	1
11	XBOZZ		0V5R4	S8450-2	.PLATE,INSTRUCTION, RESET HIGH PRESSURE.....	1
12	XBOZZ		0V5R4	S9500-7548	.PLATE,DANGER.....	1
13	XBOZZ		0V5R4	S9500-6958	.PLATE,INSTRUCTION MECHANICAL LIFT CAUTION.....	3
14	XBOZZ		0V5R4	S9500-6180	.PLATE,INSTRUCTION CHEMICAL SUBSTANCE WARNING.....	1
15	XBOZZ		0V5R4	S9500-2-15	.PLATE,INSTRUCTION, CAUTION, 208 VOLTS.....	1
16	XBOZZ		0V5R4	S9500-2-16	.PLATE,INSTRUCTION, CAUTION, CONNECT GROUND.....	1
17	PAOZZ	5305009586373	96906	MS24693-S51	.SCREW,MACHINE.....	4
18	XBOOO		0V5R4	S9500-8423	.COVER,ACCESS, CHARGING VALVE.....	1
19	XBOZZ		0V5R4	S9500-8423/1	..COVER CHARGING VALVE.....	1
20	MOOZZ		0V5R4	S9500-2-18	..INSULATION,THERMAL MAKE FROM INSULATION, P/N ASTM-C534TP2X, .060THK.....	1

END OF FIGURE

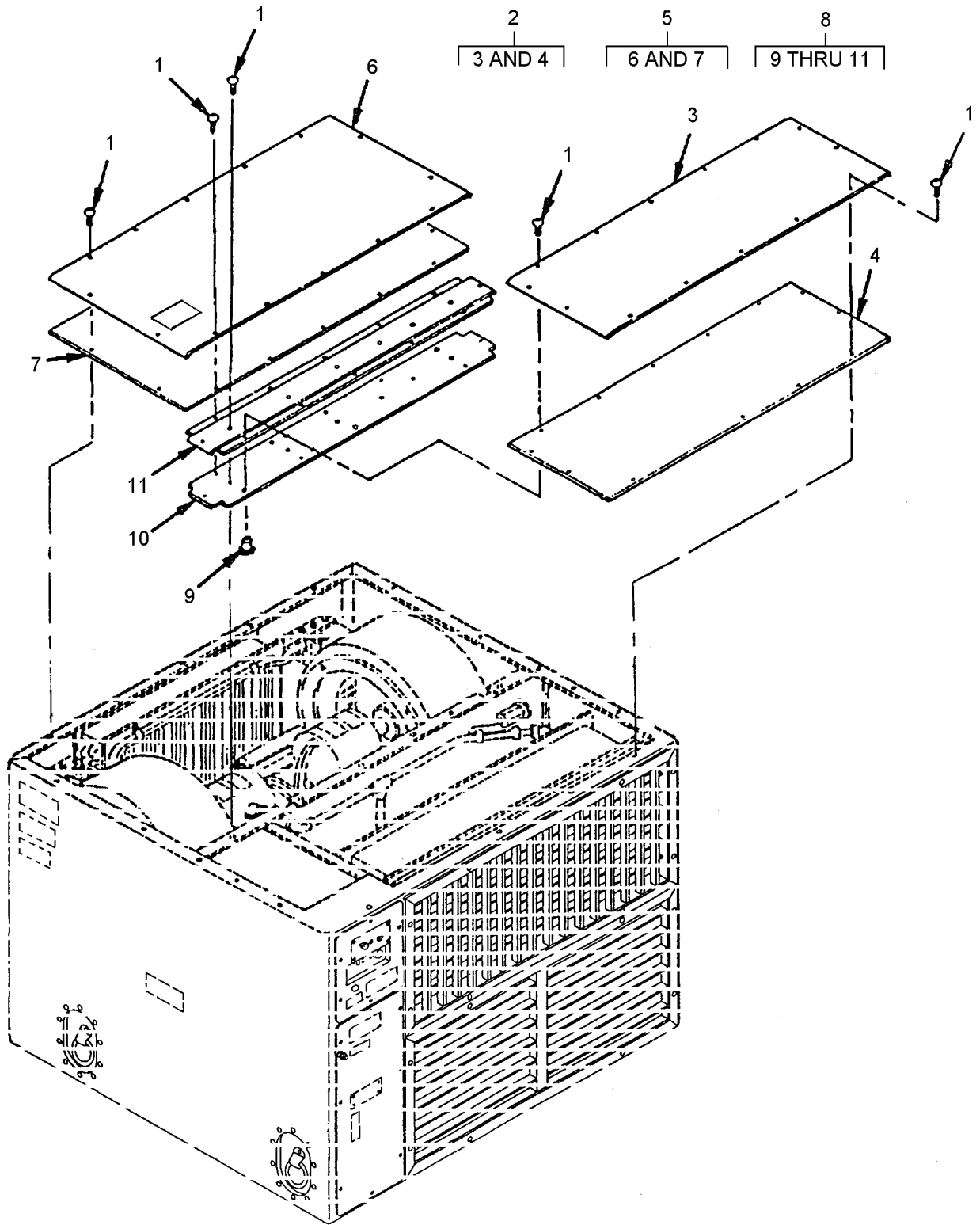

Figure 3. Panels and Covers

SECTION II			TM9-4120-425-14&P			
(1)	(2)	(3)	(4)	(5)	(6)	(7)
ITEM	SMR			PART		
NO	CODE	NSN	CAGEC	NUMBER	DESCRIPTION AND USABLE ON CODES(UOC)	QTY
GROUP 02 PANELS AND COVERS						
FIGURE 3						
1	PAOZZ	5305000633507	96906	MS24693-S274	.SCREW,MACHINE.....	33
2	XBOOO		0V5R4	S9500-6314	.PANEL,FRONT COVER.....	1
3	XAOZZ		0V5R4	S9500-6314-1	..COVER.....	1
4	MOOZZ		0V5R4	S9500-3-4	..INSULATION,THERMAL MAKE FROM	1
					INSULATION, P/N ASTM-C-534TP2,.25THK	
5	XBOOO		0V5R4	S9500-6282	.PANEL,REAR COVER.....	1
6	XAOZZ		0V5R4	S9500-6282/1	..COVER.....	1
7	MOOZZ		0V5R4	S9500-3-7	..INSULATION,THERMAL MAKE FROM	1
					INSULATION, P/N ASTM-C534TP2,.25THK.	
8	XBOOO		0V5R4	S9500-6695	.PANEL,CENTER COVER.....	1
9	PAOZZ	5310009585321	96906	MS27130-S26K	..NUT,PLAIN,BLIND RIV.....	10
10	MOOZZ		0V5R4	S9500-3-10	..INSULATION,THERMAL MAKE FROM	1
					INSULATION, P/N ASTM-C534TP2,.25THK.	
11	XBOZZ		0V5R4	S9500-6695-1	..COVER.....	1

END OF FIGURE

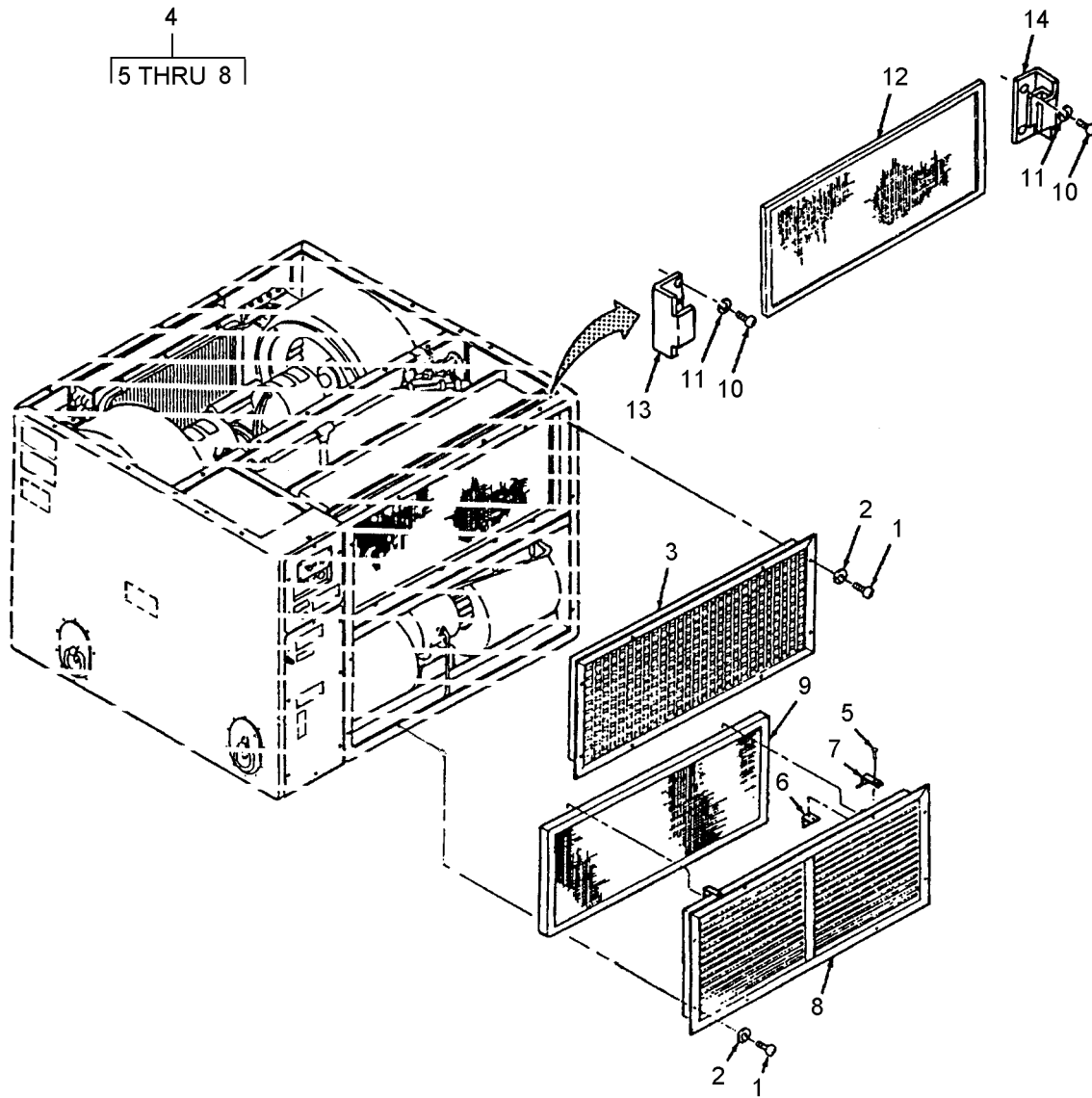

Figure 4. Evaporator Air Louvers, Air Conditioning Filter and Mist Eliminator

SECTION II			TM9-4120-425-14&P			
(1)	(2)	(3)	(4)	(5)	(6)	(7)
ITEM	SMR			PART		
NO	CODE	NSN	CAGEC	NUMBER	DESCRIPTION AND USABLE ON CODES(UOC)	QTY
					GROUP 03 AND 04	EVAPORATOR AIR LOUVERS, AIR CONDITIONING FILTER AND MIST ELIMINATOR
					FIGURE 4	
1	PAOZZ	5305009846194	80205	MS35206-246	.SCREW,MACHINE.....	16
2	PAOZZ	5310000453299	96906	MS35338-42	.WASHER,LOCK.....	16
3	XBOZZ		0V5R4	S9500-6318	.LOUVER,METAL.....	1
4	XBOOO		0V5R4	S9500-6080-5	.LOUVER W/CLIPS.....	1
5	PAOZZ	5320008828385	97403	13214E3789-11	..RIVET,BLIND.....	8
6	XAOZZ		0V5R4	S9500-6080-5/2	..BRACKET,ANGLE.....	4
7	XAOZZ		0V5R4	S9500-6080-5/3	..CLIP.....	4
8	XAOZZ		0V5R4	S9500-6696	..LOUVER,METAL.....	1
9	PAOZZ		82866	97132217	.FILTER,AIR COND.....	1
10	PAOZZ	5305009931848	96906	MS35207-265	.SCREW,MACHINE.....	4
11	PAOZZ	5310000453296	96906	MS35338-43	.WASHER,LOCK.....	4
12	PAOZZ	4130011239112	97403	13219E1032	.FILTER ELEMENT,AIR.....	1
13	XBOZZ		0V5R4	S9500-1031	.BRACKET,MIST ELIMINATOR,RIGHT.....	1
14	XBOZZ		0V5R4	S9500-1030	.BRACKET,MIST ELIMINATOR,LEFT.....	1

END OF FIGURE

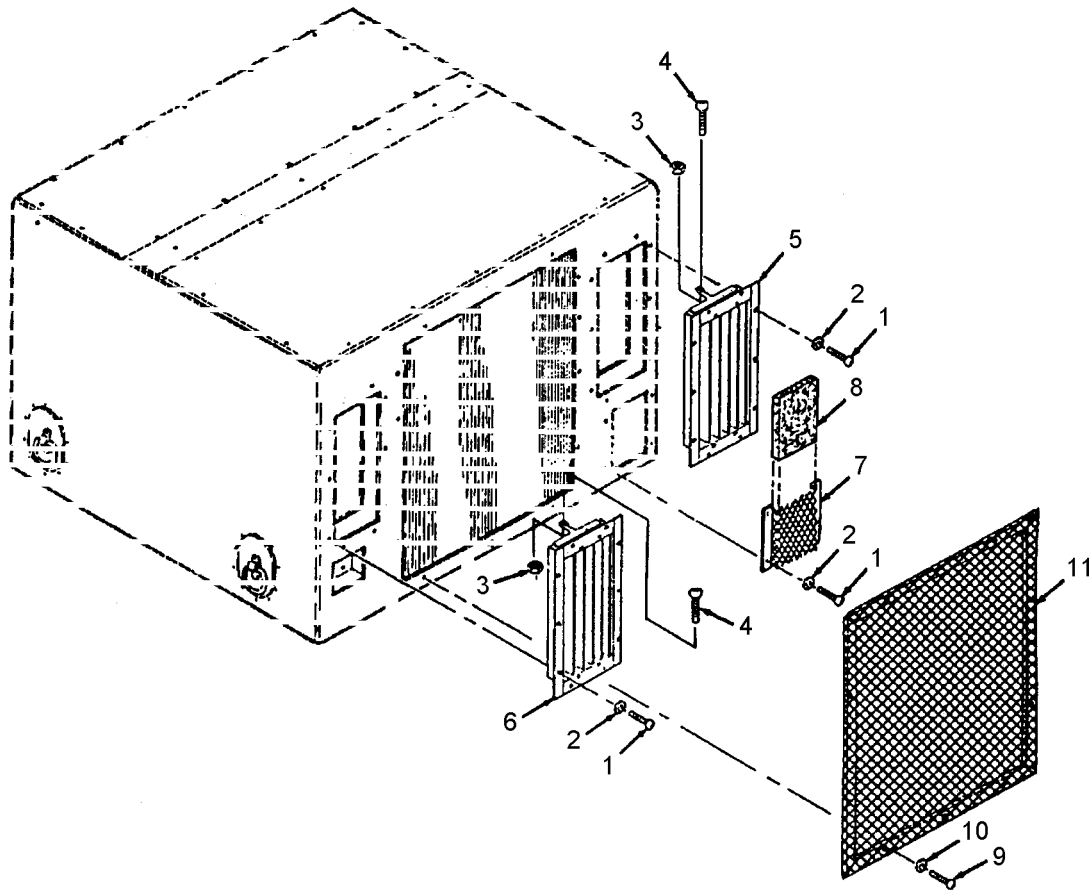

Figure 5. Condenser Exhaust Louvers, Condenser Coil Guard, Ventilation Air Filter and Guard

SECTION II			TM9-4120-425-14&P			
(1)	(2)	(3)	(4)	(5)	(6)	(7)
ITEM NO	SMR CODE	NSN	CAGEC	PART NUMBER	DESCRIPTION AND USABLE ON CODES(UC) QTY	
					GROUP 05 CONDENSER EXHAUST LOUVERS, CONDENSER COIL GUARD, VENTILATION AIR FILTERS AND GUARD	
FIGURE 5						
1	PAOZZ	5305009846194	80205	MS35206-246	.SCREW,MACHINE.....	20
2	PAOZZ	5310000453299	96906	MS35338-42	.WASHER,LOCK.....	20
3	PAOZZ	5310008775797	96906	MS21044N3	.NUT,SELF-LOCKING,HE.....	2
4	PAOZZ	5305009897435	96906	MS35207-264	.SCREW,MACHINE.....	2
5	XBOOO		0V5R4	S9500-9520	.LOUVER ASSEMBLY RIGHT. SEE FIG. 7 FOR ASSY BRKDN.....	1
6	XBOOO		0V5R4	S9500-9521	.LOUVER ASSEMBLY LEFT. SEE FIG. 6 FOR ASSY BRKDN.....	1
7	XBOZZ		0V5R4	S9500-6316	.GUARD,VENTILATION.....	1
8	PAOZZ		82866	97132219	.FILTER MEDIA,AIR CO.....	1
9	PAOZZ	5305009953444	96906	MS35207-266	.SCREW,MACHINE.....	10
10	PAOZZ	5310000453296	96906	MS35338-43	.WASHER,LOCK.....	10
11	XBOZZ		0V5R4	S9500-9514	.GUARD,CONDENSER.....	1

END OF FIGURE

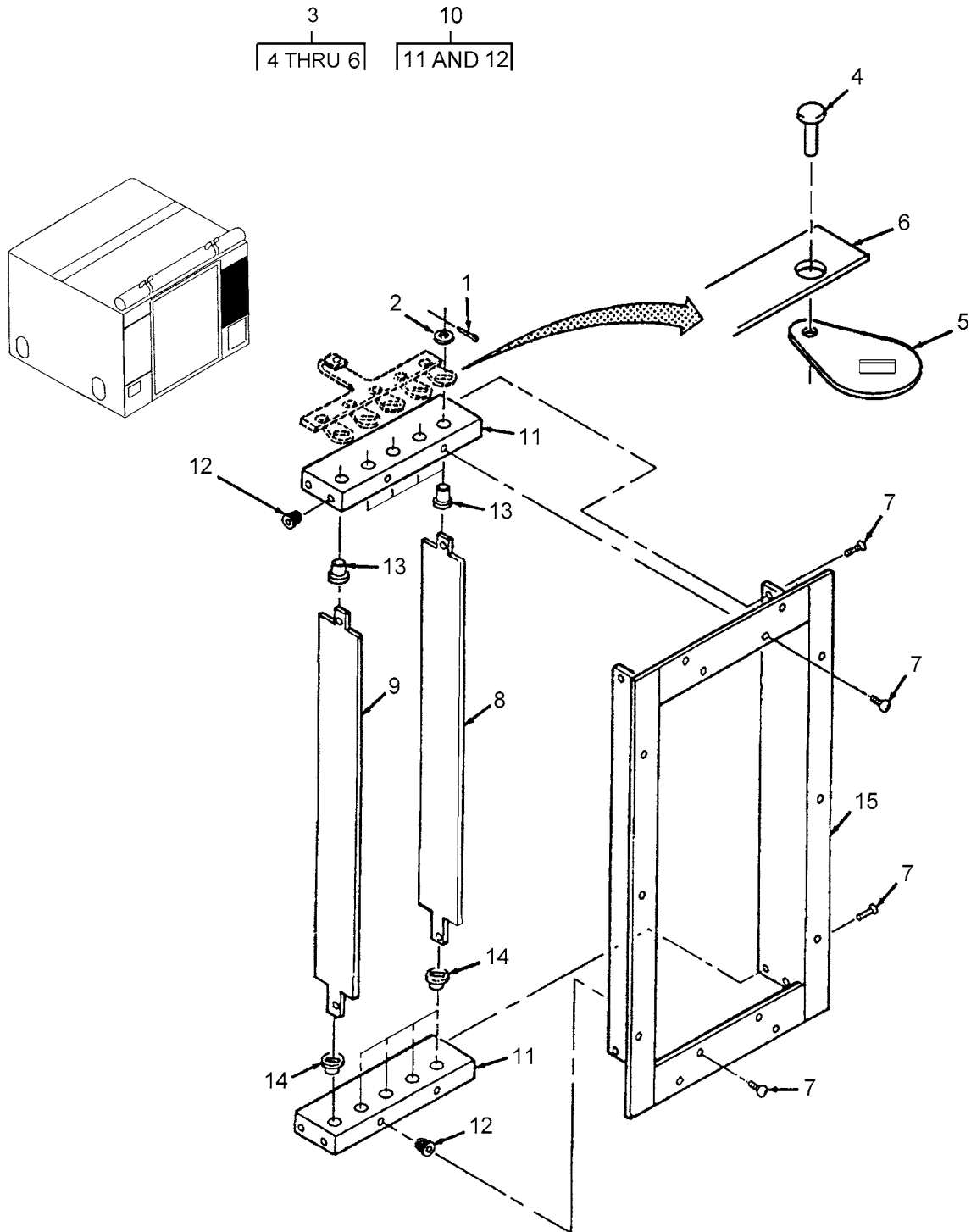

Figure 6. Condenser Air Exhaust Louver Assembly (Left)

SECTION II			TM9-4120-425-14&P			
(1)	(2)	(3)	(4)	(5)	(6)	(7)
ITEM	SMR			PART		
NO	CODE	NSN	CAGEC	NUMBER	DESCRIPTION AND USABLE ON CODES(UOC)	QTY
					GROUP 05 CONDENSER AIR EXHAUST	
					LOUVER ASSEMBLY (LEFT)	

FIGURE 6

1	PAOZZ	5315008151405	96906	MS24665-151	.PIN,COTTER.....	5
2	PAOZZ	5310004041433	96906	MS17188-1	.WASHER,FLAT.....	5
3	XAOZZ		0V5R4	S9500-9518	.CONNECTING LINK/ARM.....	1
4	PAOZZ	5320008796606	96906	MS16535-154	..RIVET,TUBULAR.....	5
5	XAOZZ		0V5R4	S9500-9528	..ARM,LOUVER BLADE.....	5
6	XAOZZ		0V5R4	S9500-9529	..LINK.....	1
7	PAOZZ	5305009577817	96906	MS24693-S26	.SCREW,MACHINE.....	12
8	PAOZZ		0V5R4	S9500-9524-1	.BLADE,LOUVER.....	1
9	PAOZZ		0V5R4	S9500-9525-2	.BLADE,LOUVER.....	1
10	XAOZZ		0V5R4	S9500-9523	.PLATE,BEARING.....	2
11	XAOZZ		0V5R4	S9500-9523/1	..PLATE.....	1
12	PAOZZ	5325005588826	96906	MS21209C0620	..INSERT,SCREW THREAD.....	6
13	PAOZZ	3110010286817	97403	13216E6103-1	.BEARING,LOUVER BLAD UPPER.....	5
14	PAOZZ	3110010286816	97403	13216E6103-2	.BEARING,LOUVER BLAD LOWER.....	5
15	XAOZZ		0V5R4	S9500-9522	.FRAME,LOUVER.....	1

END OF FIGURE

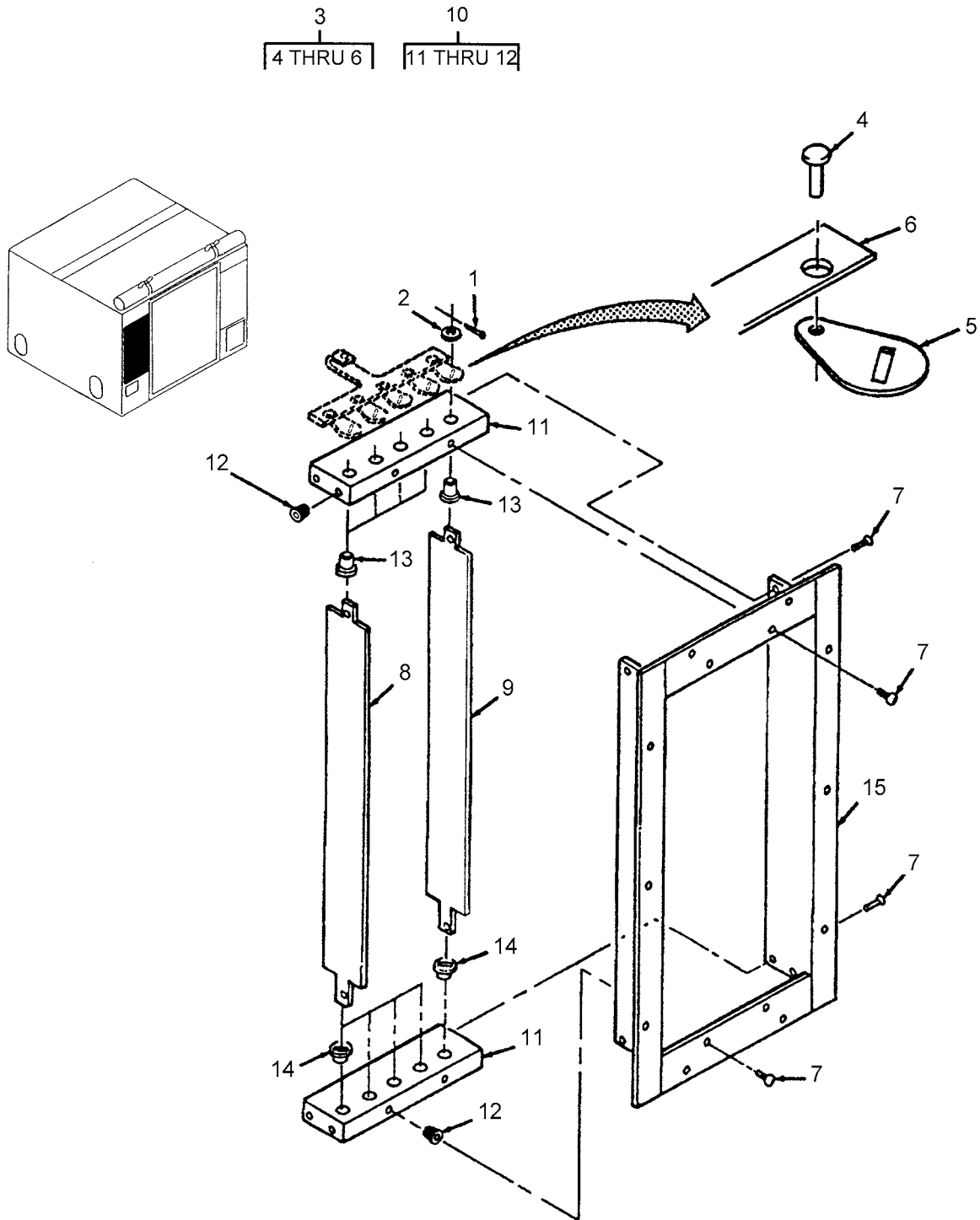

Figure 7. Condenser Air Exhaust Louver Assembly (Right)

SECTION II			TM9-4120-425-14&P			
(1)	(2)	(3)	(4)	(5)	(6)	(7)
ITEM NO	SMR CODE	NSN	CAGEC	PART NUMBER	DESCRIPTION AND USABLE ON CODES(UOC)	QTY

GROUP 05 CONDENSER AIR EXHAUST
LOUVER ASSEMBLY (RIGHT)

FIGURE 7

1	PAOZZ	5315008151405	96906	MS24665-151	.PIN,COTTER.....	5
2	PAOZZ	5310004041433	96906	MS17188-1	.WASHER,FLAT.....	5
3	XAOZZ		0V5R4	S9500-9519	.CONNECTING LINK/ARM.....	1
4	PAOZZ	5320008796606	96906	MS16535-154	..RIVET,TUBULAR.....	5
5	XAOZZ		0V5R4	S9500-9528	..ARM,LOUVER BLADE.....	5
6	XAOZZ		0V5R4	S9500-9529	..LINK.....	1
7	PAOZZ	5305009577817	96906	MS24693-S26	.SCREW,MACHINE.....	12
8	PAOZZ		0V5R4	S9500-9525-2	.BLADE,LOUVER.....	4
9	PAOZZ		0V5R4	S9500-9524-1	.BLADE,LOUVER.....	1
10	XAOZZ		0V5R4	S9500-9523	.PLATE,BEARING.....	2
11	XAOZZ		0V5R4	S9500-9523/1	..PLATE.....	1
12	PAOZZ	5325005588826	96906	MS21209C0620	..INSERT,SCREW THREAD.....	6
13	PAOZZ	3110010286817	97403	13216E6103-1	.BEARING,LOUVER BLAD UPPER.....	5
14	PAOZZ	3110010286816	97403	13216E6103-2	.BEARING,LOUVER BLAD LOWER.....	5
15	XAOZZ		0V5R4	S9500-9522	.FRAME,LOUVER.....	1

END OF FIGURE

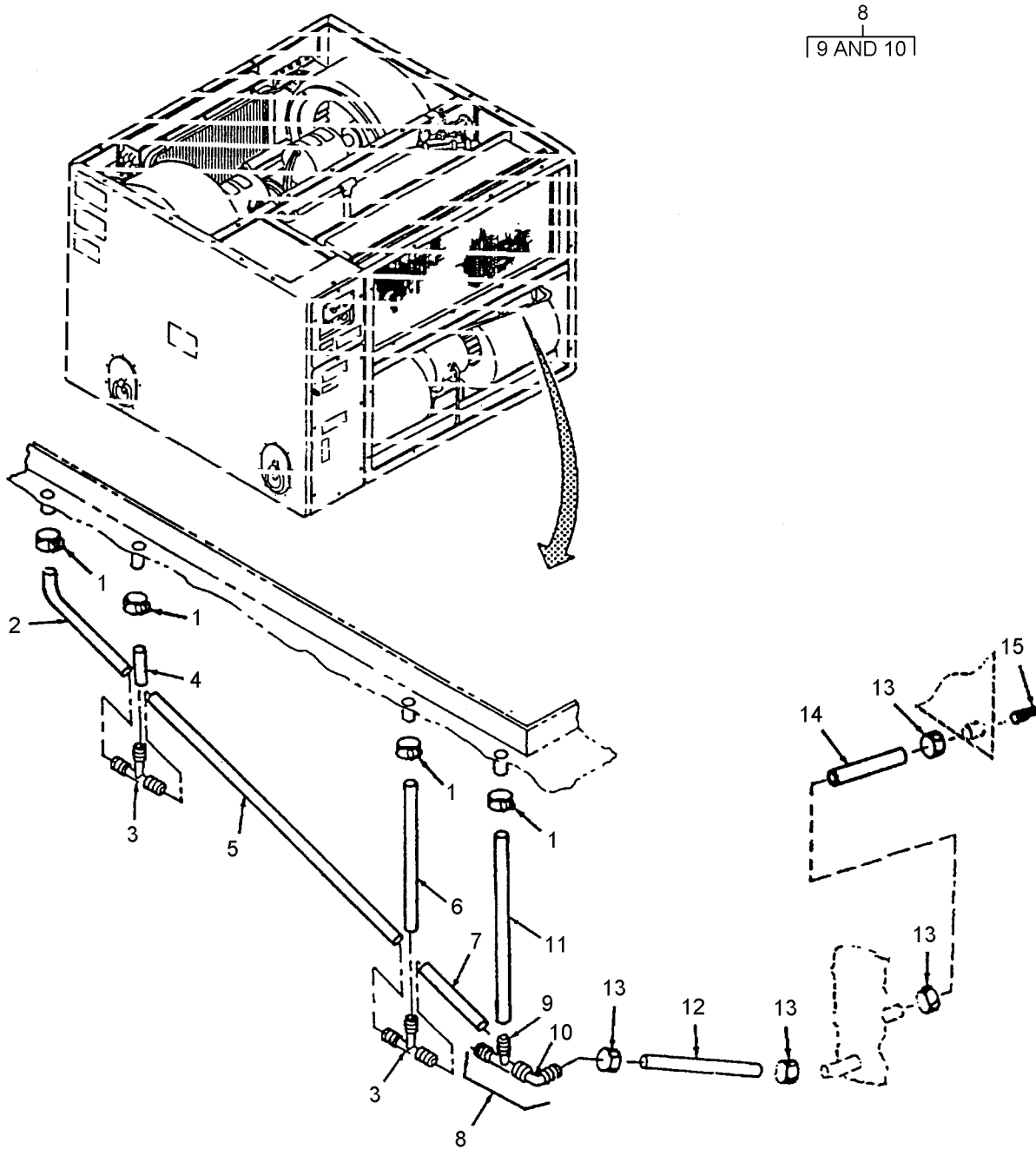

Figure 8. Condensate Drain

SECTION II			TM9-4120-425-14&P			
(1)	(2)	(3)	(4)	(5)	(6)	(7)
ITEM NO	SMR CODE	NSN	CAGEC	PART NUMBER	DESCRIPTION AND USABLE ON CODES(UOC)	QTY
					GROUP 06 CONDENSATE DRAIN ASSEMBLY	
					FIGURE 8	
1	PAOZZ		96906	MS35842-10	.CLAMP,HOSE.....	4
2	MOOZZ		0V5R4	S9500-6700/273	.TUBING MAKE FROM TUBE, P/N ZZ-T-831, TYPE VI, CLASS 6.....	1
3	PAOZZ		87373	P6TUB6	.TEE,PIPE.....	2
4	MOOZZ		0V5R4	S9500-6700/275	.TUBING MAKE FROM TUBE, P/N ZZ-T-831, TYPE VI, CLASS 6.....	1
5	MOOZZ		0V5R4	S9500-6700/276	.TUBING MAKE FROM TUBE, P/N ZZ-T-831, TYPE VI, CLASS 6.....	1
6	MOOZZ		0V5R4	S9500-6700/277	.TUBING MAKE FROM TUBE, P/N ZZ-T-831, TYPE VI, CLASS 6.....	1
7	MOOZZ		0V5R4	S9500-6700/278	.TUBING MAKE FROM TUBE, P/N ZZ-T-831, TYPE VI, CLASS 6.....	1
8	PAOZZ	4730014759640	97403	13229E5334	.COUPLING ASSEMBLY,T.....	1
9	XAOZZ		87373	P8TUB8	..TEE,PIPE.....	1
10	XAOZZ		87373	P8EUB8	..ELBOW,PIPE.....	1
11	MOOZZ		0V5R4	S9500-6700/280	.TUBING MAKE FROM TUBE, P/N ZZ-T-831, TYPE VI, CLASS 6.....	1
12	MOFZZ		0V5R4	S9500-6700/282	.TUBING MAKE FROM TUBE, P/N ZZ-T-831, TYPE VI, CLASS 6.....	1
13	PAFZZ	4730009083194	96906	MS35842-11	.CLAMP,HOSE.....	4
14	MOFZZ		0V5R4	S9500-6700/292	.TUBING MAKE FROM TUBE, P/N ZZ-T-831, TYPE VI, CLASS 6.....	1
15	PAFZZ		81348	WW-P-471,TY III, STY A	.PIPE FITTING,ASSORT.....	1

END OF FIGURE

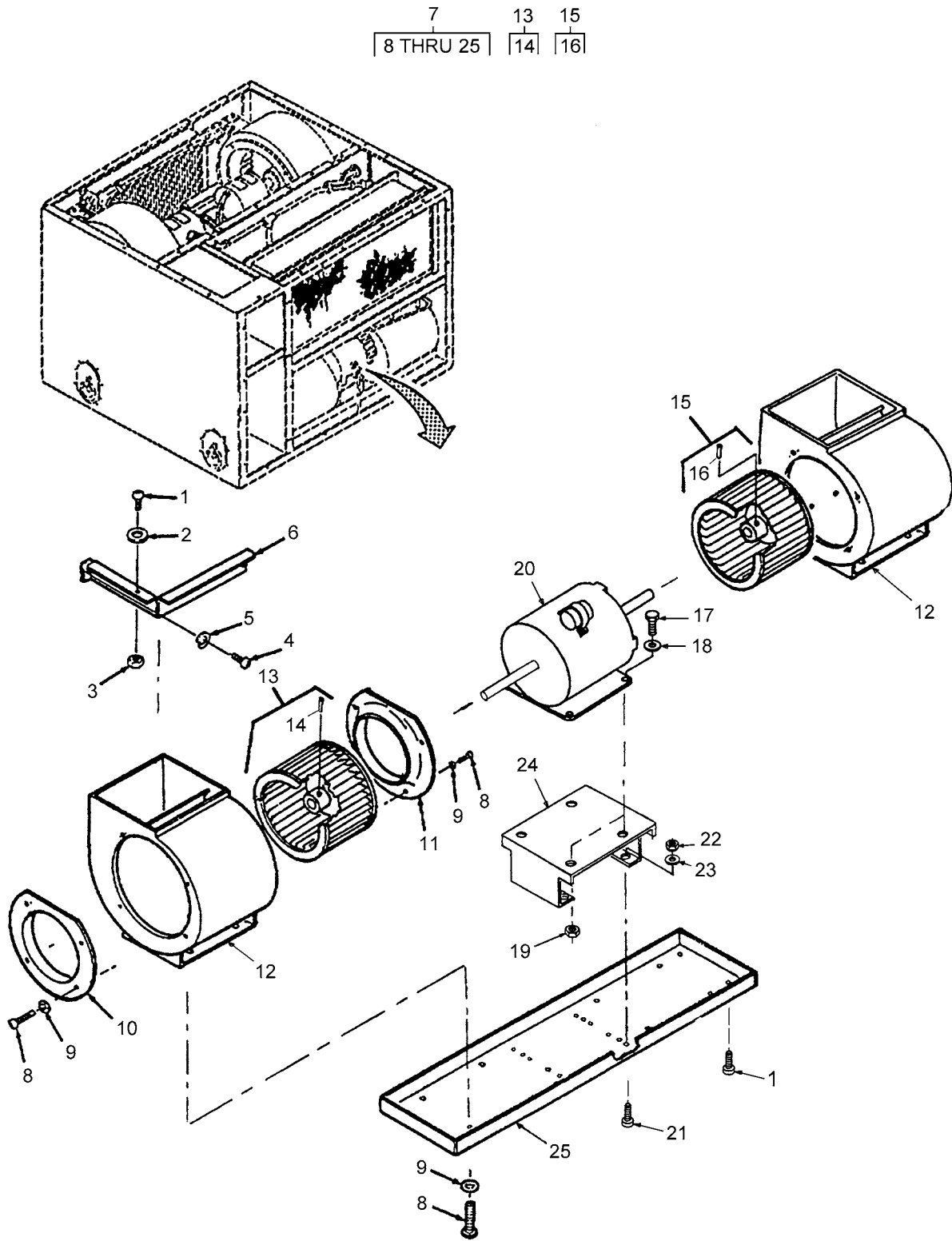

Figure 9. Evaporator Fan Assembly

SECTION II			TM9-4120-425-14&P			
(1)	(2)	(3)	(4)	(5)	(6)	(7)
ITEM NO	SMR CODE	NSN	CAGEC	PART NUMBER	DESCRIPTION AND USABLE ON CODES(UOC)	QTY

GROUP 07 EVAPORATOR FAN ASSEMBLY

FIGURE 9

1	PAFZZ	5305009897435	96906	MS35207-264	.SCREW,MACHINE.....	6
2	PAFZZ	5310000145850	96906	MS27183-42	.WASHER,FLAT.....	2
3	PAFZZ	5310008775797	96906	MS21044N3	.NUT,SELF-LOCKING,HE.....	2
4	PAFZZ	5305009931848	96906	MS35207-265	.SCREW,MACHINE.....	4
5	PAFZZ	5310000453296	96906	MS35338-43	.WASHER,LOCK.....	4
6	XBFZZ		0V5R4	S9500-9542	.DUCT,SCROLL.....	2
7	PAFFF		0V5R4	S9500-7867	.EVAPORATOR FAN ASSY.....	1
8	PAFZZ	5305009846192	96906	MS35206-244	..SCREW,MACHINE.....	24
9	PAFZZ	5310007653197	96906	MS27183-41	..WASHER,FLAT.....	24
10	XBFZZ		0V5R4	S9500-3543	..BELL,INLET.....	2
11	XBFZZ		0V5R4	S9500-3543	..BELL,INLET.....	2
12	XBFZZ		0V5R4	S9500-9543	..SCROLL,EVAPORATOR.....	2
13	PAFZZ		0V5R4	S9500-6354	..IMPELLER,FAN,CENTRI CW. (INCLUDES SETSCREW).....	1
14	PAFZZ		0V5R4	S9500-10-14	...SETSCREW.....	1
15	PAFZZ		0V5R4	S9500-6355	..IMPELLER,FAN,CENTRI CCW. (INCLUDES SETSCREW).....	1
16	PAFZZ		0V5R4	S9500-10-16	...SETSCREW.....	1
17	PAFZZ		96906	MS24693-118	..SCREW,MACHINE.....	4
18	PAFZZ	5310000814219	96906	MS27183-12	..WASHER,FLAT.....	4
19	PAFZZ	5310000880553	96906	MS21044N5	..NUT,SELF-LOCKING,HE.....	4
20	PAFZZ		0V5R4	S9500-6671	..MOTOR,ALTERNATING C.....	1
21	PAFZZ		96906	MS24693-304	..SCREW,MACHINE.....	4
22	PAFZZ	5310008775796	96906	MS21044N4	..NUT,SELF-LOCKING,HE.....	4
23	PAFZZ	5310008094058	96906	MS27183-10	..WASHER,FLAT.....	4
24	XBFZZ		0V5R4	S9500-9541	..BRACKET.....	1
25	XBFZZ		0V5R4	S9500-9540	..CHASSIS.....	1

END OF FIGURE

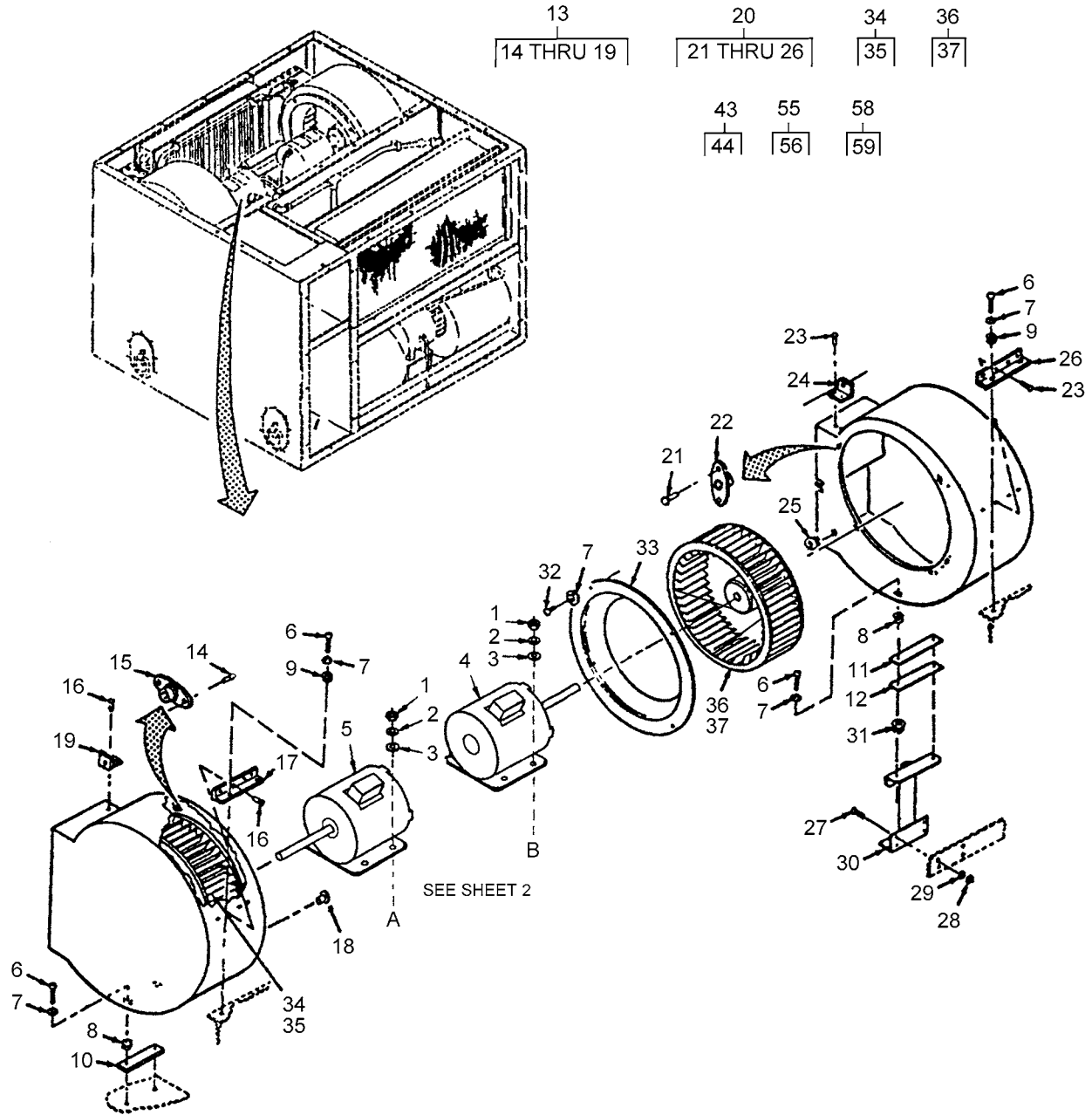

Figure 10. Condenser Fan (Sheet 1 of 2)

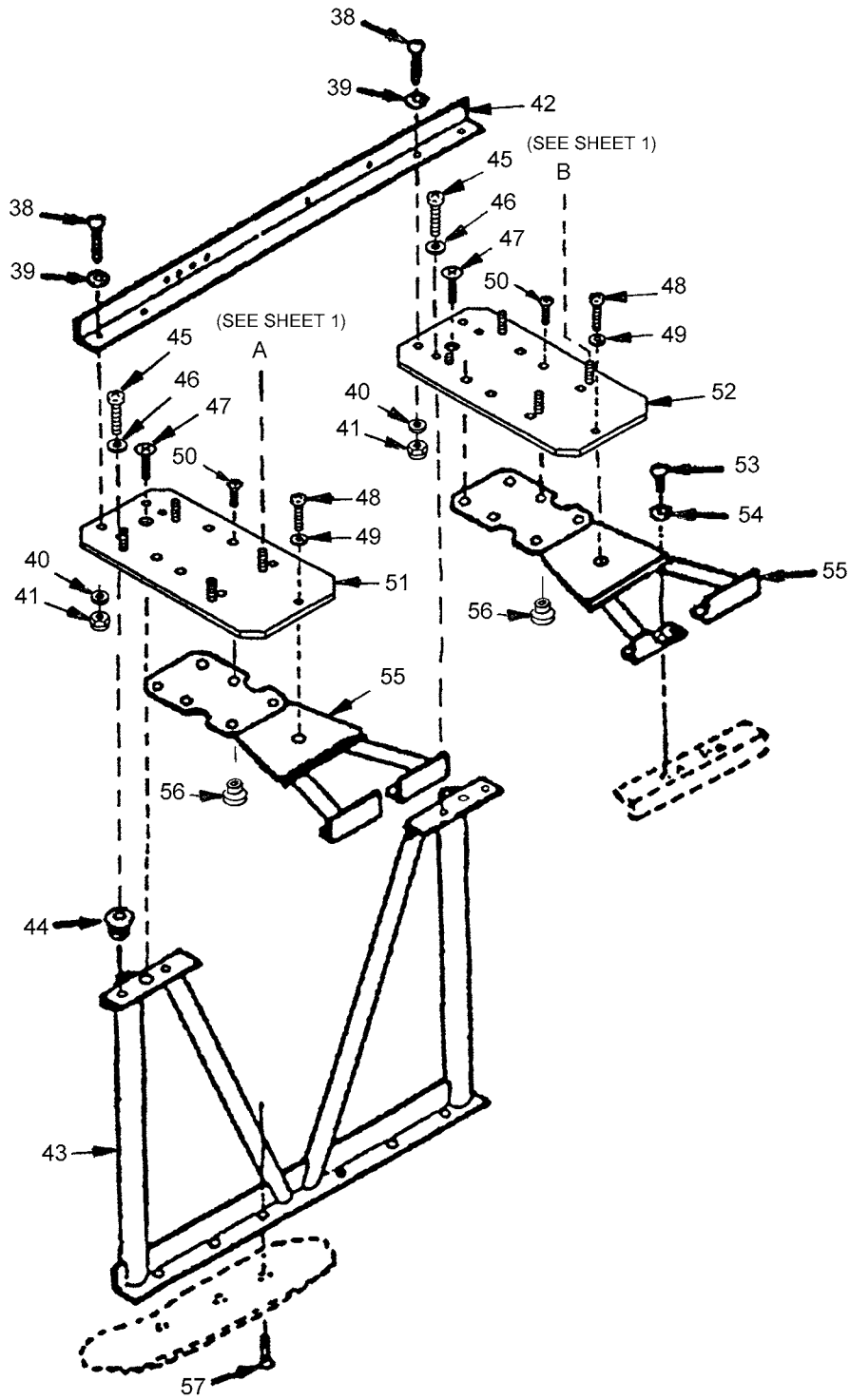

Figure 10. Condenser Fan (Sheet 2 of 2)

SECTION II			TM9-4120-425-14&P			
(1)	(2)	(3)	(4)	(5)	(6)	(7)
ITEM	SMR			PART		
NO	CODE	NSN	CAGEC	NUMBER	DESCRIPTION AND USABLE ON CODES(UOC)	QTY

GROUP 07 CONDENSER FAN

FIGURE 10

1	PAOZZ	5310000880553	96906	MS21044N5	.NUT, SELF-LOCKING, HE.....	8
2	PAOZZ	5310004079566	96906	MS35338-45	.WASHER, LOCK.....	8
3	PAOZZ	5310001670767	88044	AN970-5	.WASHER, FLAT.....	8
4	PAFZZ		0V5R4	S9500-4276CCW	.MOTOR, ALTERNATING CURRENT, CCW....	1
5	PAFZZ		0V5R4	S9500-4276CW	.MOTOR, ALTERNATING CURRENT, CW....	1
6	PAFZZ	5305009846196	96906	MS35206-248	.SCREW, MACHINE.....	8
7	PAFZZ	5310008098544	96906	MS27183-7	.WASHER, FLAT.....	8
8	PAFZZ	5325001745317	96906	MS35489-4	.GROMMET, NONMETALLIC.....	4
9	PAFZZ	5325001850017	96906	MS35489-33	.GROMMET, NONMETALLIC.....	4
10	XBFZZ		0V5R4	S9500-9555	.SPACER .188 IN. THK.....	1
11	XBFZZ		0V5R4	S9500-5338-1	.SPACER .063 IN. THK.....	V
12	XBFZZ		0V5R4	S9500-5338-2	.SPACER .125 IN. THK.....	V
13	XBFZZ		0V5R4	S9500-9516	.SCROLL, CONDENSER.....	1
14	PAFZZ	5320008744477	97403	13214E3791-2	..RIVET, BLIND.....	8
15	PAFZZ	5310007775787	96906	MS21059-L08	..NUT, SELF-LOCKING, PL.....	4
16	PAFZZ	5320001176828	96906	MS20470AD4-6	..RIVET, SOLID.....	6
17	XAFZZ		0V5R4	S9500-9516/8	..BRACKET.....	1
18	PAFZZ	5310010558419	96906	MS27130-S25K	..NUT, PLAIN, BLIND RIV.....	2
19	XAFZZ		0V5R4	S9500-9516/4	..BRACKET.....	1
20	XBFZZ		0V5R4	S9500-9517	.SCROLL, CONDENSER.....	1
21	PAFZZ	5320008744477	97403	13214E3791-2	..RIVET, BLIND.....	8
22	PAFZZ	5310007775787	96906	MS21059-L08	..NUT, SELF-LOCKING, PL.....	4
23	PAFZZ	5320001176828	96906	MS20470AD4-6	..RIVET, SOLID.....	6
24	XAFZZ		0V5R4	S9500-9516/4	..BRACKET.....	1
25	PAFZZ	5310010558419	96906	MS27130-S25K	..NUT, PLAIN, BLIND RIV.....	2
26	XAFZZ		0V5R4	S9500-9516/8	..BRACKET.....	1
27	PAFZZ	5305009931848	96906	MS35207-265	.SCREW, MACHINE.....	4
28	PAFZZ	5310008775797	96906	MS21044N3	.NUT, SELF-LOCKING, HE.....	4
29	PAFZZ	5310000145850	96906	MS27183-42	.WASHER, FLAT.....	4
30	XBFZZ		0V5R4	S9500-9544	.SUPPORT, SCROLL.....	1
31	PAFZZ	5310010479470	80205	NAS1330H08K161L	.NUT, SELF-LOCKING, BL.....	2
32	PAFZZ	5305009846195	96906	MS35206-247	.SCREW, MACHINE.....	8
33	XBFZZ		0V5R4	S9500-6358	.BELL, INLET.....	2
34	PAFZZ		0V5R4	S9500-6356	.IMPELLER, FAN, CENTRI CW. (INCLUDES SETSCREW).....	1
35	PAFZZ		0V5R4	S9500-11-35	..SETSCREW.....	2
36	PAFZZ		0V5R4	S9500-6357	.IMPELLER, FAN, CENTRI CCW. (INCLUDES SETSCREW).....	1
37	PAFZZ		0V5R4	S9500-11-37	..SETSCREW.....	2
38	PAOZZ	5305009932459	96906	MS35207-283	.SCREW, MACHINE.....	4
39	PAFZZ	5310005825965	96906	MS35338-44	.WASHER, LOCK.....	4
40	PAOZZ	5310008094058	96906	MS27183-10	.WASHER, FLAT.....	4
41	PAOZZ	5310013133977	96906	MS21076L4N	.NUT, SELF-LOCKING, PL.....	4
42	XBFZZ		0V5R4	S9500-5337	.ANGLE, ACTUATOR MTG.....	1
43	XBFZZ		0V5R4	S9500-9549	.SUPPORT, CONDENSER.....	1
44	PAFZZ	5310013247187	96906	MS27130-S127K	..NUT, PLAIN, BLIND RIV.....	10
45	PAOZZ	5305009897435	96906	MS35207-264	.SCREW, MACHINE.....	4

SECTION II		TM9-4120-425-14&P					
(1)	(2)	(3)	(4)	(5)	(6)	(7)	
ITEM NO	SMR CODE	NSN	CAGEC	PART NUMBER	DESCRIPTION AND USABLE ON CODES(UOC)	QTY	
46	PAOZZ	5310000453296	96906	MS35338-43	.WASHER, LOCK.....	4	
47	PAOZZ	5305007195007	96906	MS51959-83	.SCREW, MACHINE.....	2	
48	PAOZZ	5305009881727	96906	MS35206-283	.SCREW, MACHINE.....	2	
49	PAOZZ	5310005825965	96906	MS35338-44	.WASHER, LOCK.....	2	
50	PAOZZ		96906	MS35249-74	.SCREW, MACHINE.....	12	
51	XBFZZ		0V5R4	S9500-9553	.PLATE, MOTOR MTG.....	1	
52	XBFZZ		0V5R4	S9500-9554	.PLATE, MOTOR MTG.....	1	
53	PAFZZ	5305009931848	96906	MS35207-265	.SCREW, MACHINE.....	8	
54	PAFZZ	5310000453296	96906	MS35338-43	.WASHER, LOCK.....	8	
55	XBFZZ		0V5R4	S9500-9548	.BRACE, CONDENSER MTR.....	2	
56	PAFZZ	5310013247187	96906	MS27130-S127K	..NUT, PLAIN, BLIND RIV.....	14	
57	PAFZZ	5305009655879	96906	MS24693-S275	.SCREW, MACHINE.....	6	

END OF FIGURE

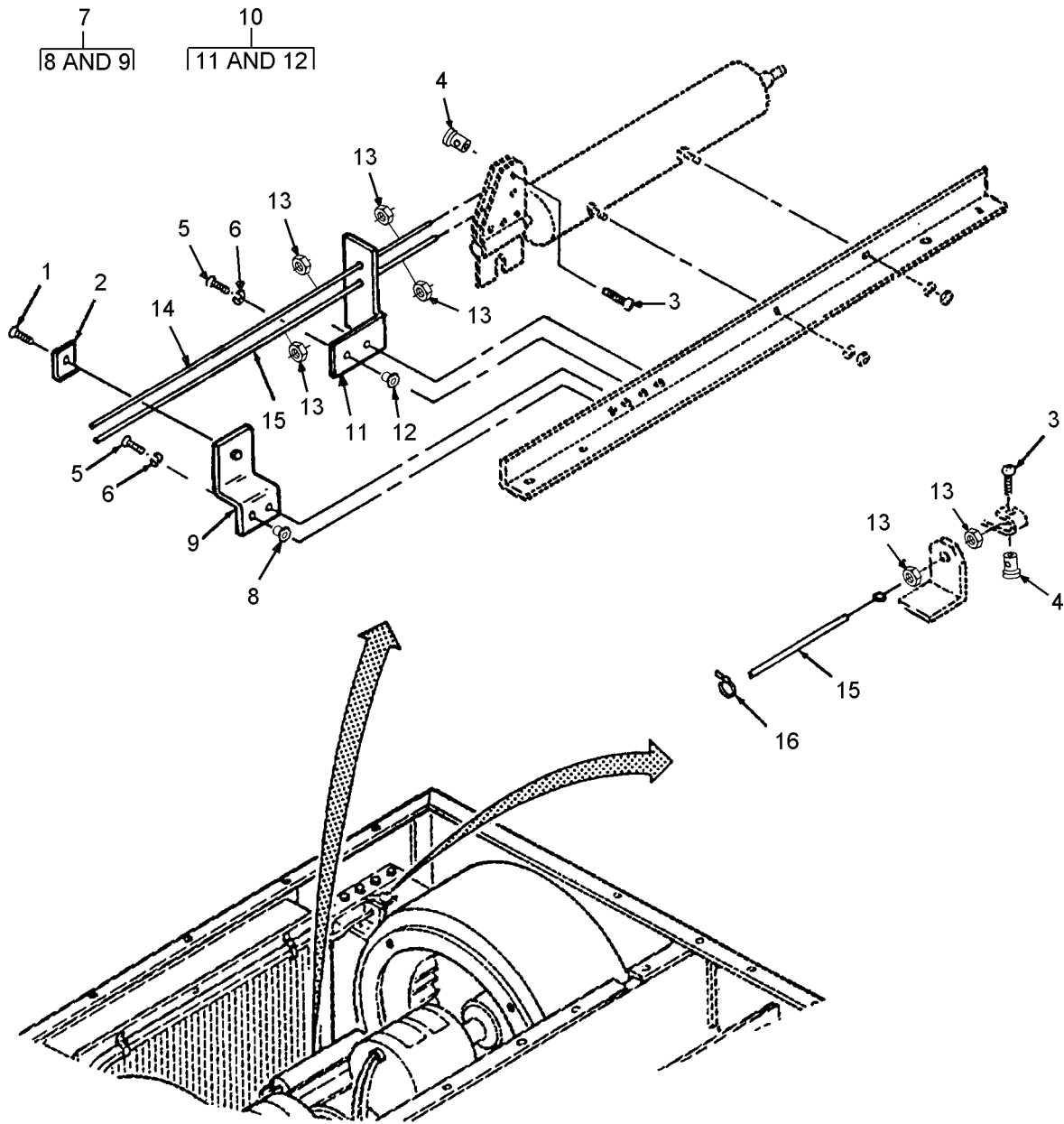

Figure 11. Louver Actuator Cables

SECTION II			TM9-4120-425-14&P			
(1)	(2)	(3)	(4)	(5)	(6)	(7)
ITEM	SMR		PART			
NO	CODE	NSN	CAGEC	NUMBER	DESCRIPTION AND USABLE ON CODES(UOC)	QTY
					GROUP 08 LOUVER ACTUATOR CABLE	

FIGURE 11

1	PAOZZ	5305009846195	96906	MS35206-247	.SCREW,MACHINE.....	1
2	PAOZZ	5340014758943	97403	13225E9509	.CLIP,RETAINING PUSH / PULL.....	1
3	PAOZZ	5305009846191	96906	MS35206-243	.SCREW,MACHINE.....	4
4	XBOZZ	5340011629927	97403	13216E6093-2	.POST,ELECTRICAL-MEC.....	4
5	PAOZZ	5305009846194	80205	MS35206-246	.SCREW,MACHINE.....	4
6	PAOZZ	5310000453299	96906	MS35338-42	.WASHER,LOCK.....	4
7	XBOZZ		0V5R4	S9500-9560	.BRACKET,CABLE CLIP.....	1
8	PAOZZ	5310011469773	96906	MS27130-S94K	..NUT,PLAIN,BLIND RIV.....	2
9	XAOZZ		0V5R4	S9500-9560/1	..BRACKET.....	1
10	XBOZZ		0V5R4	S9500-9508	.BRACKET,CONTROL.....	1
11	XAOZZ		0V5R4	S9500-9508/1	..BRACKET.....	1
12	PAOZZ	5310011469773	96906	MS27130-S94K	..NUT,PLAIN,BLIND RIV.....	2
13	PAOZZ	5310000120560	70436	NT141	.NUT,PLAIN,HEXAGON.....	6
14	PAOZZ	4130010986649	70436	130-032-234	.CONTROL ASSEMBLY,PU PUSH / PULL...	1
15	PAOZZ		70436	130-000-3366	.CONTROL CABLE, PUSH / PULL.....	1
16	PAOZZ	5975001113208	96906	MS3367-5-9	.STRAP,TIEDOWN,ELECT.....	5

END OF FIGURE

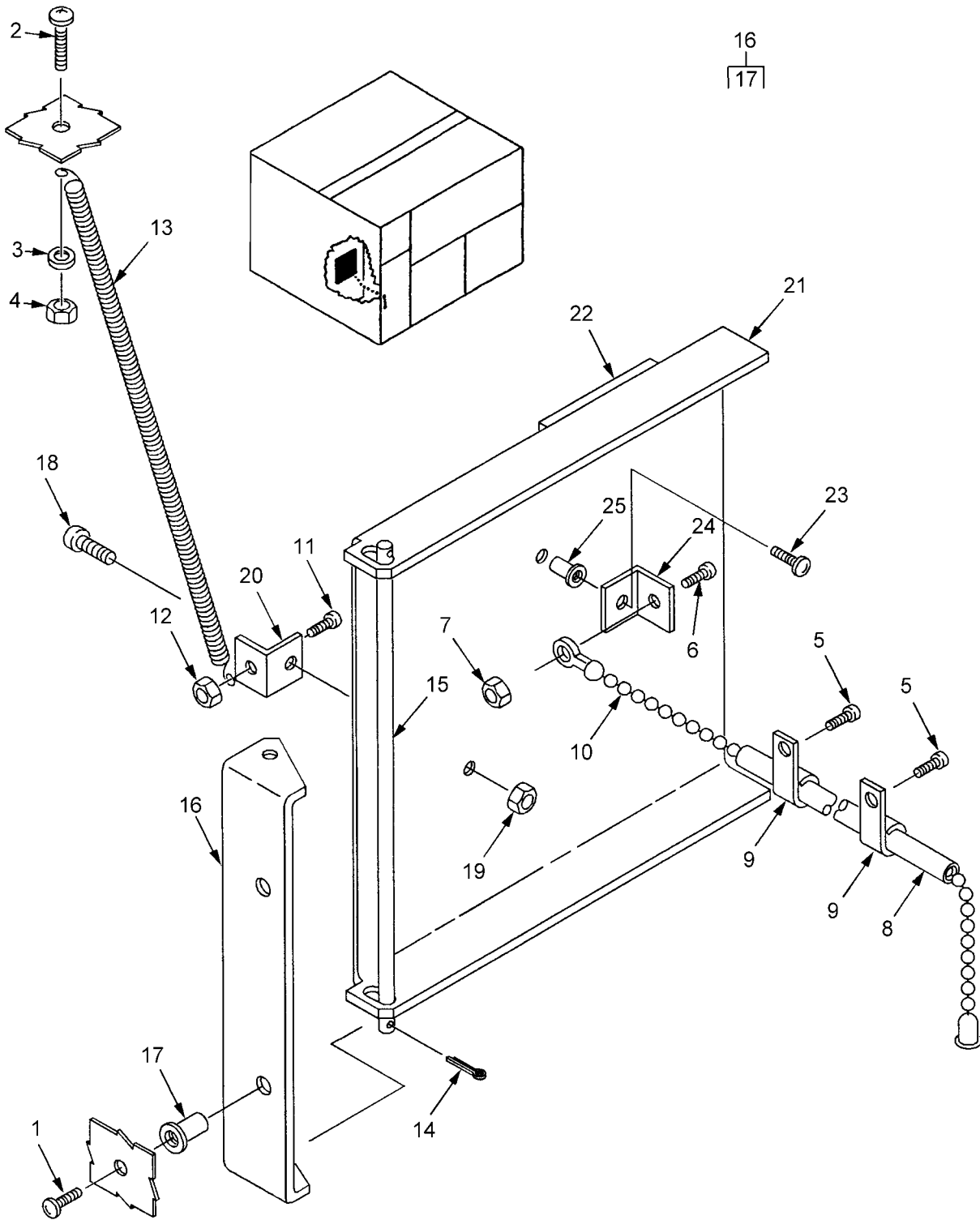

Figure 12. Ventilation Damper

SECTION II		TM9-4120-425-14&P				
(1)	(2)	(3)	(4)	(5)	(6)	(7)
ITEM NO	SMR CODE	NSN	CAGEC	PART NUMBER	DESCRIPTION AND USABLE ON CODES(UOC)	QTY
					GROUP 08 VENTILATION DAMPER	
FIGURE 12						
1	PAFZZ	5305009846194	80205	MS35206-246	.SCREW,MACHINE.....	2
2	PAFZZ	5305009846194	80205	MS35206-246	.SCREW,MACHINE.....	1
3	PAFZZ	5310000453296	96906	MS35338-43	.WASHER,LOCK.....	1
4	PAFZZ	5310008775795	96906	MS21044N8	.NUT,SELF-LOCKING,HE.....	1
5	PAFZZ	5305009846194	80205	MS35206-246	.SCREW,MACHINE.....	2
6	PAFZZ	5305009846193	96906	MS35206-245	.SCREW,MACHINE.....	1
7	PAFZZ	5310008775795	96906	MS21044N8	.NUT,SELF-LOCKING,HE.....	1
8	PAFZZ		0V5R4	S9500-T	.TUBING.....	1
9	PAFZZ	5340005980146	96906	MS21919WDG6	.CLAMP,LOOP.....	2
10	PAFZZ		0V5R4	S9500-CH	.CHAIN.....	1
11	PAFZZ	5305009846193	96906	MS35206-245	.SCREW,MACHINE.....	1
12	PAFZZ	5310008775795	96906	MS21044N8	.NUT,SELF-LOCKING,HE.....	1
13	PAFZZ		0V5R4	S9500-6327-1	.SPRING.....	1
14	PAFZZ	5315008392325	96906	MS24665-132	.PIN,COTTER.....	2
15	PAFZZ		0V5R4	S9500-9970	.SHAFT,DAMPER.....	1
16	PAFZZ		0V5R4	S9500-9971	.HINGE.....	1
17	PAFZZ	5310009585321	96906	MS27130-S26K	.NUT,PLAIN,BLIND RIV.....	2
18	PAFZZ	5305009846193	96906	MS35206-245	.SCREW,MACHINE.....	1
19	PAFZZ	5310008775795	96906	MS21044N8	.NUT,SELF-LOCKING,HE.....	1
20	PAFZZ		0V5R4	S9500-9968	.BRACKET.....	1
21	PAFZZ		0V5R4	S9500-6319	.DAMPER.....	1
22	MOFZZ		0V5R4	S9500-13-22	.INSULATION,THERMAL MAKE FROM INSULATION, P/N ASTM-C534TP2,.500THK	1
23	PAFZZ	5305009846193	96906	MS35206-245	.SCREW,MACHINE.....	1
24	PAFZZ		0V5R4	S9500-9968	.BRACKET.....	1
25	PAFZZ	5310009143290	96906	MS27130-S101K	.NUT,PLAIN,BLIND RIV.....	1

END OF FIGURE

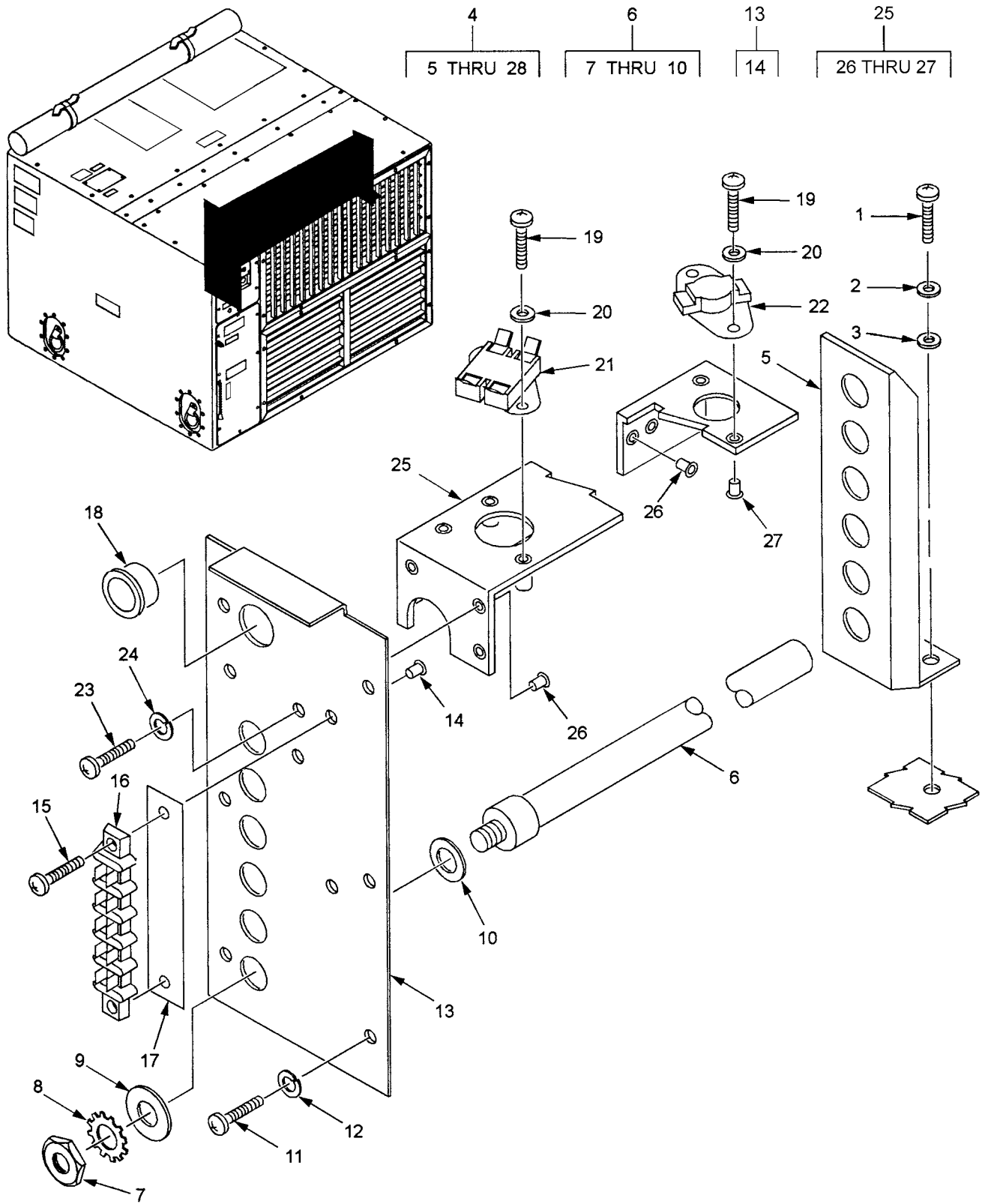

Figure 13. Heater Subassembly

SECTION II			TM9-4120-425-14&P			
(1)	(2)	(3)	(4)	(5)	(6)	(7)
ITEM NO	SMR CODE	NSN	CAGEC	PART NUMBER	DESCRIPTION AND USABLE ON CODES(UOC)	QTY
GROUP 09 HEATER SUBASSEMBLY						
FIGURE 13						
1	PAOZZ	5305009931848	96906	MS35207-265	.SCREW,MACHINE.....	2
2	PAOZZ	5310000453296	96906	MS35338-43	.WASHER,LOCK.....	2
3	PAOZZ	5310000145850	96906	MS27183-42	.WASHER,FLAT.....	2
4	PAOOO		0V5R4	S9500-4258	.HEATER SUBASSEMBLY.....	1
5	XBOZZ	5340012664447	97403	13226E5917	..BRACKET,ANGLE.....	1
6	PAOZA	4520014762807	97403	13228E4258-5	..HEATING ELEMENT,ELE ELECTRICAL (INCLUDES ATTACHING HARDWARE).....	6
7	PAOZZ		0V5R4	13228E4258-5-1	...NUT,PLAIN,HEXAGON.....	1
8	XBOZZ		0V4R4	13228E4258-5-2	...WASHER,LOCK.....	1
9	XBOZZ		0V4R4	13228E4258-5-3	...WASHER,FLAT.....	1
10	XBOZZ		0V4R4	13228E4258-5-4	...WASHER,INSULATING.....	1
11	PAOZZ	5305009846194	80205	MS35206-246	..SCREW,MACHINE.....	6
12	PAOZZ	5310000453299	96906	MS35338-42	..WASHER,LOCK.....	6
13	XBOZZ		0V5R4	S9500-9939	..BRACKET,HEATER SUPPORT.....	1
14	PAOZZ	5310006162589	96906	MS27130-S93K	...NUT,PLAIN,BLIND RIV.....	2
15	PAOZZ		96906	MS35203-44	..SCREW,MACHINE.....	2
16	PBOZZ		83330	K21006-CB	..TERMINAL BOARD.....	1
17	XBOZZ		83330	K21006-101	..MARKER STRIP.....	1
18	PAOZZ	5325001745317	96906	MS35489-4	..GROMMET,NONMETALLIC.....	1
19	PAOZZ	5305009789350	96906	MS16997-22	..SCREW,CAP,SOCKET HE.....	4
20	PAOZZ	5310000454007	96906	MS35338-41	..WASHER,LOCK.....	4
21	PAOZZ		82647	S20490L22-12	..SWITCH.....	1
22	PAOZZ		81439	S9500-60TX11	..SWITCH.....	1
23	PAOZZ	5305009931851	96906	MS35207-267	..SCREW,MACHINE.....	3
24	PAOZZ	5310000453296	96906	MS35338-43	..WASHER,LOCK.....	3
25	PAOZZ		0V5R4	S9500-9940	..BRACKET,SWITCH.....	1
26	PAOZZ	5310011005202	96906	MS27130-S99K	...NUT,PLAIN,BLIND RIV.....	6
27	PAOZZ	5310010480553	96906	MS27130-S87K	...NUT,PLAIN,BLIND RIV.....	4

END OF FIGURE

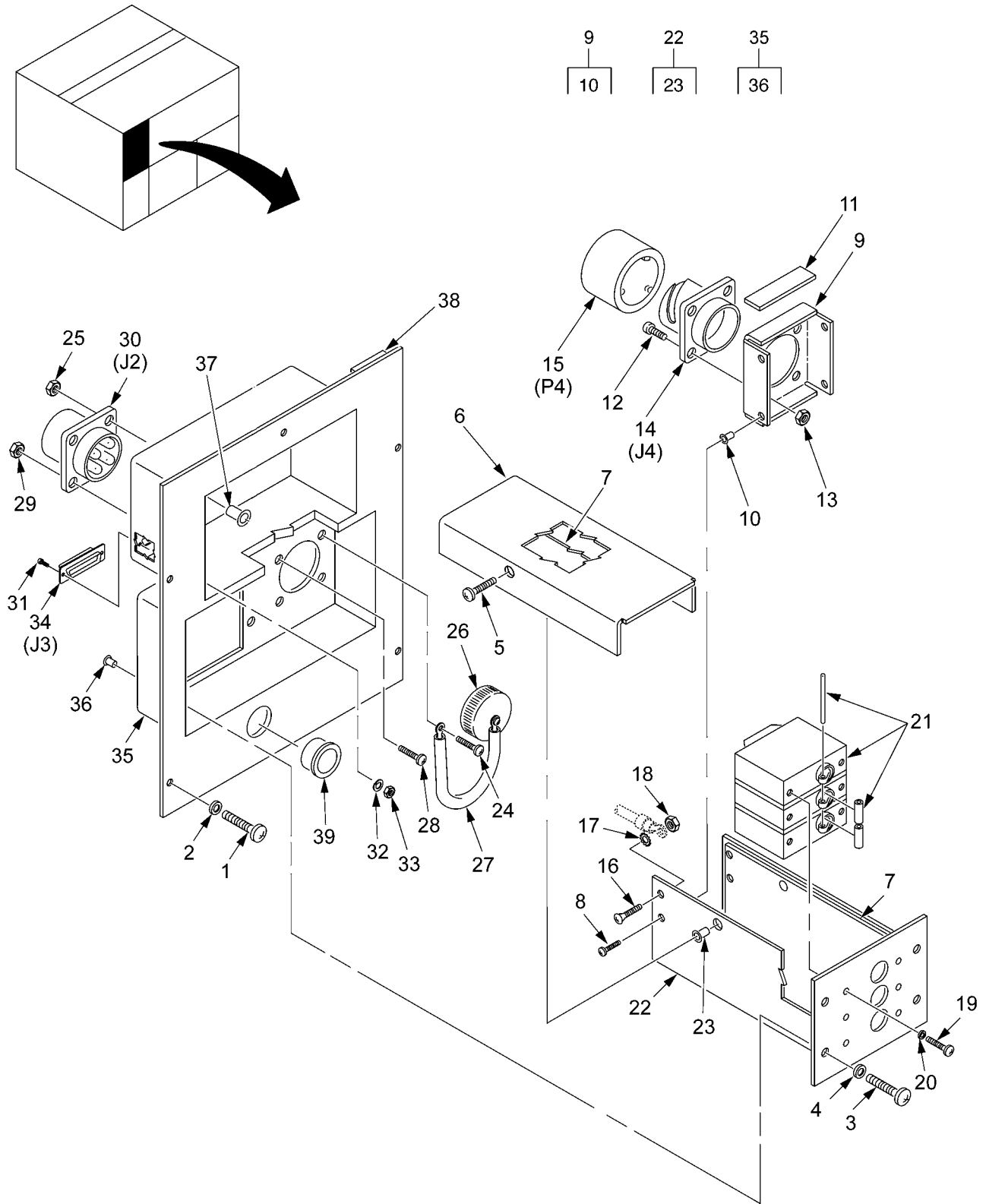

Figure 14. Circuit Breaker (Sheet 1 of 2)

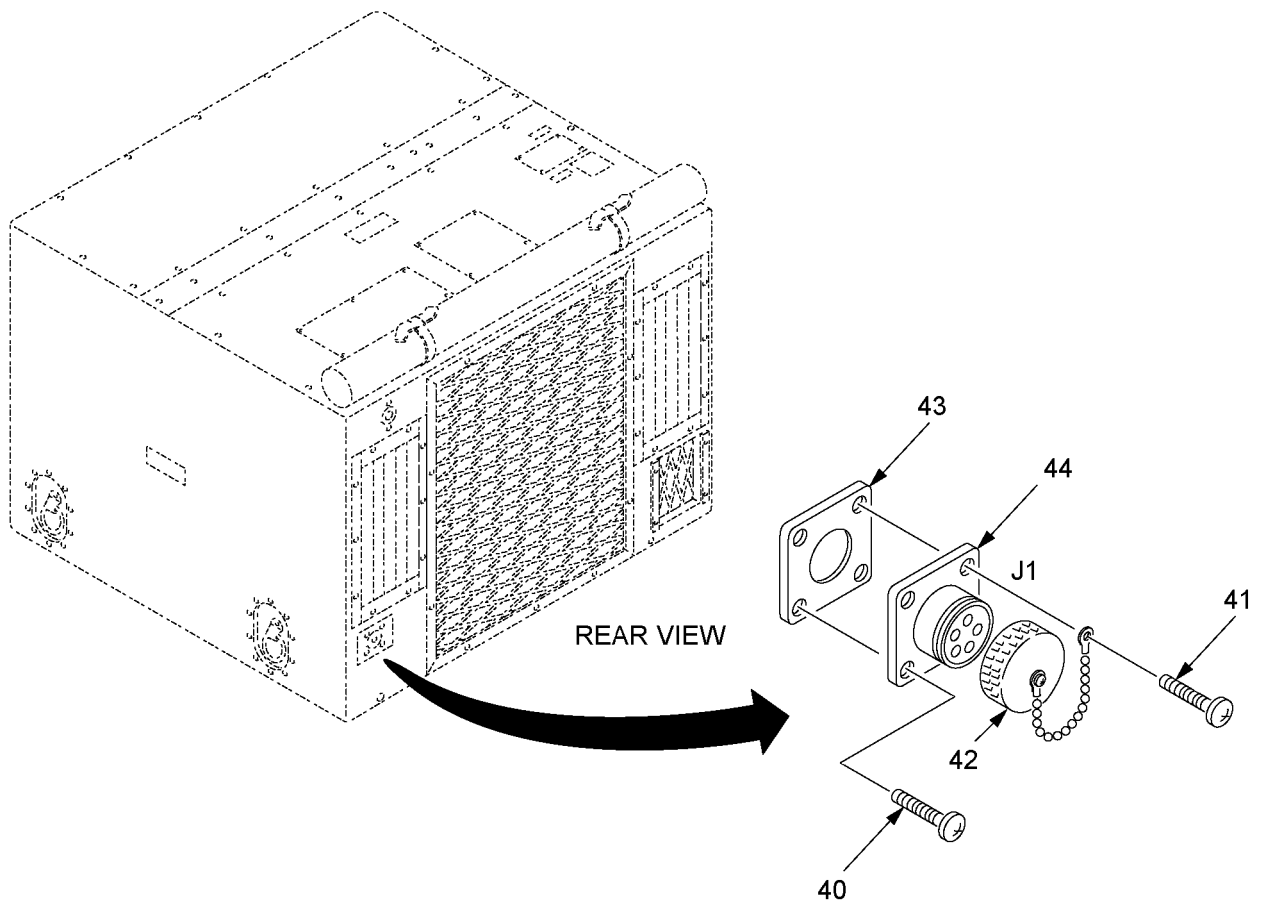

Figure 14. Circuit Breaker (Sheet 2 of 2)

SECTION II			TM9-4120-425-14&P			
(1)	(2)	(3)	(4)	(5)	(6)	(7)
ITEM	SMR		PART			
NO	CODE	NSN	CAGEC	NUMBER	DESCRIPTION AND USABLE ON CODES(UOC)	QTY
					GROUP 09	
					CIRCUIT BREAKER	
					ASSEMBLY	
FIGURE 14						
1	PAOZZ	5305009897435	96906	MS35207-264	.SCREW,MACHINE.....	5
2	PAOZZ	5310000453296	96906	MS35338-43	.WASHER,LOCK.....	5
3	PAOZZ	5305009540942	96906	MS35206-331	.SCREW,MACHINE.....	4
4	PAOZZ	5310000453299	96906	MS35338-42	.WASHER,LOCK.....	4
5	PAOZZ	5305009585473	96906	MS35190-251	.SCREW,MACHINE.....	2
6	PAOZZ		0V5R4	S9500-9921-2	.COVER.....	1
7	PAOZZ		30003	1559AS208	.INSULATION, ELECTRICAL.....	3
8	PAOZZ	5305009585473	96906	MS35190-251	.SCREW,MACHINE.....	2
9	XBOZZ		0V5R4	S9500-9921-3	.BRACKET,MOUNTING.....	1
10	PAOZZ	5310010480553	96906	MS27130-S87K	..NUT,PLAIN,BLIND RIV.....	4
11	MOOZZ		0V5R4	S9500-14-11	.INSULATION,THERMAL MAKE FROM	1
					INSULATION, P/N ASTM-C534TP2,.060THK	
12	PAOZZ	5305009846191	96906	MS35206-243	.SCREW,MACHINE.....	4
13	PAOZZ	5310008775795	96906	MS21044N8	.NUT,SELF-LOCKING,HE.....	4
14	PAOZZ		71389	CA3102E24-10PB	.CONNECTOR, RECEPTACLE, ELECTRICAL,	1
					J4.....	
15	PAOZZ		71389	CA3106E24-10SB	.CONNECTOR, RECEPTACLE, ELECTRICAL,	1
					P4.....	
16	PAOZZ	5305009585474	96906	MS35190-250	.SCREW,MACHINE.....	1
17	PAOZZ	5310005967693	96906	MS35335-31	.WASHER,LOCK.....	1
18	PAOZZ	5310008775795	96906	MS21044N8	.NUT,SELF-LOCKING,HE.....	1
19	PAOZZ	5305009844984	96906	MS35206-227	.SCREW,MACHINE.....	6
20	PAOZZ	5310007278353	96906	MS27183-43	.WASHER,FLAT.....	6
21	PAOZZ		82755	JA3S-K3-0040-02E	.CIRCUIT BREAKER.....	1
22	XBOZZ		0V5R4	S9500-9921	.HOUSING,CIRCUIT BREAKER.....	1
23	PAOZZ	5310009143290	96906	MS27130-S101K	..NUT,PLAIN,BLIND RIV.....	2
24	PAOZZ	5305008893001	96906	MS35206-231	.SCREW,MACHINE.....	1
25	PAOZZ	5310009500039	96906	MS21044-N6	.NUT,SELF-LOCKING,HE.....	1
26	PAOZZ	5935011761708	96906	MS25043-22DA	.COVER,ELECTRICAL CO CONNECTOR.....	1
27	MOOZZ	5970008142878	81349	M23053/5-106-9	.INSULATION SLEEVING MAKE FROM P/N	1
					M23053/5-106-9(81349) 4.5 INCHES	
					LONG.....	
28	PAOZZ	5305008893000	96906	MS35206-230	.SCREW,MACHINE.....	3
29	PAOZZ	5310008574957	80205	MS21044D6	.NUT,SELF-LOCKING,HE.....	3
30	PAOZZ		71389	75-190024-79P	.CONNECTOR, RECEPTACLE, ELECTRICAL,	1
					J2.....	
31	PAOZZ	5305009881167	96906	MS35206-204	.SCREW,MACHINE.....	2
32	PAOZZ	5310005435060	96906	MS35338-39	.WASHER,LOCK.....	2
33	PAOZZ	5310009349738	96906	MS35649-222	.NUT,PLAIN,HEXAGON.....	2
34	PAOZA	5935004903743	81349	M24308-4-2	.CONNECTOR,RECEPTACL J3.....	1
35	XBOZZ		0V5R4	S9500-9923	.PANEL.....	1
36	PAOZZ	5310006162589	96906	MS27130-S93K	..NUT,PLAIN,BLIND RIV.....	4
37	PAOZZ	5310009931548	96906	MS27130-S133K	..NUT,PLAIN,BLIND RIV.....	1
38	MOOZZ		0V5R4	S9500-14-37	.INSULATION SHEET MAKE FROM	1
					INSULATION, P/N ASTM-C534TP2,.25THK.	
39	PAOZZ	5975013627144	28520	2166	.BUSHING,ELECTRICAL.....	2
40	PAOZZ	5305008892999	96906	MS-35206-217	.SCREW,MACHINE.....	3
41	PAOZZ	5305009836730	96906	MS35206-218	.SCREW,MACHINE.....	1

SECTION II			TM9-4120-425-14&P			
(1)	(2)	(3)	(4)	(5)	(6)	(7)
ITEM	SMR			PART		
NO	CODE	NSN	CAGEC	NUMBER	DESCRIPTION AND USABLE ON CODES(UOC)	QTY
42	PAOZZ	5935011758417	96906	MS25043-24DA	.COVER,ELECTRICAL CO.....	1
43	PAOZZ	5330000637889	81343	MS51007-9	.GASKET.....	1
44	PAOZZ		71389	75-190024-79P	.CONNECTOR, RECEPTACLE, ELECTRICAL, J1.....	1

END OF FIGURE

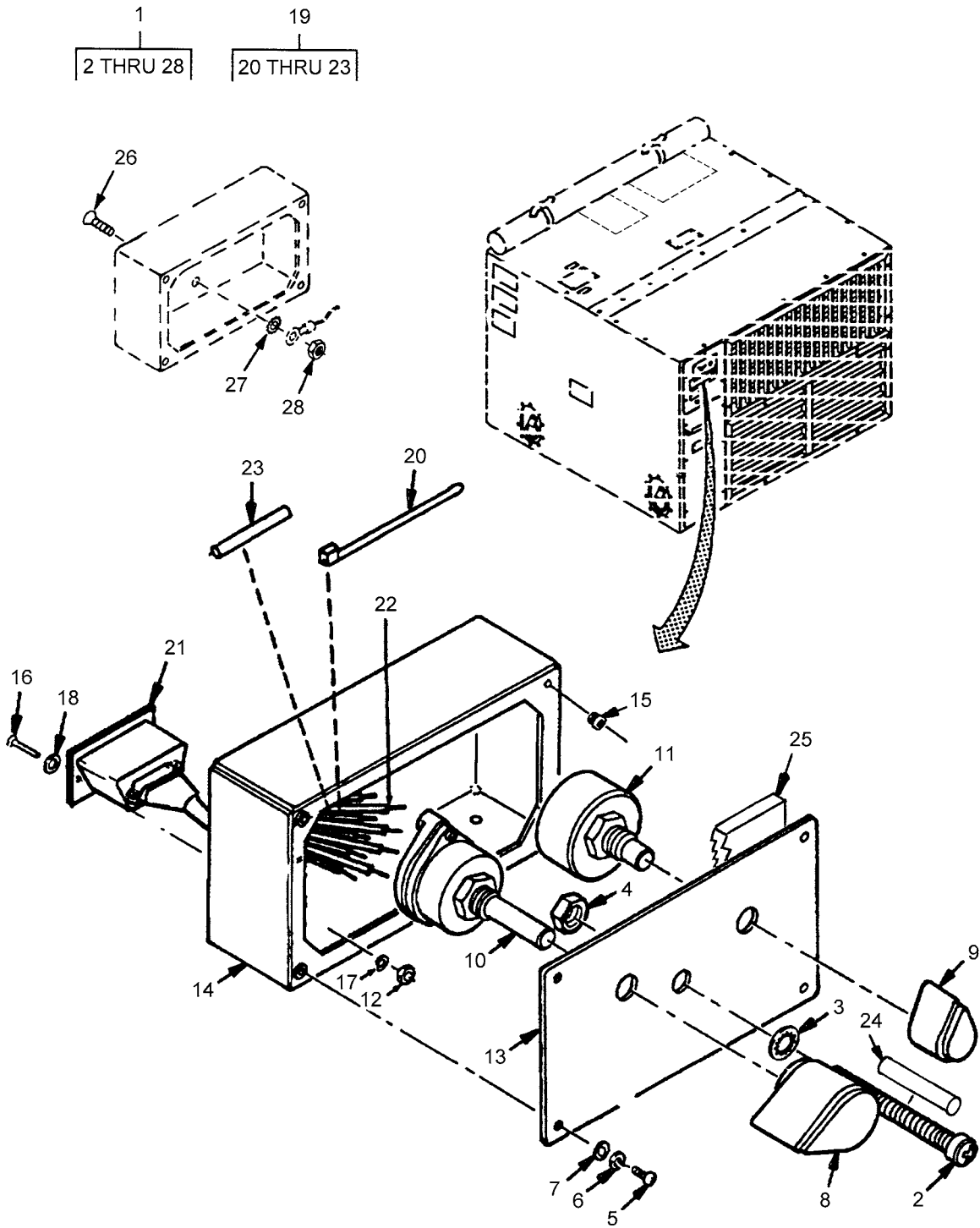

Figure 15. Remote Control Module

SECTION II			TM9-4120-425-14&P			
(1)	(2)	(3)	(4)	(5)	(6)	(7)
ITEM NO	SMR CODE	NSN	CAGEC	PART NUMBER	DESCRIPTION AND USABLE ON CODES(UOC)	QTY
GROUP 09 REMOTE CONTROL MODULE						

FIGURE 15

1	PAOOO		0V5R4	S9500-4190	.REMOTE CONTROL MODULE.....	1
2	PAOZZ	5305009586381	96906	MS35206-208	..SCREW,MACHINE.....	1
3	PAOZZ	5310008094058	96906	MS27183-10	..WASHER,FLAT.....	1
4	PAOZZ	5310000881251	81349	M45913/1-4CG5C	..NUT,SELF-LOCKING,HE.....	1
5	PAOZZ	5305008892997	96906	MS35206-215	..SCREW,MACHINE.....	4
6	PAOZZ	5310005432410	96906	MS35338-40	..WASHER,LOCK.....	4
7	PAOZZ	5310009501310	96906	MS27183-4	..WASHER,FLAT.....	4
8	PAOZZ	5355005560145	96906	MS91528-1K2B	..KNOB CONTROL, PLASTIC, 1/4 IN. ROUND SHAFT.....	1
9	PAOZZ	5355005560145	96906	MS91528-1K2B	..KNOB CONTROL, PLASTIC, 1/4 IN. ROUND SHAFT.....	1
10	PAOZZ	5930014666331	0V5R4	C4D0304N-9833	..SWITCH,ROTARY 1.00 IN. DIA, 12 POSITION.....	1
11	PAOZZ		52516	AH4101	..RESISTOR,VARIABLE, 100 OHM.....	1
12	PAOZZ	5310009349738	96906	MS35649-222	..NUT,PLAIN,HEXAGON.....	2
13	XAOZZ		0V5R4	S9500-4192	..PANEL,CONTROL.....	1
14	XBOZZ		0V5R4	S9500-4191	..BOX,CONTROL.....	1
15	PAOZZ	5310010117989	81349	M45938/1-5	...NUT,PLAIN,CLINCH 112-40 UNC-2B..	4
16	PAOZZ	5305009881167	96906	MS35206-204	..SCREW,MACHINE.....	2
17	PAOZZ	5310000870057	96906	MS27183-2	..WASHER,FLAT.....	2
18	PAOZZ	5310005435060	96906	MS35338-39	..WASHER,LOCK.....	2
19	PAOOO		0V5R4	S9500-4274	..WIRING HARNESS.....	1
20	PAOZZ	5975001113208	96906	MS3367-5-9	...STRAP,TIEDOWN,ELECT.....	5
21	PAOZZ	5935014708413	81349	M24308/4-303	...CONNECTOR,RECEPTACL.....	1
22	MOOZZ		0V5R4	S9500-4274/2	...WIRE,ELECTRICAL MAKE FROM WIRE P/N M5086/1-20-9, CUT TO LENGTH.....	8
23	MOOZZ		0V5R4	S9500-4190/16	...INSULATION SLEEVING MAKE FROM INSULATION SLEEVING, P/N M23053/5- 104-9.....	8
24	MOOZZ	5970008142878	81349	M23053/5-106-9	..INSULATION SLEEVING MAKE FROM P/ N M23053/5-106-9 (81349), 2 INCHES	1
25	MOOZZ		0V5R4	S9500-15-25	..INSULATION,THERMAL MAKE FROM INSULATION, P/N ASTM-C534TP2,.125THK	1
26	PAOZZ	5305009585474	96906	MS35190-250	..SCREW,MACHINE.....	1
27	PAOZZ	5310008206653	96906	MS35338-50	..WASHER,LOCK.....	1
28	PAOZZ	5310008775795	96906	MS21044N8	..NUT,SELF-LOCKING,HE.....	1

END OF FIGURE

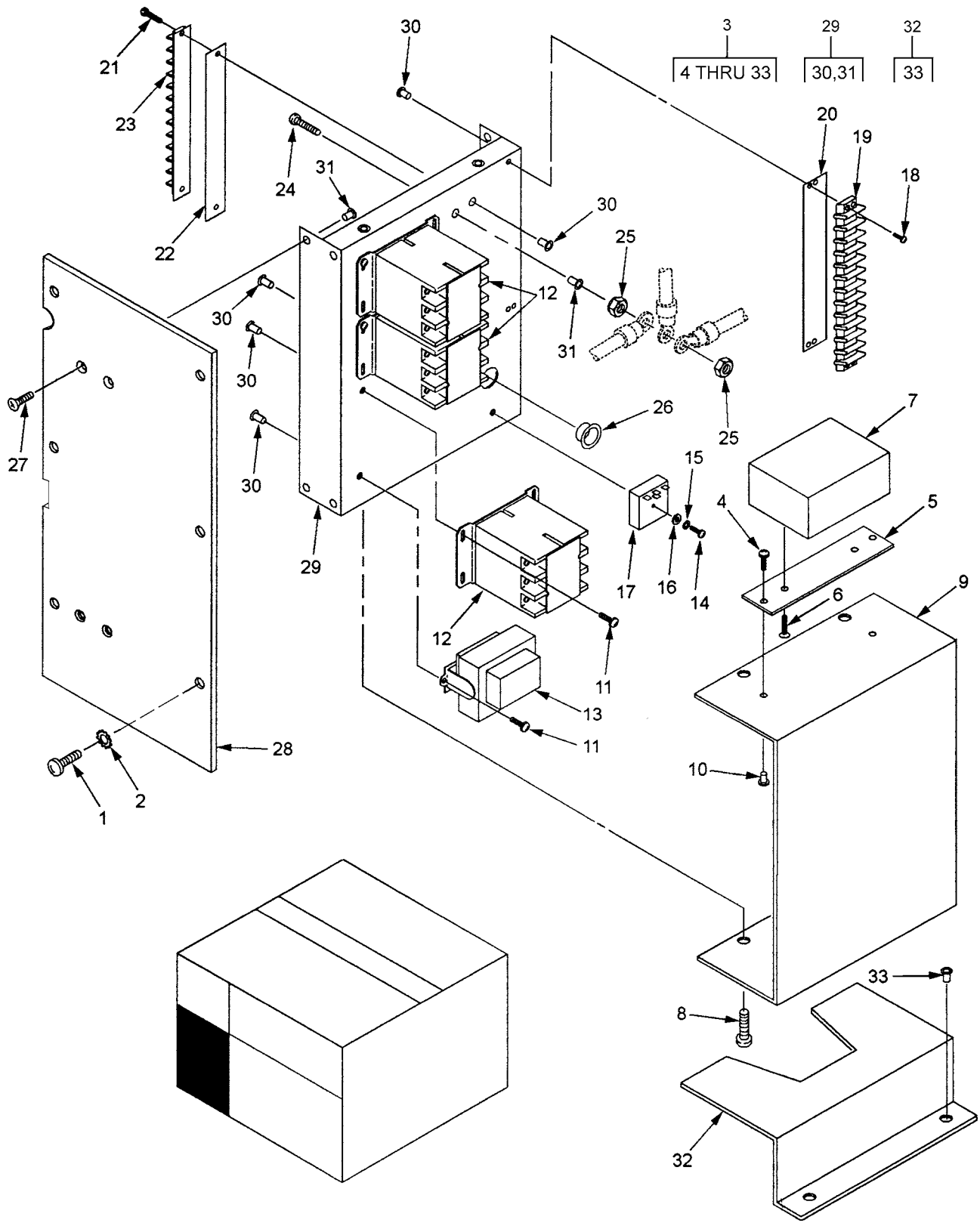

Figure 16. Junction Box (Sheet 1 of 2)

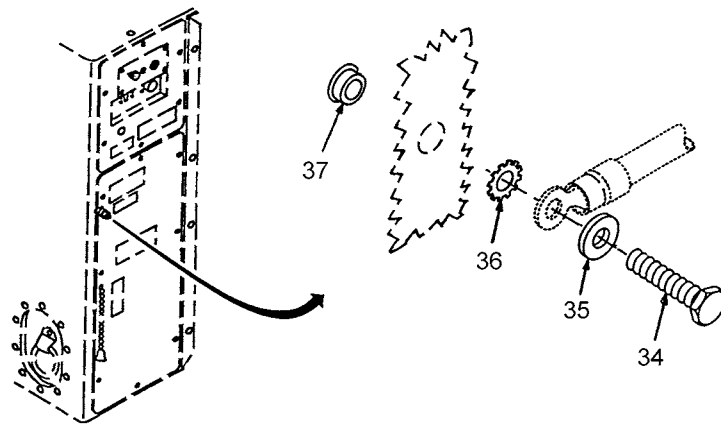

Figure 16. Junction Box (Sheet 2 of 2)

SECTION II			TM9-4120-425-14&P			
(1)	(2)	(3)	(4)	(5)	(6)	(7)
ITEM NO	SMR CODE	NSN	CAGEC	PART NUMBER	DESCRIPTION AND USABLE ON CODES(UOC)	QTY
GROUP 10 JUNCTION BOX ASSEMBLY						
FIGURE 16						
1	PAOZZ	5305009897435	96906	MS35207-264	.SCREW,MACHINE.....	8
2	PAOZZ	5310000453296	96906	MS35338-43	.WASHER,LOCK.....	8
3	XBOOO		0V5R4	S9500-JBA-01	.JUNCTION BOX ASSY.....	1
4	PAOZZ	5305009897435	96906	MS35207-264	..SCREW,MACHINE.....	2
5	XBOZZ		0V5R4	S9500-9938	..STRAP.....	1
6	PAOZZ	5305009846191	96906	MS35206-243	..SCREW,MACHINE.....	2
7	PAOZZ		0V5R4	S9500-6670	..THERMOSTAT, ELECTRONIC.....	1
8	PAOZZ	5305009897435	96906	MS35207-264	..SCREW,MACHINE.....	4
9	XBOZZ		0V5R4	S9500-9932	..COVER W/CLIP.....	1
10	PAOZZ	5310006162589	96906	MS27130-S93K	...NUT,PLAIN,BLIND RIV.....	3
11	PAOZZ	5305009846194	80205	MS35206-246	..SCREW,MACHINE.....	8
12	PAOZZ		0NY81	S3100-30Q9999CY	..RELAY.....	3
13	PAOZZ		0NY81	S4100-949	..TRANSFORMER.....	1
14	PAOZZ		96906	MS24693-256	..SCREW,MACHINE.....	1
15	PAOZZ	5310000453299	96906	MS35338-42	..WASHER,LOCK.....	1
16	PAOZZ	5310008098544	96906	MS27183-7	..WASHER,FLAT.....	1
17	PAOZZ		52516	HMPS24A9X60	..RELAY,THERMAL.....	1
18	PAOZZ	5305009846194	80205	MS35206-246	..SCREW,MACHINE.....	2
19	PAOZZ		75382	602GP-12	..TERMINAL BOARD.....	1
20	PAOZZ		75382	602GP-12MS	..MARKER STRIP.....	1
21	PAOZZ	5305009577820	96906	MS24693-S31	..SCREW,MACHINE.....	2
22	PAOZZ	9905013480495	97403	13216E6221-1	..PLATE,IDENTIFICATIO.....	1
23	PAOZZ	5940012017221	97403	13216E6220-1	..TERMINAL BOARD.....	1
24	PAOZZ	5305009897435	96906	MS35207-264	..SCREW,MACHINE.....	1
25	PAOZZ	5310008775797	96906	MS21044N3	..NUT,SELF-LOCKING,HE.....	2
26	PAOZZ	5325001850012	96906	MS35489-35	..GROMMET,NONMETALLIC.....	1
27	PAOZZ	5305009897435	96906	MS35207-264	..SCREW,MACHINE.....	4
28	XBOZZ		0V5R4	S9500-9954	..PLATE.....	1
29	XBOZZ		0V5R4	S9500-9927	..CHASSIS.....	1
30	PAOZZ	5310006162589	96906	MS27130-S93K	...NUT,PLAIN,BLIND RIV.....	19
31	PAOZZ	5310011005202	96906	MS27130-S99K	...NUT,PLAIN,BLIND RIV.....	4
32	XBOZZ		0V5R4	S9500-9959	..BRACKET.....	1
33	PAOZZ	5310006162589	96906	MS27130-S93K	...NUT,PLAIN,BLIND RIV.....	2
34	PAOZZ	5305000680516	80204	B1821BH025F113N	.SCREW,CAP,HEXAGON H.....	1
35	PAOZZ	5310008094058	96906	MS27183-10	.WASHER,FLAT.....	1
36	PAOZZ	5310002090786	96906	MS35335-33	.WASHER,LOCK.....	1
37	PAOZZ		96906	MS27130-S50K	.NUT,BLIND RIVET.....	1

END OF FIGURE

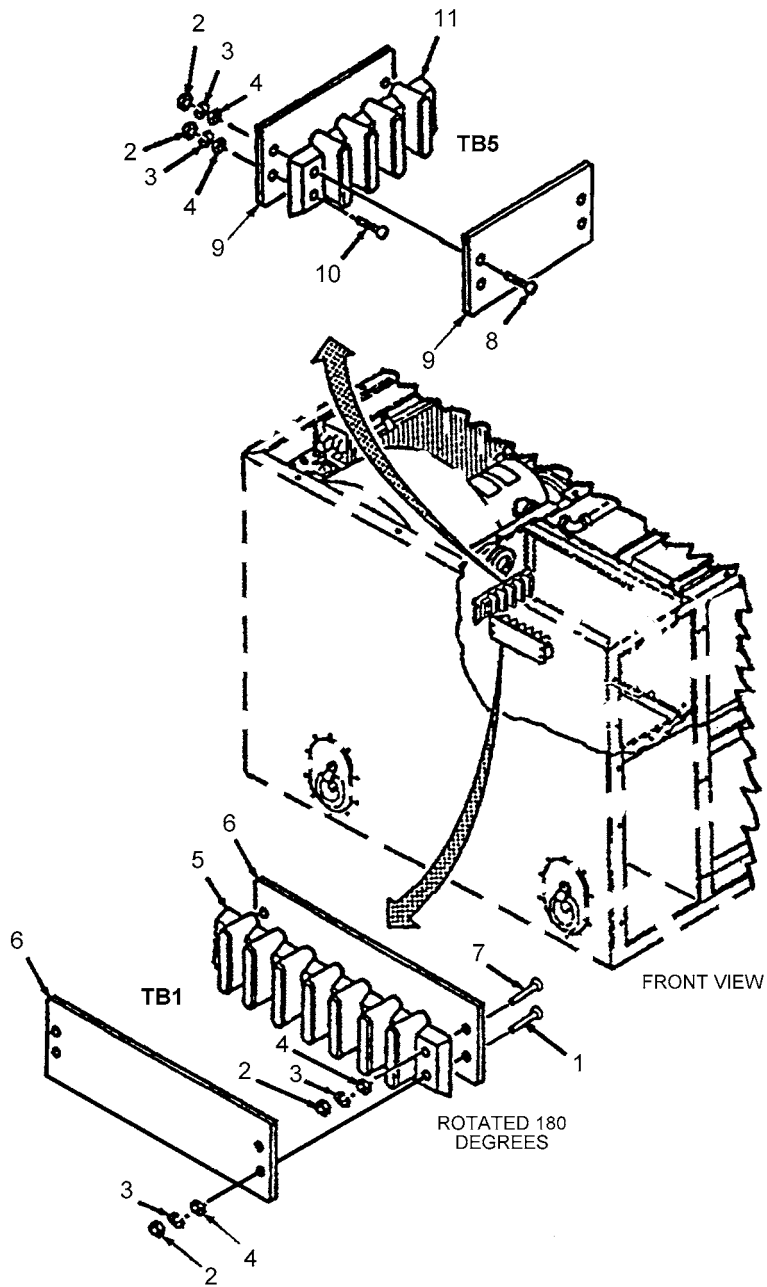

Figure 17. Terminal Boards (TB1 and TB5)

SECTION II			TM9-4120-425-14&P			
(1)	(2)	(3)	(4)	(5)	(6)	(7)
ITEM	SMR			PART		
NO	CODE	NSN	CAGEC	NUMBER	DESCRIPTION AND USABLE ON CODES(UOC) QTY	

GROUP 10 TERMINAL BOARDS

FIGURE 17

1	PAOZZ	5305000512355	96906	MS24693-S60	.SCREW,MACHINE.....	2
2	PAOZZ	5310009349757	96906	MS35649-282	.NUT,PLAIN,HEXAGON.....	8
3	PAOZZ	5310000453299	96906	MS35338-42	.WASHER,LOCK.....	8
4	PAOZZ	5310007653197	96906	MS27183-41	.WASHER,FLAT.....	8
5	PAOZZ		83330	606GP-6	.TERMINAL BOARD.....	1
6	XBOZZ		83330	606GP-MS6	.MARKER STRIP.....	2
7	PAOZZ	5305009577821	96906	MS24693-S54	.SCREW,MACHINE.....	2
8	PAOZZ	5305000512355	96906	MS24693-S60	.SCREW,MACHINE.....	2
9	XBOZZ		83330	603GP-MS	.MARKER,IDENTIFICAT.....	2
10	PAOZZ	5305009577821	96906	MS24693-S54	.SCREW,MACHINE.....	2
11	PAOZZ		83330	603GP-8	.TERMINAL BOARD.....	1

END OF FIGURE

36 K HORIZONTAL A/C INPUT POWER

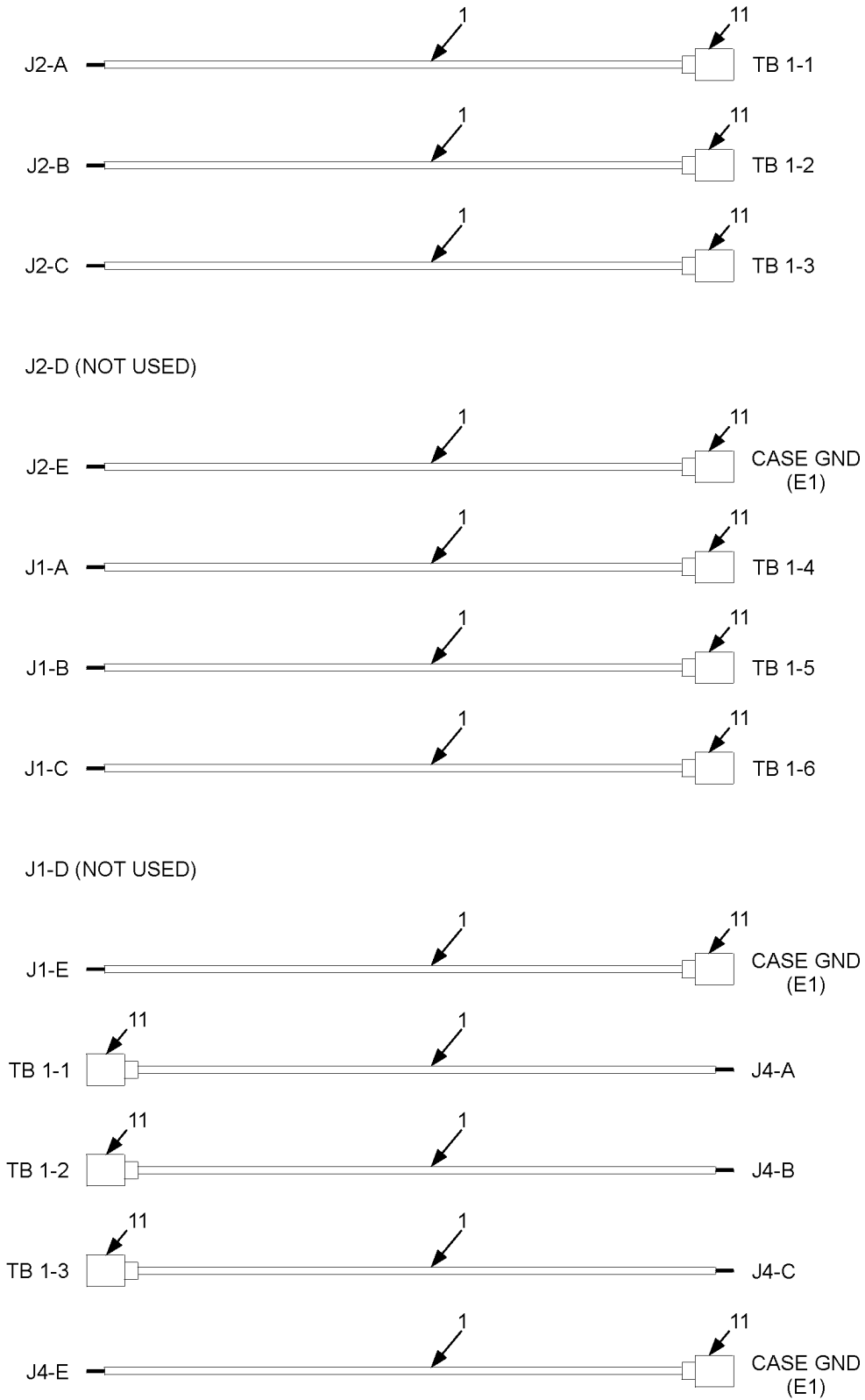

Figure 18. Unit Wiring (Sheet 1 of 10)

36 K HORIZONTAL A/C INPUT POWER (Continued)

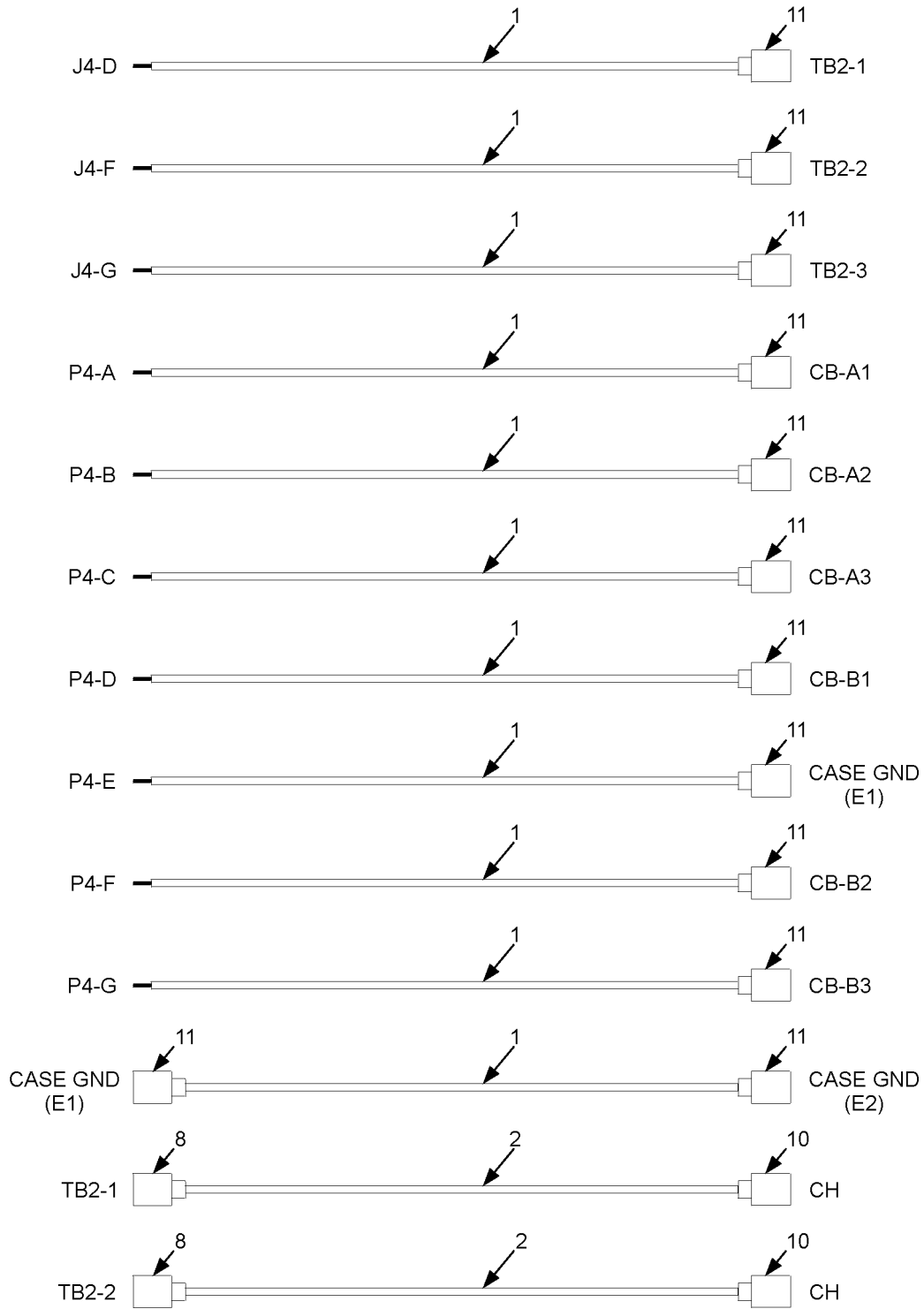

Figure 18. Unit Wiring (Sheet 2 of 10)

ELECTRICAL CONTROL JUNCTION BOX - POWER

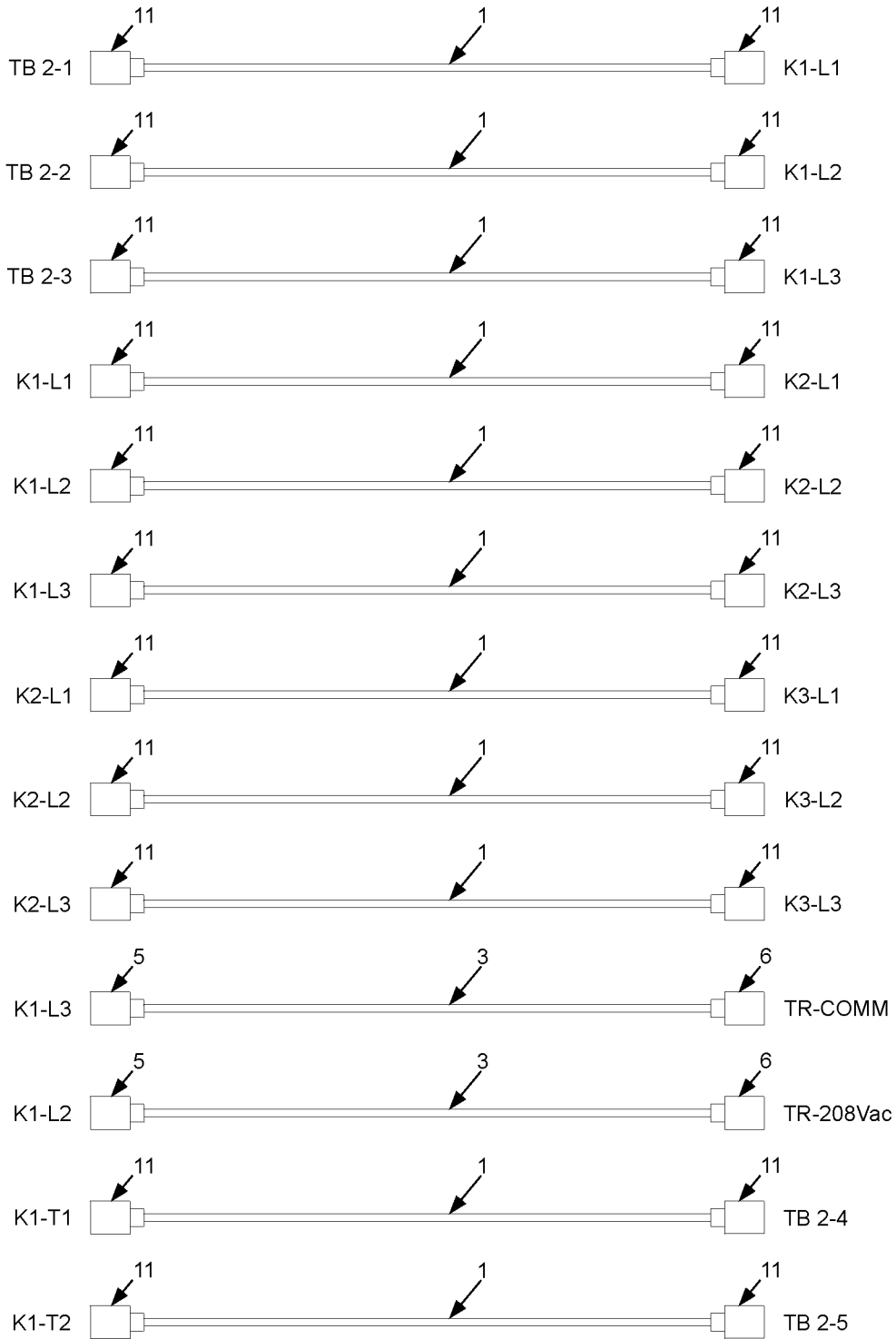
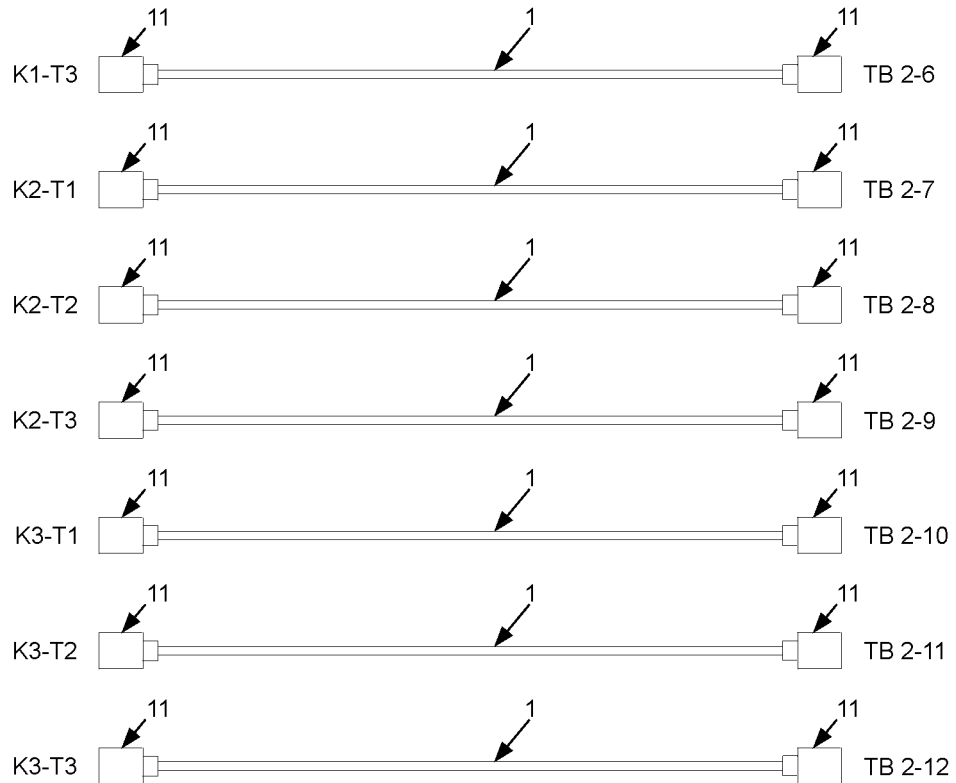

Figure 18. Unit Wiring (Sheet 3 of 10)

ELECTRICAL CONTROL JUNCTION BOX - POWER (Continued)



ELECTRICAL CONTROL JUNCTION BOX - CONTROL

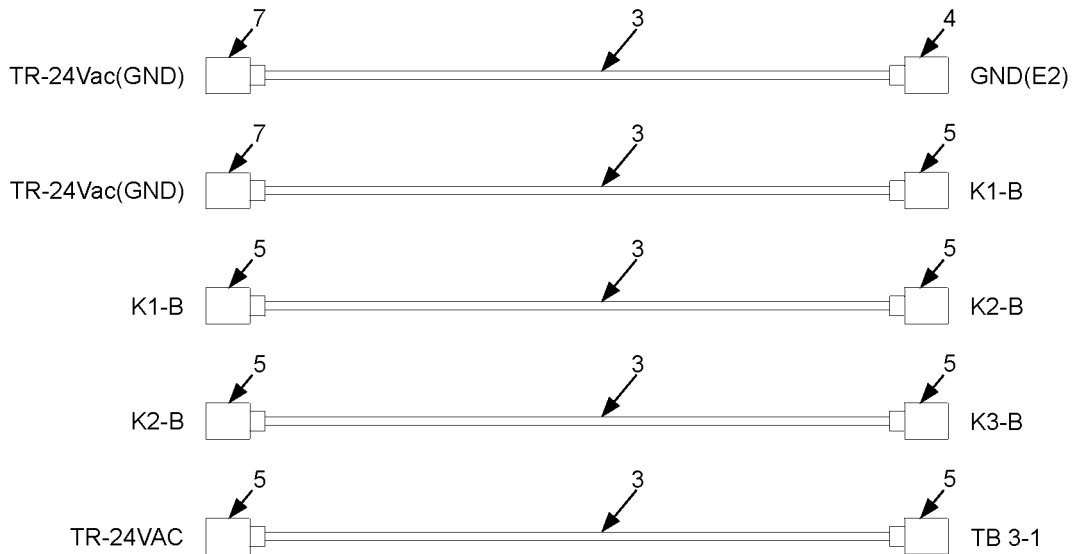

Figure 18. Unit Wiring (Sheet 4 of 10)

ELECTRICAL CONTROL JUNCTION BOX - CONTROL (Continued)

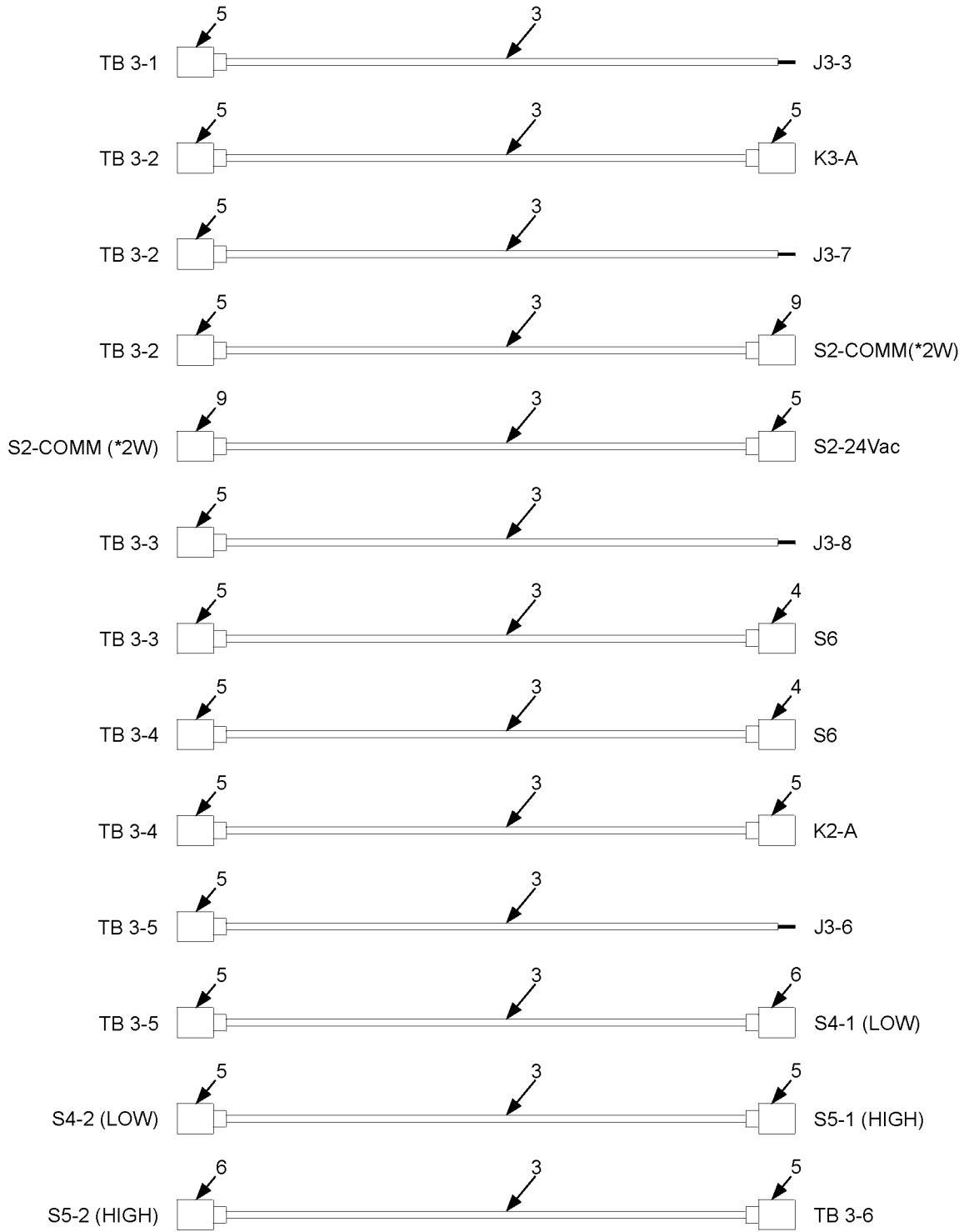

Figure 18. Unit Wiring (Sheet 5 of 10)

ELECTRICAL CONTROL JUNCTION BOX - CONTROL (Continued)

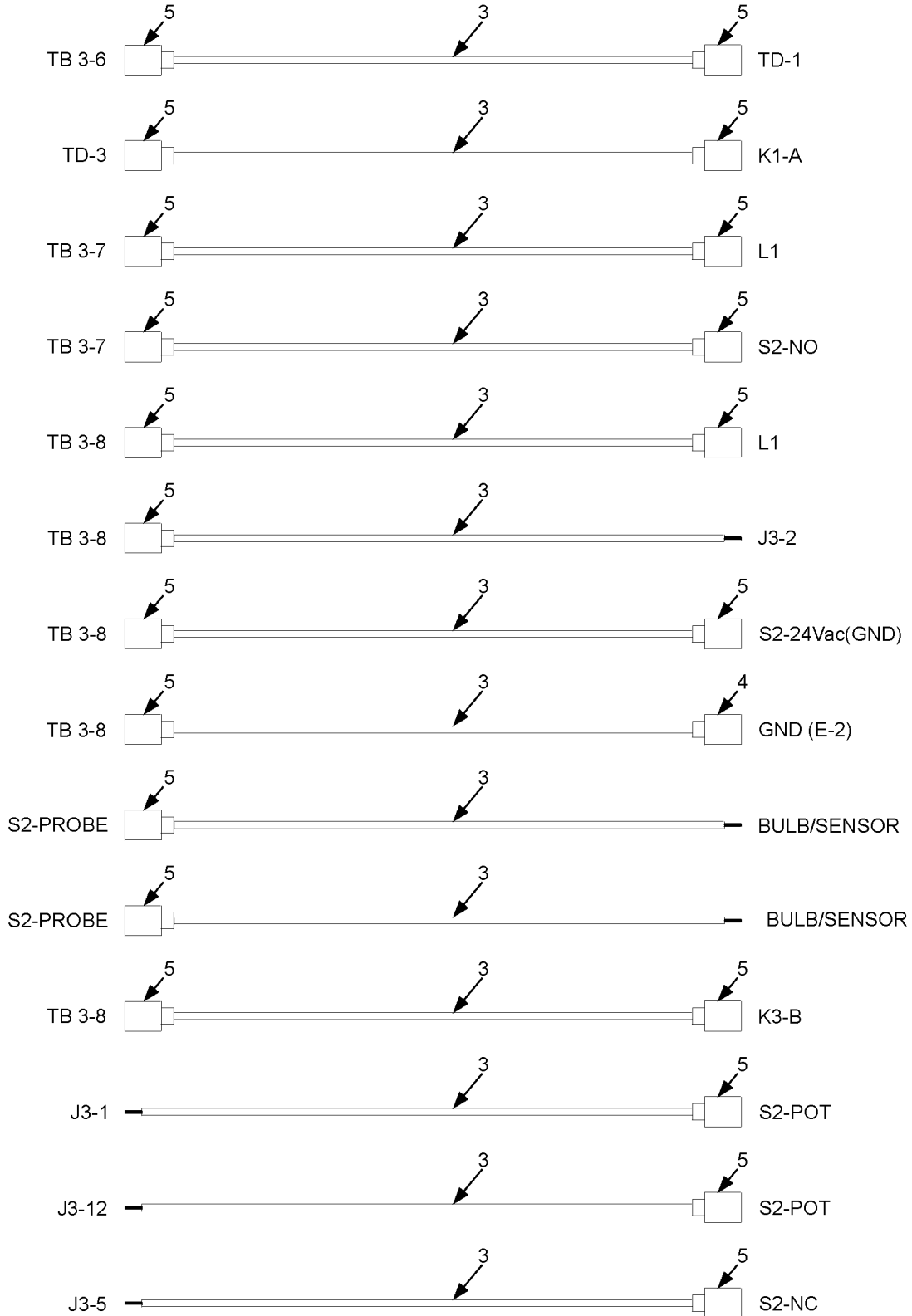
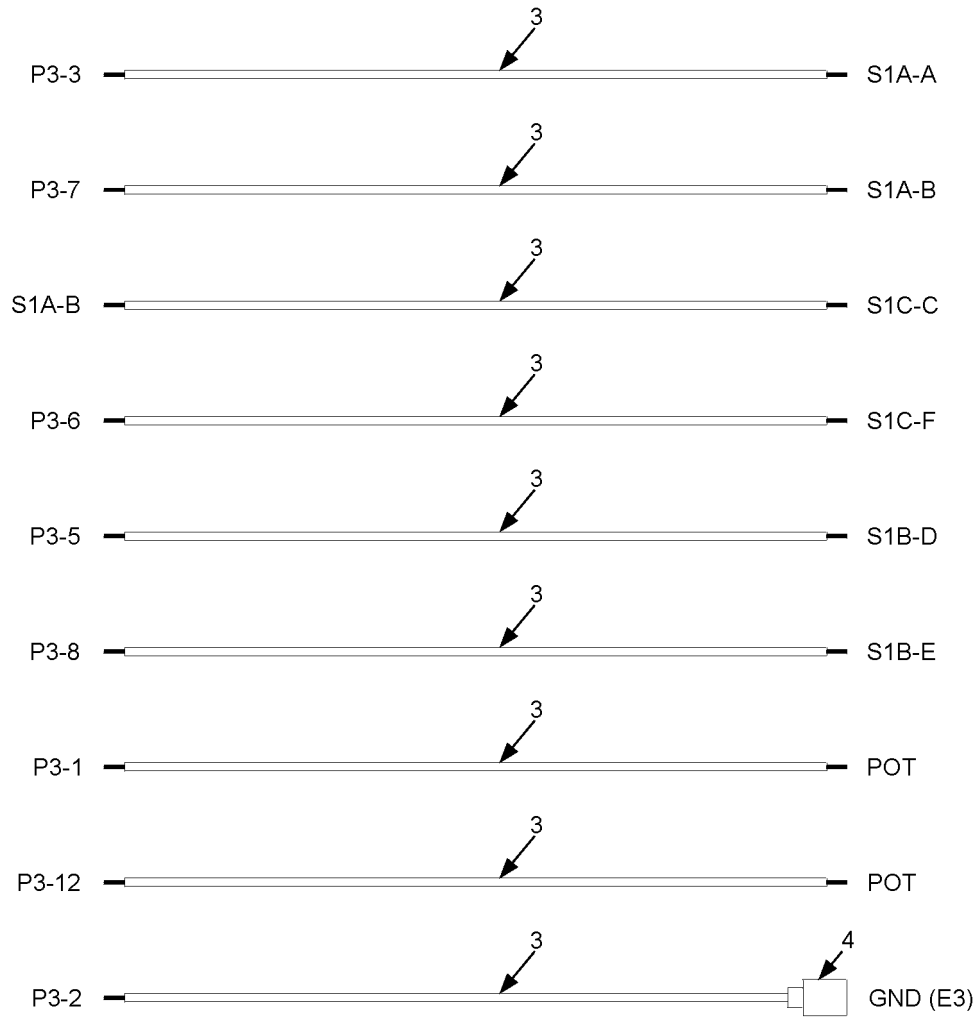

Figure 18. Unit Wiring (Sheet 6 of 10)

REMOTE CONTROL BOX - CONTROL



ELECTRICAL CONTROL JUNCTION BOX - POWER

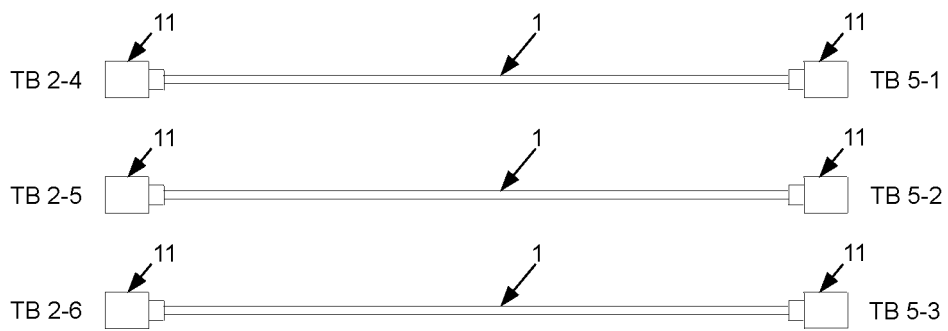

Figure 18. Unit Wiring (Sheet 7 of 10)

ELECTRICAL CONTROL JUNCTION BOX - POWER (Continued)

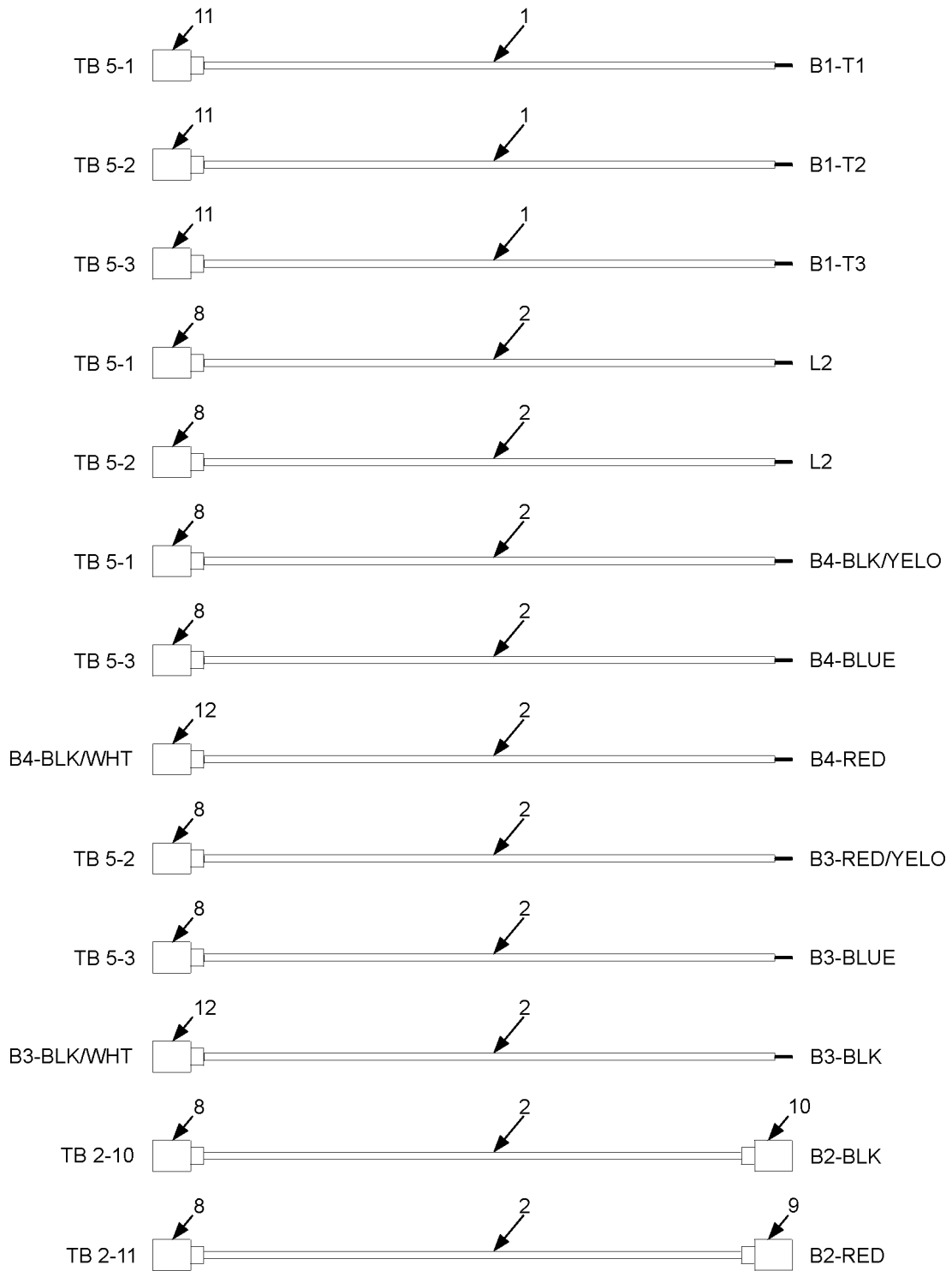
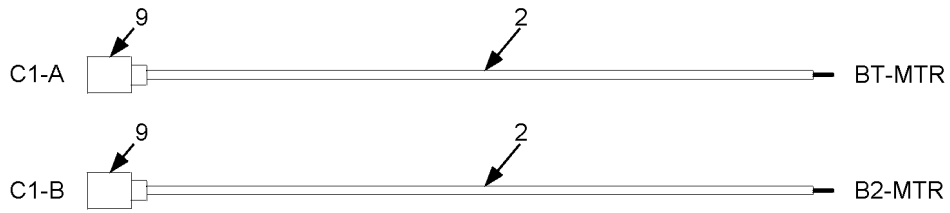
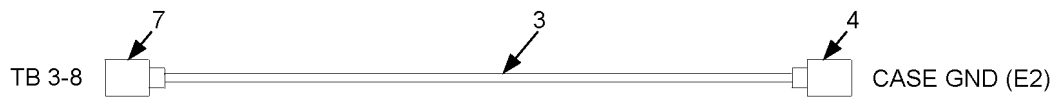

Figure 18. Unit Wiring (Sheet 8 of 10)

ELECTRICAL CONTROL JUNCTION BOX - POWER (Continued)



TB 2-12 (NOT USED)



ELECTRICAL HEATERS - POWER

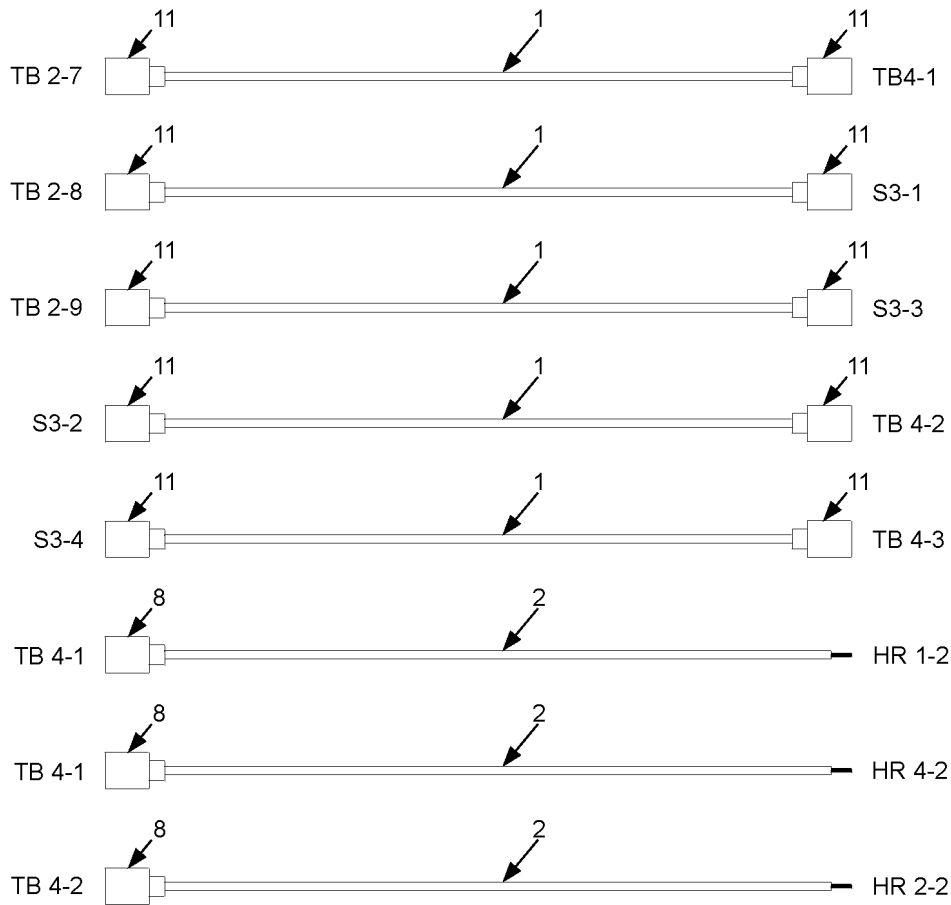

Figure 18. Unit Wiring (Sheet 9 of 10)

ELECTRICAL HEATERS - POWER (Continued)

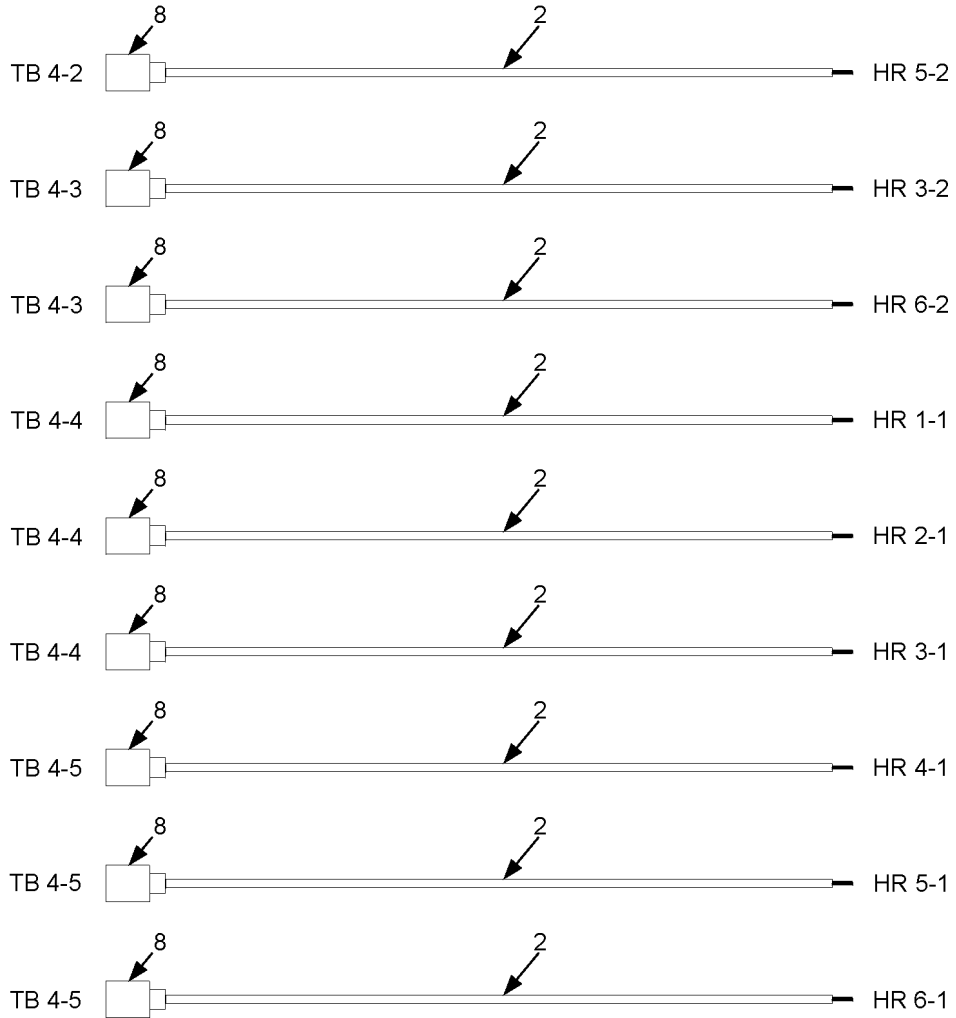

Figure 18. Unit Wiring (Sheet 10 of 10)

SECTION II			TM9-4120-425-14&P			
(1)	(2)	(3)	(4)	(5)	(6)	(7)
ITEM NO	SMR CODE	NSN	CAGEC	PART NUMBER	DESCRIPTION AND USABLE ON CODES(UOC)	QTY
GROUP 11 UNIT WIRING						
FIGURE 18						
1	MOOZZ	6145005787513	81349	M5086/2-10-9	.WIRE,ELECTRICAL MAKE FROM P/N M5086/2-10-9 (81349).....	52
2	MOOZZ	6145005786604	81349	M5086/2-14-9	.WIRE,ELECTRICAL MAKE FROM P/N M5086/2-14-9 (81349).....	26
3	MOOZZ	6145008518505	81349	M5086/2-20-9	.WIRE,ELECTRICAL MAKE FROM P/N M5086/2-20-9 (81349).....	43
4	PAOZZ	5940001434771	06383	PN18-10R	.TERMINAL,LUG.....	5
5	PAOZZ		06383	DNF18-250FIB	.TERMINAL,LUG WIRE NO.22-18,RED INSULATOR.....	46
6	PAOZZ		06383	DNFR18-250FIB	.TERMINAL,LUG.....	4
7	PAOZZ		06383	DV18-250MB	.TERMINAL,LUG.....	3
8	PAOZZ		06383	PN14-10R	.TERMINAL,LUG.....	22
9	PAOZZ	5940011390853	06383	DNF14-250FIM	.TERMINAL,QUICK DISC.....	4
10	PAOZZ		06383	BSV14X	.SPLICE,CONDUCTOR.....	3
11	PAOZZ	5940001434794	06383	PN10-10R	.TERMINAL,LUG.....	79
12	PAOZZ	5940013504066	06383	JN418-212	.SPLICE,CONDUCTOR.....	1

END OF FIGURE

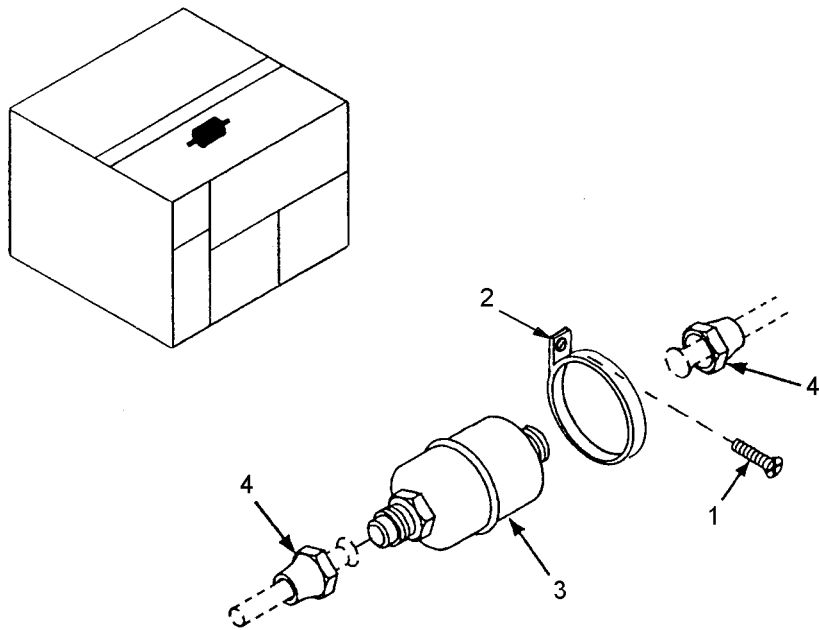

Figure 19. Dehydrator (Filter-Drier)

SECTION II			TM9-4120-425-14&P			
(1)	(2)	(3)	(4)	(5)	(6)	(7)
ITEM NO	SMR CODE	NSN	CAGEC	PART NUMBER	DESCRIPTION AND USABLE ON CODES(UOC)	QTY
					GROUP 12 DEHYDRATOR (FILTER-DRIER)	

FIGURE 19

1	PAFZZ	5305000633503	96906	MS24693-S50	.SCREW,MACHINE CAD PLTD,NO.8,0.50 IN.....	1
2	XBFZZ		96906	MS21919WDG48	.CLAMP,LOOP.....	1
3	PAFZZ		70255	053	.FILTER-DRIER,REFRIG.....	1
4	PBFZZ	4730001892739	96906	MS35872-3	.NUT,TUBE COUPLING.....	2

END OF FIGURE

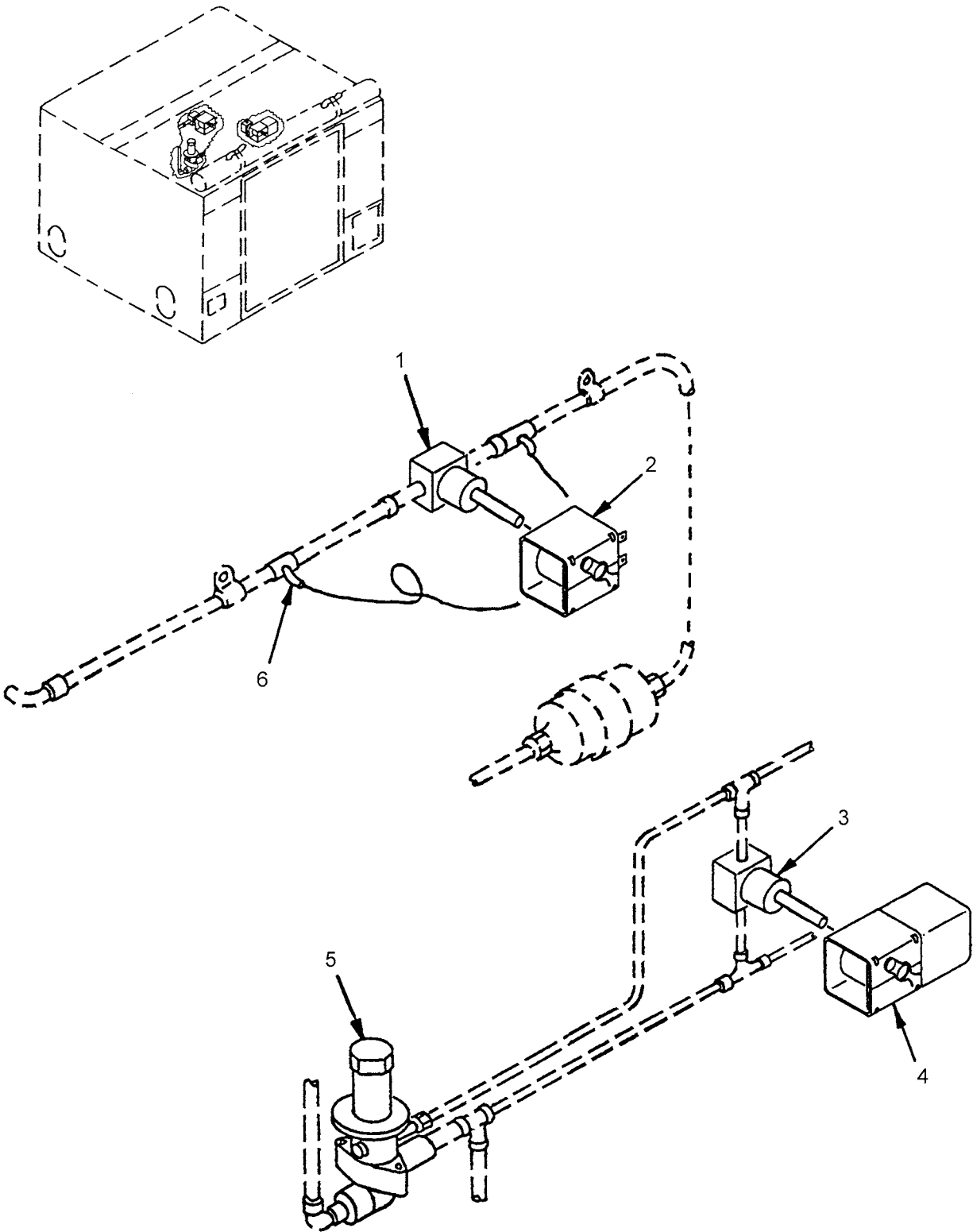

Figure 20. Solenoid Valves

SECTION II			TM9-4120-425-14&P			
(1)	(2)	(3)	(4)	(5)	(6)	(7)
ITEM NO	SMR CODE	NSN	CAGEC	PART NUMBER	DESCRIPTION AND USABLE ON CODES(UOC)	QTY

GROUP 12 SOLENOID VALVES

FIGURE 20

1	PAFZZ	4810013277651	70255	200RB-3T3	.VALVE,SOLENOID LIQUID LINE (VALVE ONLY).....	1
2	PAOZZ		70255	AMS24-50/60	.COIL,SOLENOID VALVE.....	1
3	PAFZZ		70255	500RB272VLC	.VALVE,SOLENOID, EQUALIZATION (VALVE ONLY).....	1
4	PAOZZ		70255	AMG208/220	.COIL,SOLENOID VALVE.....	1
5	PAFZF	4820001650963	70255	CPHE4	.VALVE,REGULATING,FL BY-PASS.....	1
6	PAFZZ		0V5R4	S9500-THEQ	.SUPERHEATER.....	1

END OF FIGURE

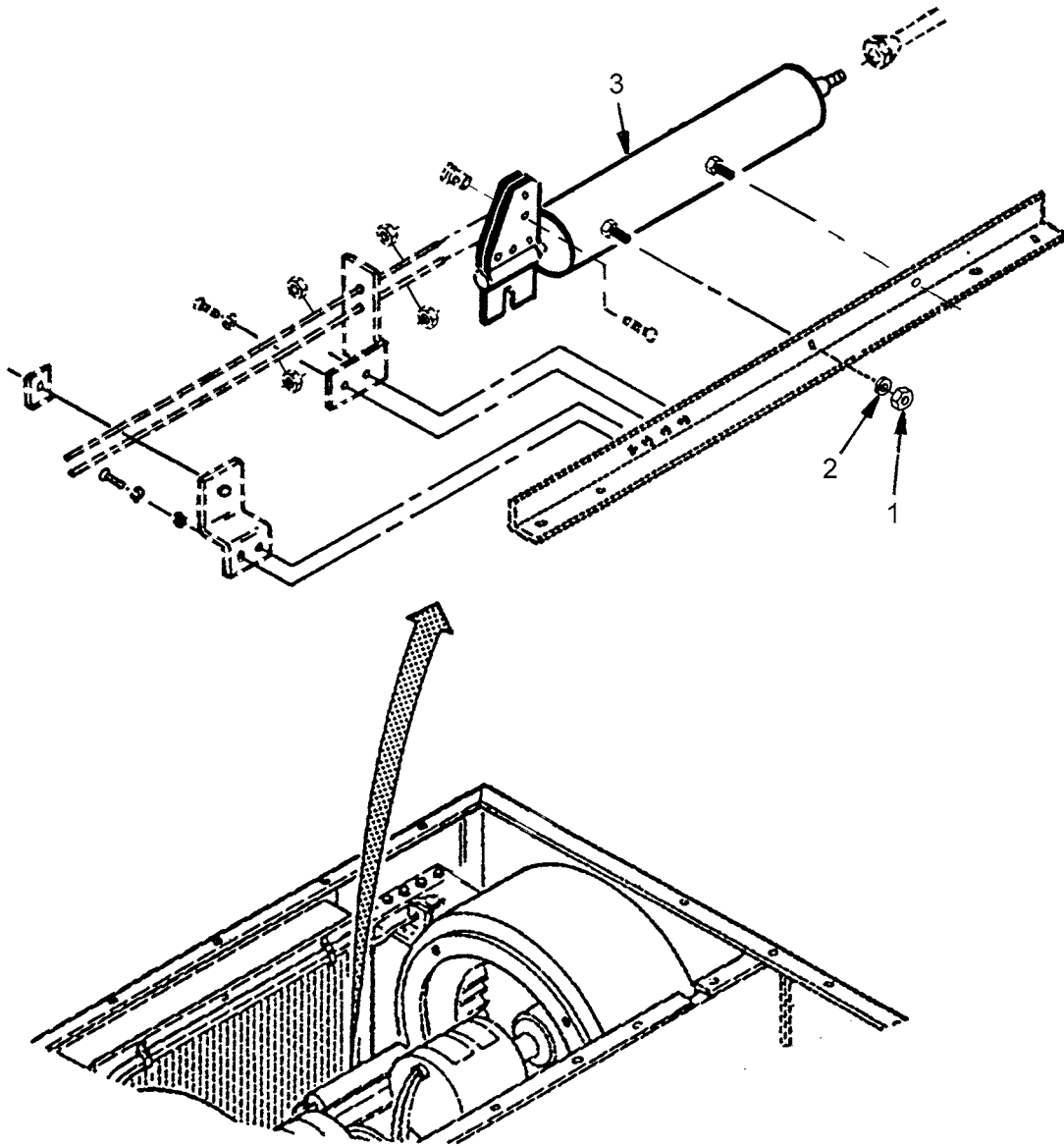

Figure 21. Damper Actuator Cylinder

SECTION II			TM9-4120-425-14&P			
(1)	(2)	(3)	(4)	(5)	(6)	(7)
ITEM	SMR			PART		
NO	CODE	NSN	CAGEC	NUMBER	DESCRIPTION AND USABLE ON CODES(UOC)	QTY

GROUP 12 DAMPER ACTUATOR
CYLINDER

FIGURE 21

1	PAFZZ	5310009971888	96906	MS35649-2252	.NUT,PLAIN,HEXAGON.....	2
2	PAFZZ	5310005825965	96906	MS35338-44	.WASHER,LOCK.....	2
3	PAFZZ	4130004792744	97403	13216E6330	.CYLINDER,ACTUATING,.....	1

END OF FIGURE

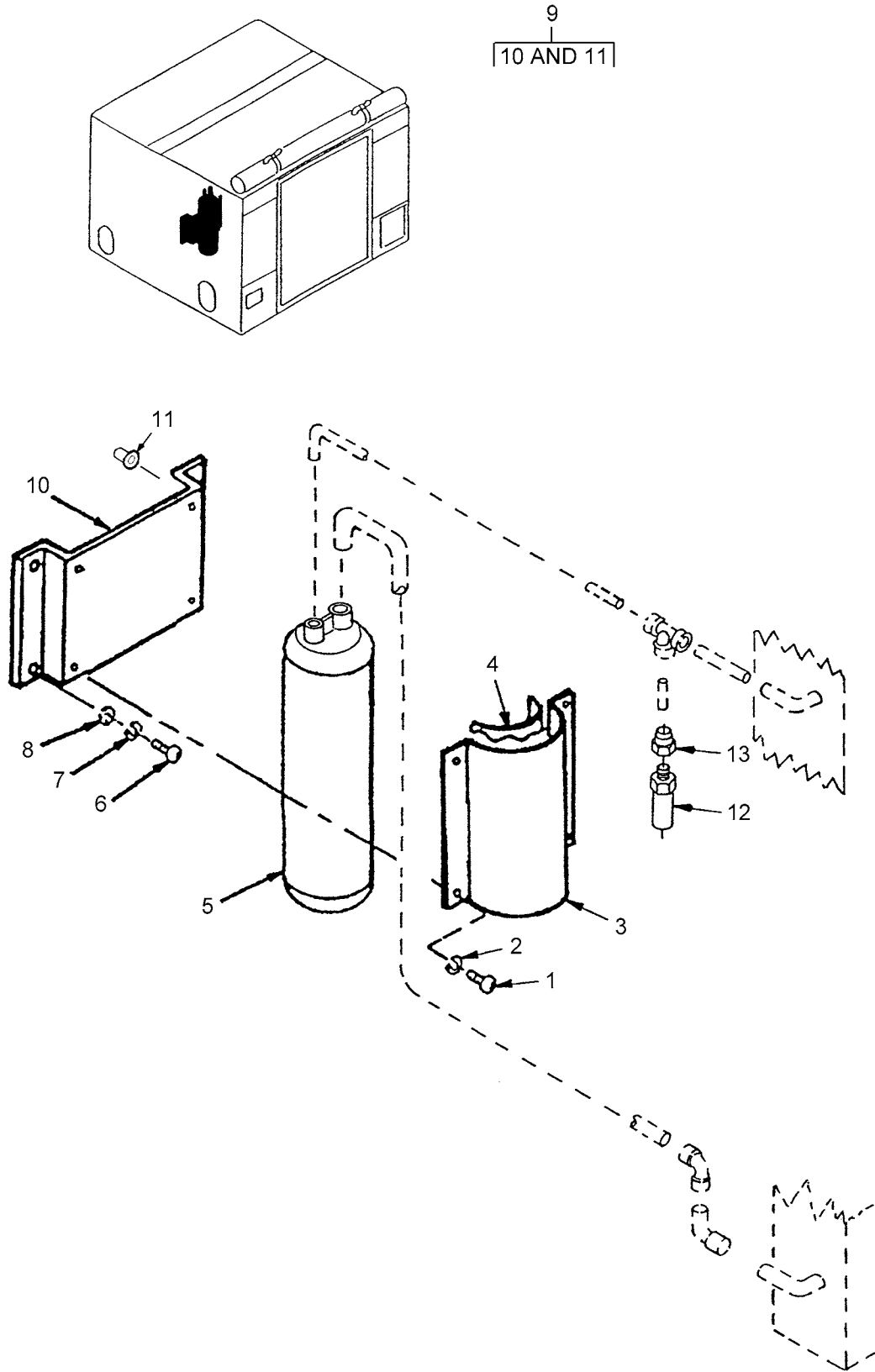

Figure 22. Receiver and Pressure Relief Valve

SECTION II			TM9-4120-425-14&P			
(1)	(2)	(3)	(4)	(5)	(6)	(7)
ITEM	SMR			PART		
NO	CODE	NSN	CAGEC	NUMBER	DESCRIPTION AND USABLE ON CODES(UOC)	QTY

GROUP 12 RECEIVER AND PRESSURE
RELIEF VALVE

FIGURE 22

1	PAFZZ	5305009931848	96906	MS35207-265	.SCREW,MACHINE.....	4
2	PAFZZ	5310000453296	96906	MS35338-43	.WASHER,LOCK.....	4
3	XBFZZ		0V5R4	S9500-6343	.CLAMP,RECEIVER.....	1
4	MFFZZ		0V5R4	S9500-22-4	.INSULATION,THERMAL MAKE FROM INSULATION, P/N ASTM-C534TP2,.500THK	1
5	PAFZZ		30756	932052	.RECEIVER.....	1
6	PAFZZ	5305009846194	80205	MS35206-246	.SCREW,MACHINE.....	4
7	PAFZZ	5310000453299	96906	MS35338-42	.WASHER,LOCK.....	4
8	PAFZZ	5310007653197	96906	MS27183-41	.WASHER,FLAT.....	4
9	XBFZZ		0V5R4	S9500-6715	.BRACKET,RECEIVER.....	1
10	XAFZZ		0V5R4	S9500-6715-1	..BRACKET.....	1
11	PAFZZ	5310010558419	96906	MS27130-S25K	..NUT,PLAIN,BLIND RIV.....	4
12	PAFZZ		28193	5221	.VALVE,SAFETY RELIEF.....	1
13	XDFZZ	4730007222381	97403	13216E6170	.ADAPTER,STRAIGHT,PI.....	1

END OF FIGURE

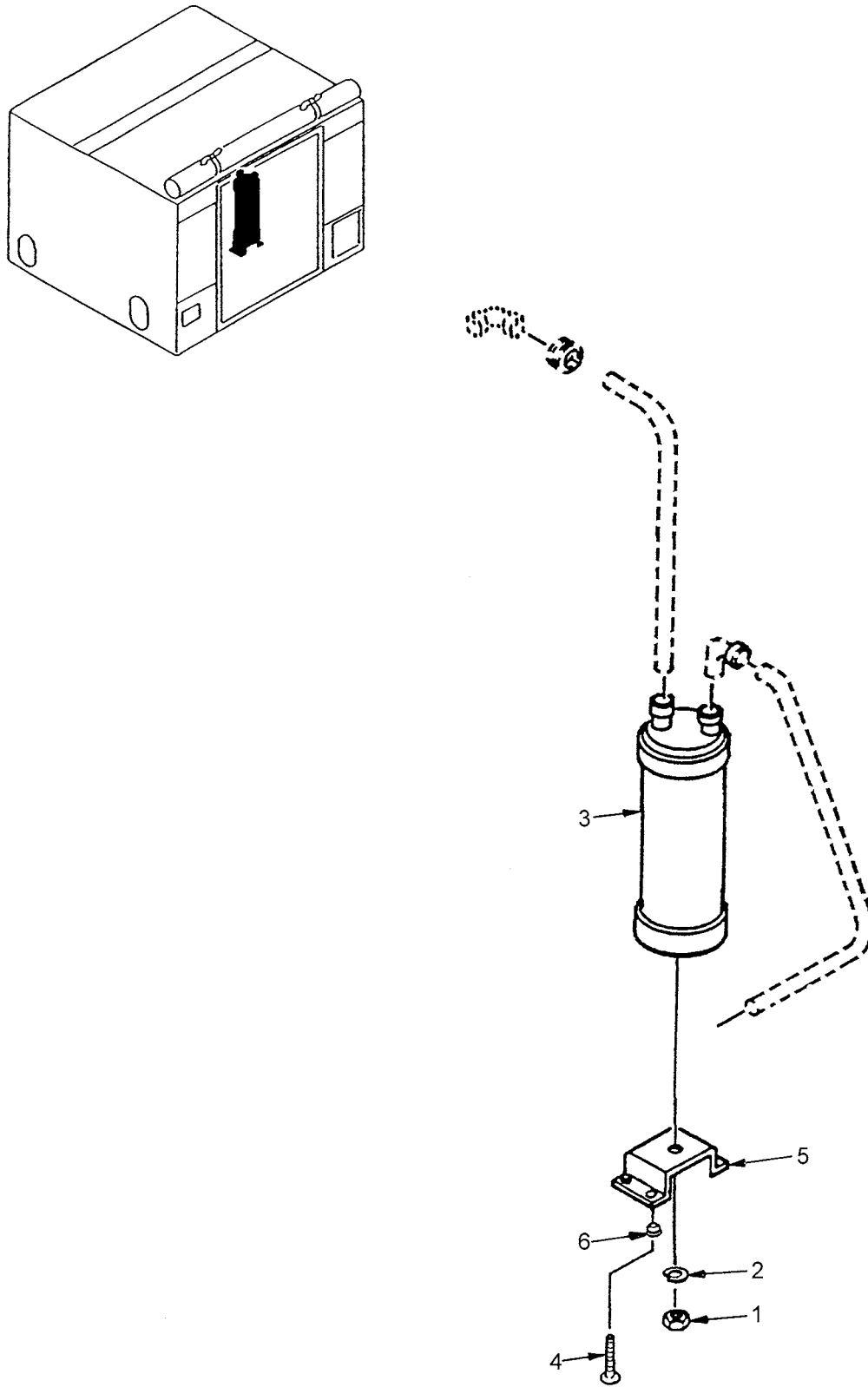

Figure 23. Accumulator

SECTION II			TM9-4120-425-14&P			
(1)	(2)	(3)	(4)	(5)	(6)	(7)
ITEM NO	SMR CODE	NSN	CAGEC	PART NUMBER	DESCRIPTION AND USABLE ON CODES(UOC) QTY	
					GROUP 12	ACCUMULATOR

FIGURE 23

1	PAFZZ	5310007320558	96906	MS51967-8	.NUT,PLAIN,HEXAGON.....	1
2	PAFZZ		96906	MS35338-46	.WASHER,LOCK.....	1
3	PAFZZ		70255	A-AS-597	.ACCUMULATOR,REFRIGE.....	1
4	PAFZZ	5305009577086	96906	MS24693-S273	.SCREW,MACHINE.....	4
5	XBFZZ		0V5R4	S9500-9556	.SUPPORT,ACCUMULATOR.....	1
6	PAFZZ	5310009931548	96906	MS27130-S133K	..NUT,PLAIN,BLIND RIV.....	4

END OF FIGURE

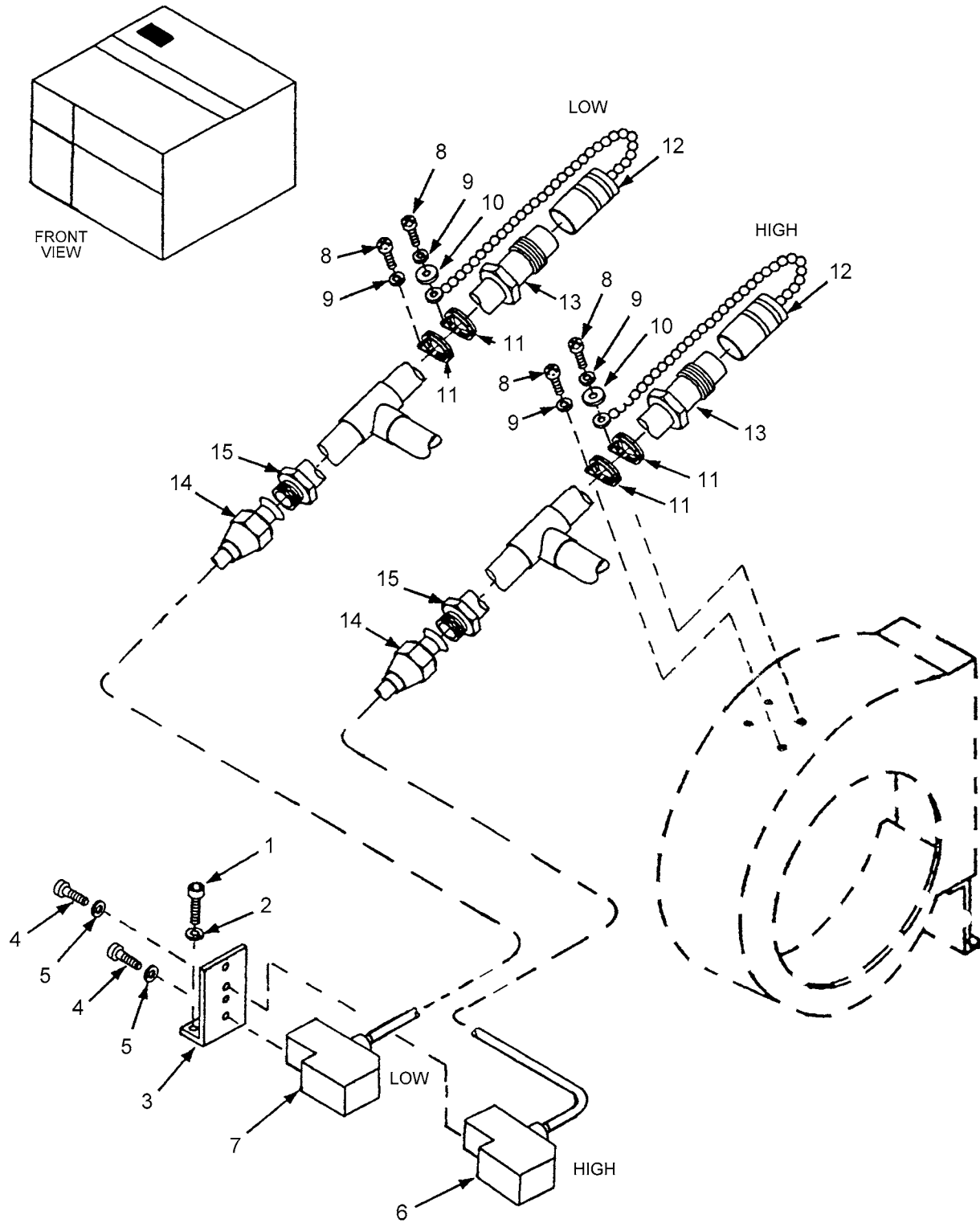

Figure 24. Pressure Switches and Service Valves

SECTION II			TM9-4120-425-14&P			
(1)	(2)	(3)	(4)	(5)	(6)	(7)
ITEM NO	SMR CODE	NSN	CAGEC	PART NUMBER	DESCRIPTION AND USABLE ON CODES(UOC)	QTY
					GROUP 12	PRESSURE SWITCHES AND SERVICE VALVES
FIGURE 24						
1	PAOZZ	5305009846194	80205	MS35206-246	.SCREW,MACHINE.....	2
2	PAOZZ	5310000453299	96906	MS35338-42	.WASHER,LOCK.....	2
3	PAOZZ		0V5R4	S9500-9944	.BRACKET HIGH.....	1
4	PAOZZ	5305009789348	96906	MS16997-20	.SCREW,MACHINE.....	4
5	PAOZZ	5310000454007	96906	MS35338-41	.WASHER,LOCK.....	4
6	PAFZZ	5930001908729	97403	13216E6215-3	.SWITCH,PRESSURE HIGH.....	1
7	PAFZZ	5930001908730	97403	13216E6215-1	.SWITCH,PRESSURE LOW.....	1
8	PAOZZ	5305009846194	80205	MS35206-246	.SCREW,MACHINE.....	4
9	PAOZZ	5310000453299	96906	MS35338-42	.WASHER,LOCK CAD PLTD,NO.8.....	4
10	PAOZZ	5310008212366	97403	13214E3469	.WASHER,FLAT CAD PLTD,NO.8.....	2
11	PAOZZ	5340005980146	96906	MS21919WDG6	.CLAMP,LOOP.....	4
12	PAOZZ	5935014668138	0V5R4	S9540	.COVER,ELECTRICAL CO.....	2
13	PAFZZ	4820010126437	17529	AV46	.VALVE,PNEUMATIC TAN.....	2
14	PBFZZ	4730001892737	96906	MS35872-2	.NUT,TUBE COUPLING.....	2
15	PBFZZ	4730010374919	96906	MS35919-22	.COUPLING,TUBE.....	2

END OF FIGURE

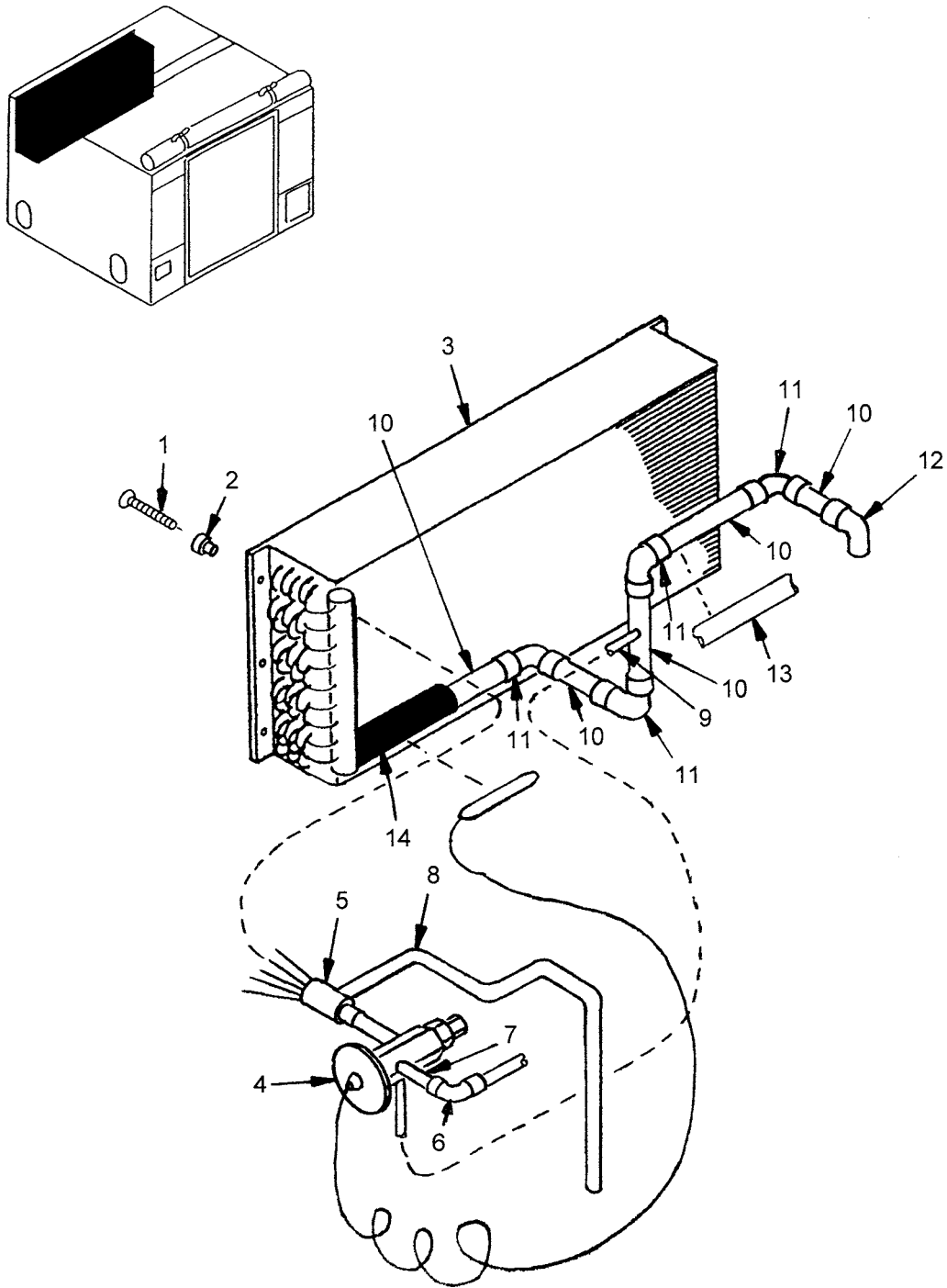

Figure 25. Evaporator Coil and Expansion Valve

SECTION II			TM9-4120-425-14&P			
(1)	(2)	(3)	(4)	(5)	(6)	(7)
ITEM NO	SMR CODE	NSN	CAGEC	PART NUMBER	DESCRIPTION AND USABLE ON CODES(UOC)	QTY
					GROUP 12 EVAPORATOR COIL AND EXPANSION VALVE	

FIGURE 25

1	PAFZZ	5305009931848	96906	MS35207-265	.SCREW,MACHINE.....	6
2	PAFZZ		96906	MS27130-S135K	.NUT,BLIND RIVET.....	6
3	PBFZZ		14852	3EY1204D	.COIL,EVAPORATOR.....	1
4	PAFZZ		70255	HNE3W100-12A	.VALVE,EXPANSION.....	1
5	XBFZZ		0V5R4	S9500-6345-1	.DISTRIBUTOR, REFRIGERENT (RESTRICTOR).....	1
6	PAFZZ		41947	W02305	.ELBOW,90DEG,3/8.....	1
7	MFFZZ		81346	ASTM-B280X.375OD	.TUBE,METALLIC MAKE FROM P/N ASTM- B280X.375OD (81346),CUT TO LENGTH...	1
8	MFFZZ	4710002775529	81346	ASTM-B280X.500OD	.TUBE,METALLIC MAKE FROM P/N ASTM- B280X.500OD (81346),CUT TO LENGTH...	1
9	MFFZZ		81346	ASTM-B280X.250OD	.TUBE,METALLIC MAKE FROM P/N ASTM- B280X.250OD (81346),CUT TO LENGTH...	1
10	MFFZZ		81346	ASTM-B280X.875OD	.TUBE,METALLIC MAKE FROM P/N ASTM- B280X.875OD (81346),CUT TO LENGTH...	5
11	PAFZZ	4730002546447	41947	W2034	.ELBOW,TUBE.....	4
12	PAFZZ	4730013286117	41947	W2334	.ELBOW,TUBE.....	1
14	PAOZZ		0V5R4	APT07838ASTME84T ESTMETHOD	.RUBBER INSULATION, BLACK, APARMAFLEX.....	V

END OF FIGURE

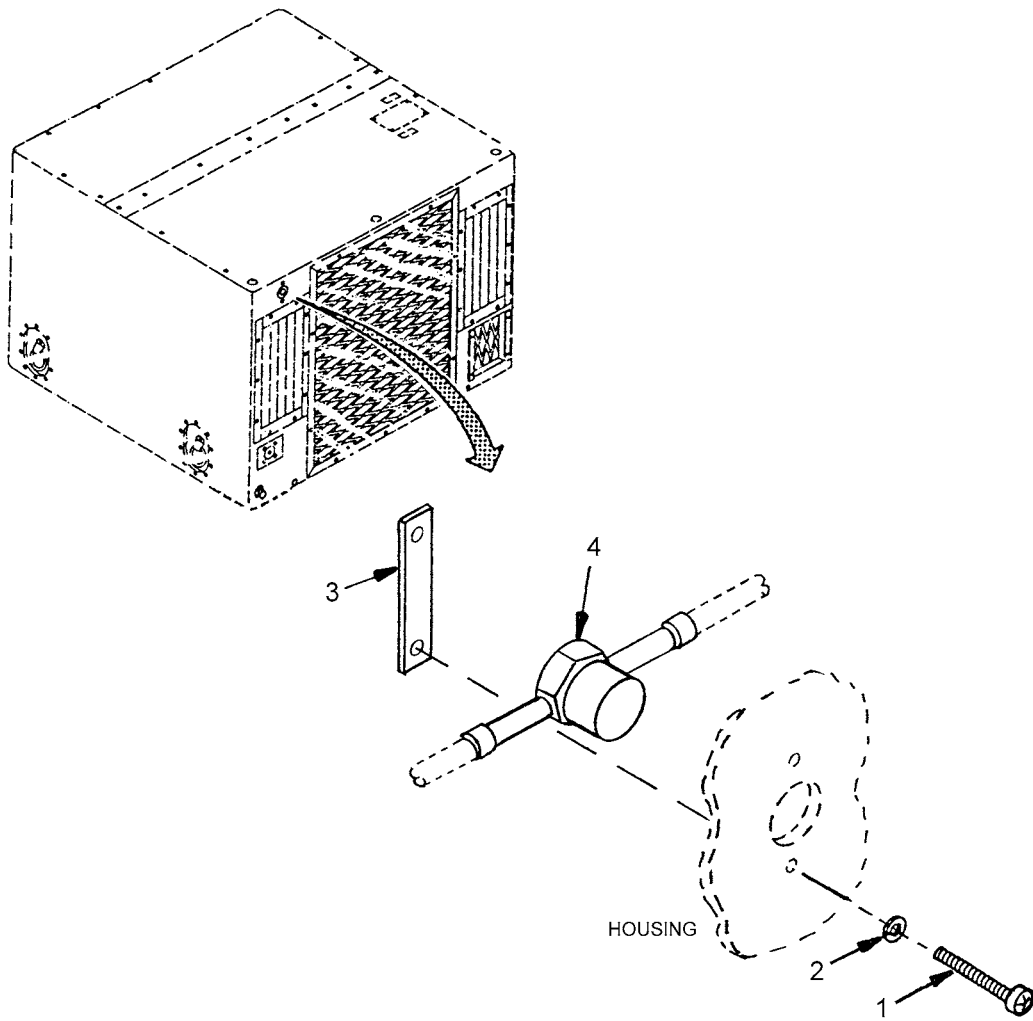

Figure 26. Liquid Sight Indicator

SECTION II			TM9-4120-425-14&P			
(1)	(2)	(3)	(4)	(5)	(6)	(7)
ITEM	SMR			PART		
NO	CODE	NSN	CAGEC	NUMBER	DESCRIPTION AND USABLE ON CODES(UOC)	QTY
					GROUP 12 LIQUID SIGHT INDICATOR	

FIGURE 26

1	PAOZZ	5305009846202	96906	MS35206-254	.SCREW,MACHINE.....	2
2	PAOZZ	5310000453299	96906	MS35338-42	.WASHER,LOCK.....	2
3	XBOZA	5340014670347	97403	13216E6156	.PLATE,MOUNTING.....	1
4	PAFZZ	6680007783914	97403	13216E6155-2	.INDICATOR,SIGHT,LIQ UID.....	1

END OF FIGURE

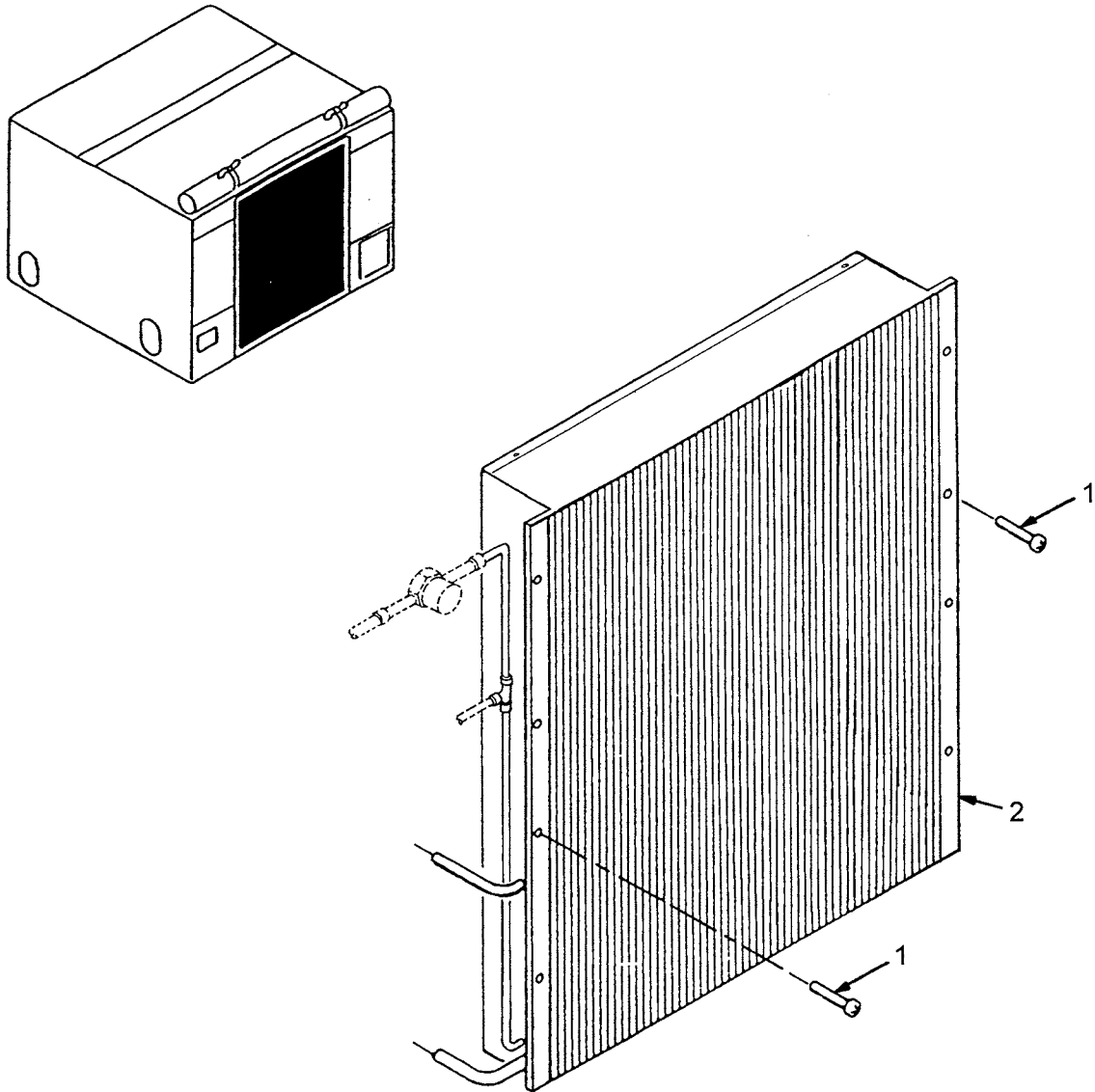

Figure 27. Condenser Coil

SECTION II			TM9-4120-425-14&P			
(1)	(2)	(3)	(4)	(5)	(6)	(7)
ITEM	SMR			PART		
NO	CODE	NSN	CAGEC	NUMBER	DESCRIPTION AND USABLE ON CODES(UOC)	QTY

GROUP 12 CONDENSER COIL

FIGURE 27

1	PAFZZ	5305009577086	96906	MS24693-S273	.SCREW,MACHINE.....	2
2	PAFZZ		14852	2CY1405E	.COIL,CONDENSER.....	1

END OF FIGURE

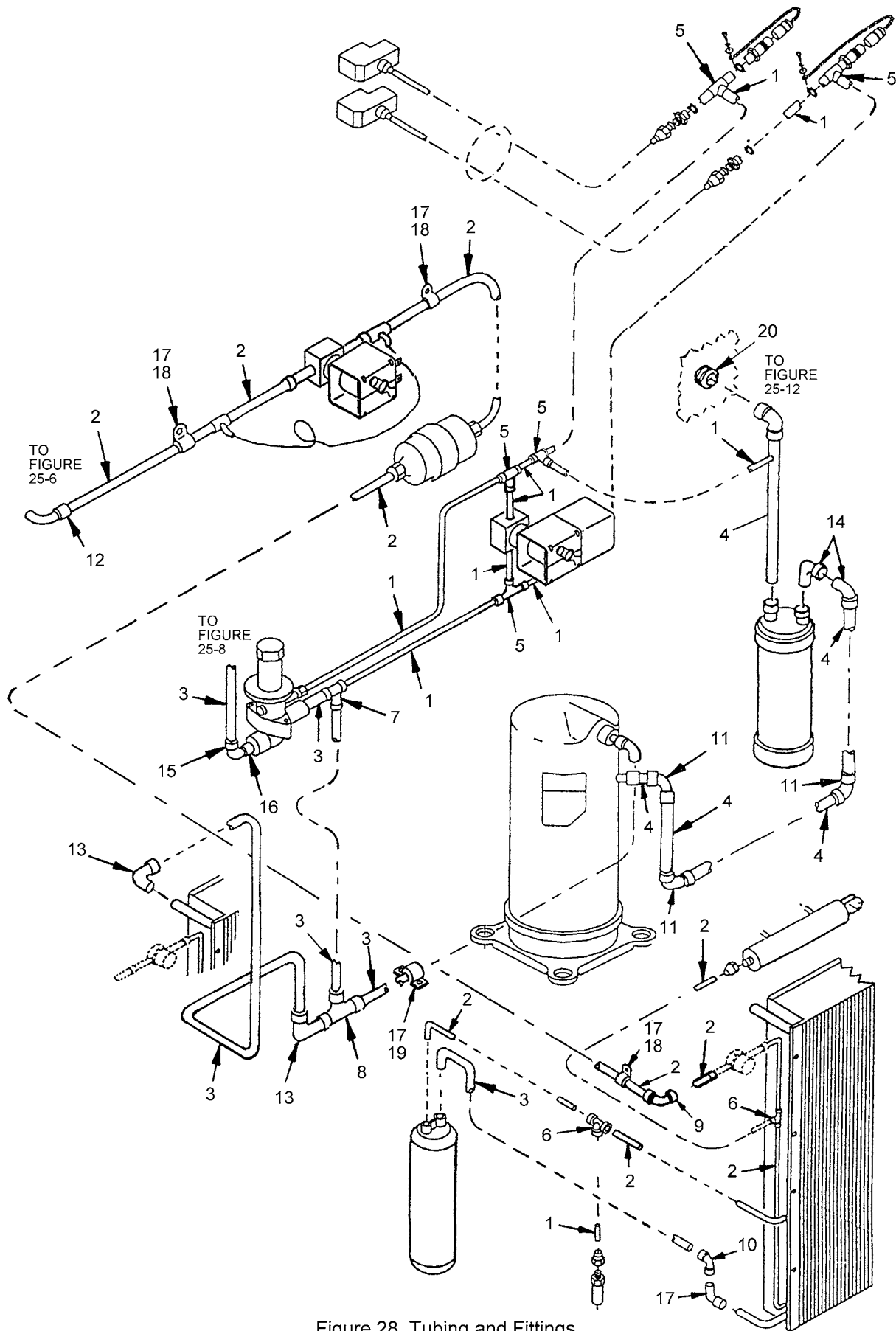

Figure 28. Tubing and Fittings

SECTION II			TM9-4120-425-14&P			
(1)	(2)	(3)	(4)	(5)	(6)	(7)
ITEM	SMR			PART		
NO	CODE	NSN	CAGEC	NUMBER	DESCRIPTION AND USABLE ON CODES(UOC)	QTY

GROUP 12 TUBING AND FITTINGS

FIGURE 28

1	MFFZZ		81346	ASTM-B280X.250OD	.TUBE,METALLIC MAKE FROM P/N ASTM-B280X.250OD (81346), CUT TO LENGTH..	8
2	MFFZZ		81346	ASTM-B280X.375OD	.TUBE,METALLIC MAKE FROM P/N ASTM-B280X.375OD (81346), CUT TO LENGTH..	8
3	MFFZZ	4710002775529	81346	ASTM-B280X.500OD	.TUBE,METALLIC MAKE FROM P/N ASTM-B280X.500OD (81346), CUT TO LENGTH..	6
4	MFFZZ		81346	ASTM-B280X.875OD	.TUBE,METALLIC MAKE FROM P/N ASTM-B280X.875OD (81346), CUT TO LENGTH..	5
5	PAFZZ	4730002572163	96906	MS35929-2	.TEE,TUBE 1/4 X 1/4 X 1/4.....	5
6	PAFZZ	4730008187778	41947	W-40324	.TEE,TUBE 1/4 X 3/8 X 3/8.....	1
7	PAFZZ	4730008155672	41947	W-40363	.TEE,TUBE 1/4 X 1/2 X 1/2.....	1
8	PAFZZ	4730002636465	41947	W-4001	.TEE,TUBE 1/2 X 1/2 X 1/2.....	1
9	PAFZZ	4730009407940	96906	MS35928-3	.ELBOW,TUBE 3/8 X 3/8 X 90 DEG.....	1
10	PAFZZ	4730002546449	41947	W2017	.ELBOW,TUBE 1/2 X 1/2 X 90 DEG.....	1
11	PAFZZ	4730002546447	96906	MS35917-7	.ELBOW,TUBE 7/8 X 7/8 X 90 DEG.....	3
12	PAFZZ	4730004715663	41947	W2716	.ELBOW,TUBE.....	1
13	PAFZZ	4730008133192	41947	W2817	.ELBOW,TUBE.....	2
14	PAFZZ	4730013286117	96906	MS35928-7	.ELBOW,TUBE.....	2
15	PAFZZ	4730002546449	41947	W2017	.ELBOW,TUBE.....	1
16	PAFZZ	4730008087878	41947	W1327	.REDUCER,TUBE.....	2
17	PAFZZ	5305009846194	80205	MS35206-246	.SCREW,MACHINE.....	8
18	PAFZZ	5340005980146	96906	MS21919DG6	.CLAMP,LOOP 3/8.....	3
19	PAFZZ	5340005980597	96906	MS21919DG8	.CLAMP,LOOP 1/2.....	1
20	PAFZZ	5325001716387	96906	MS35489-51	.GROMMET,NONMETALLIC.....	1

END OF FIGURE

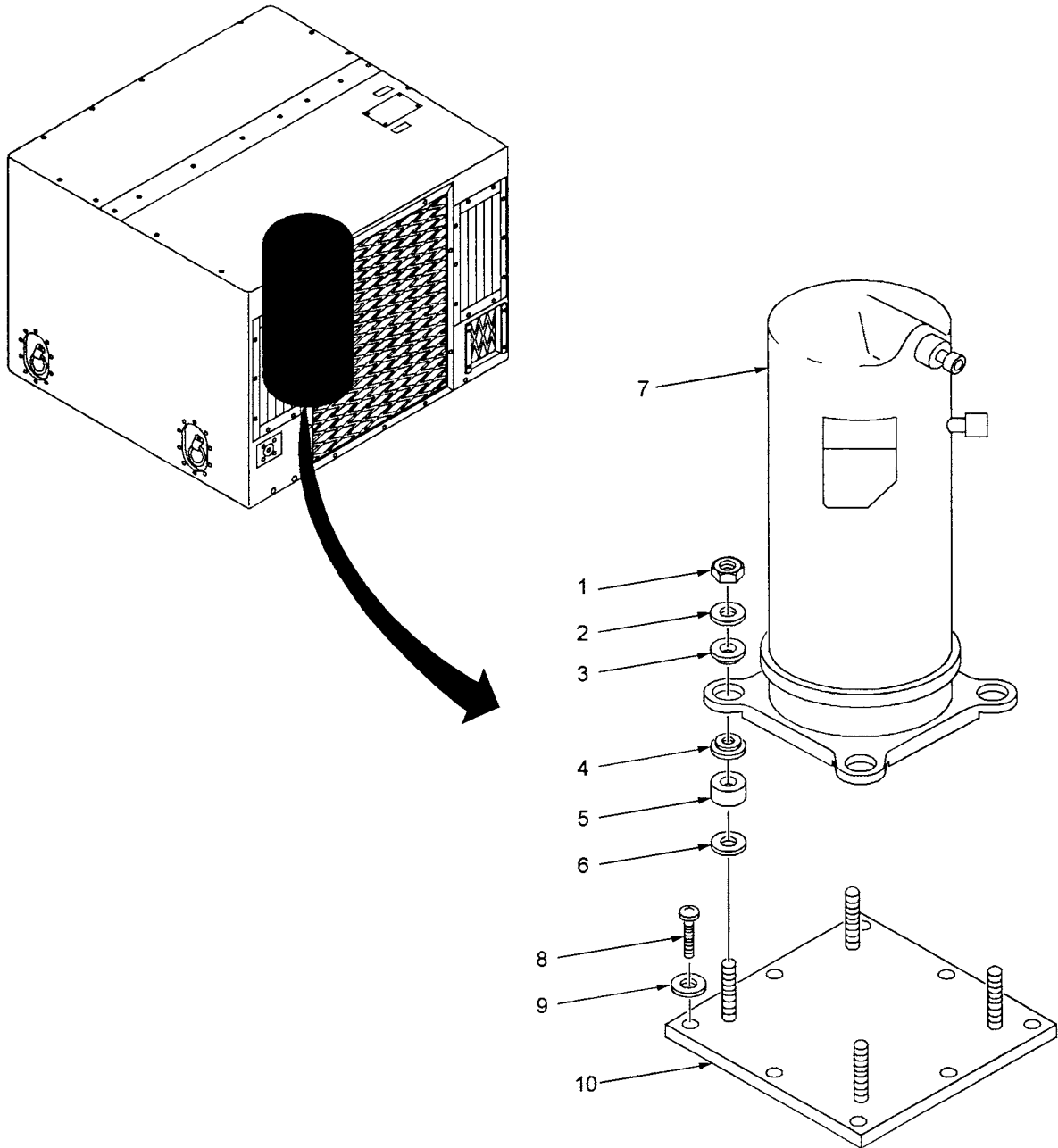

Figure 29. Compressor

SECTION II			TM9-4120-425-14&P			
(1)	(2)	(3)	(4)	(5)	(6)	(7)
ITEM	SMR			PART		
NO	CODE	NSN	CAGEC	NUMBER	DESCRIPTION AND USABLE ON CODES(UOC) QTY	

GROUP 13 COMPRESSOR

FIGURE 29

1	PAOZZ		0V5R4	S9500-3/8/16LK	.NUT.....	4
2	PAOZZ	5310000806004	96906	MS27183-14	.WASHER,FLAT.....	4
3	PAOZZ		0V5R4	S9500-8165-3	.GROMMET.....	4
4	PAFZZ	5342010425759	97403	13216E6137	.MOUNT,RESILIENT,WEA.....	4
5	PAFZZ		0V5R4	S9500-8165-1	.SPACER.....	4
6	PAFZZ		0V5R4	S9500-8165-2	.SPACER,RUBBER.....	4
7	PAFZZ		14569	ZR46KC-TF5	.COMPRESSOR.....	1
8	PAFZZ		96906	MS35312-10	.SCREW,MACHINE.....	8
9	PAFZZ	5310001670767	88044	AN970-5	.WASHER,FLAT.....	8
10	PAFZZ		0V5R4	S9500-9918	.PLATE,MOUNTING, COMPRESSOR.....	1

END OF FIGURE

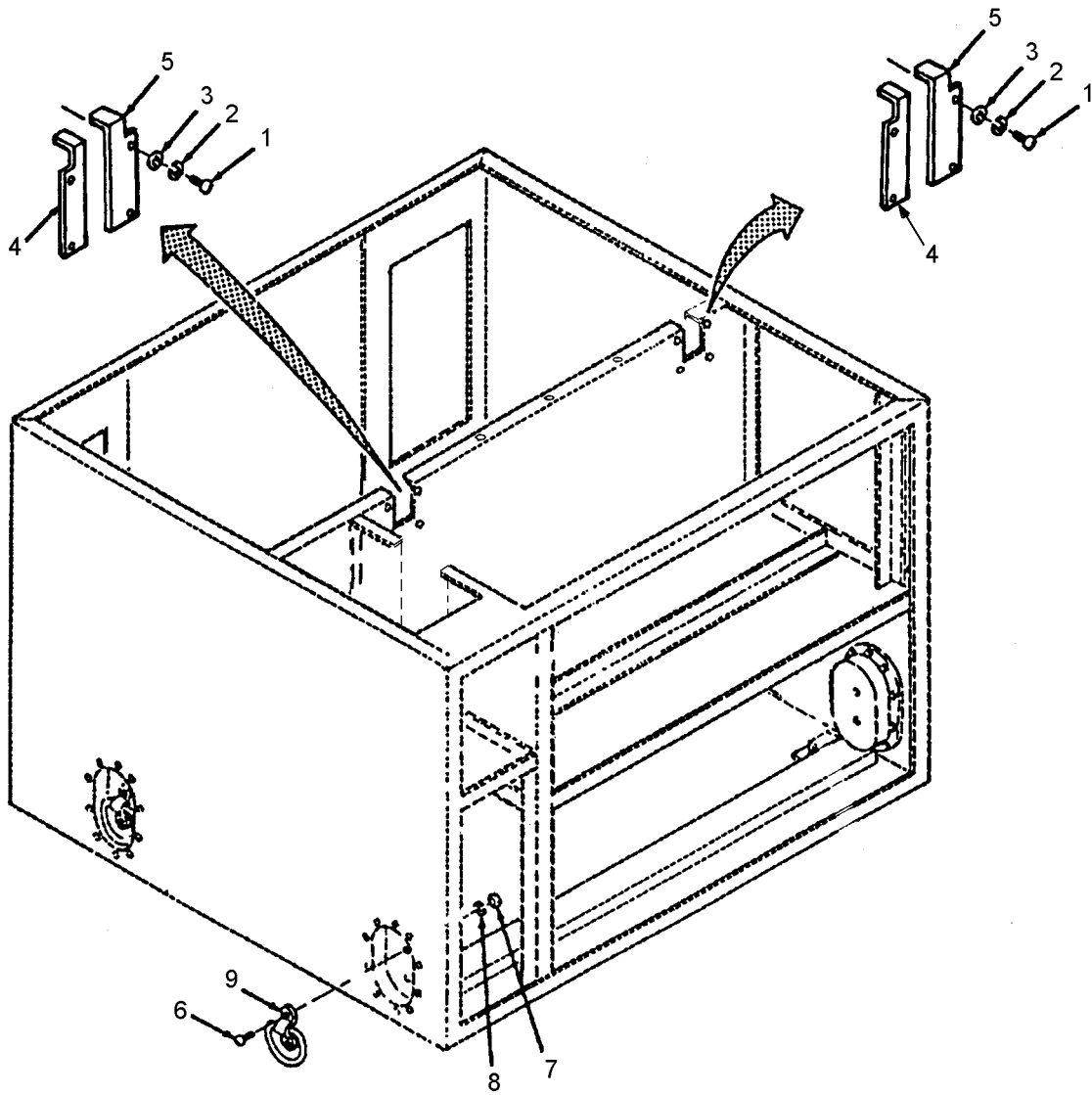

Figure 30. Housing (Sheet 1 of 2)

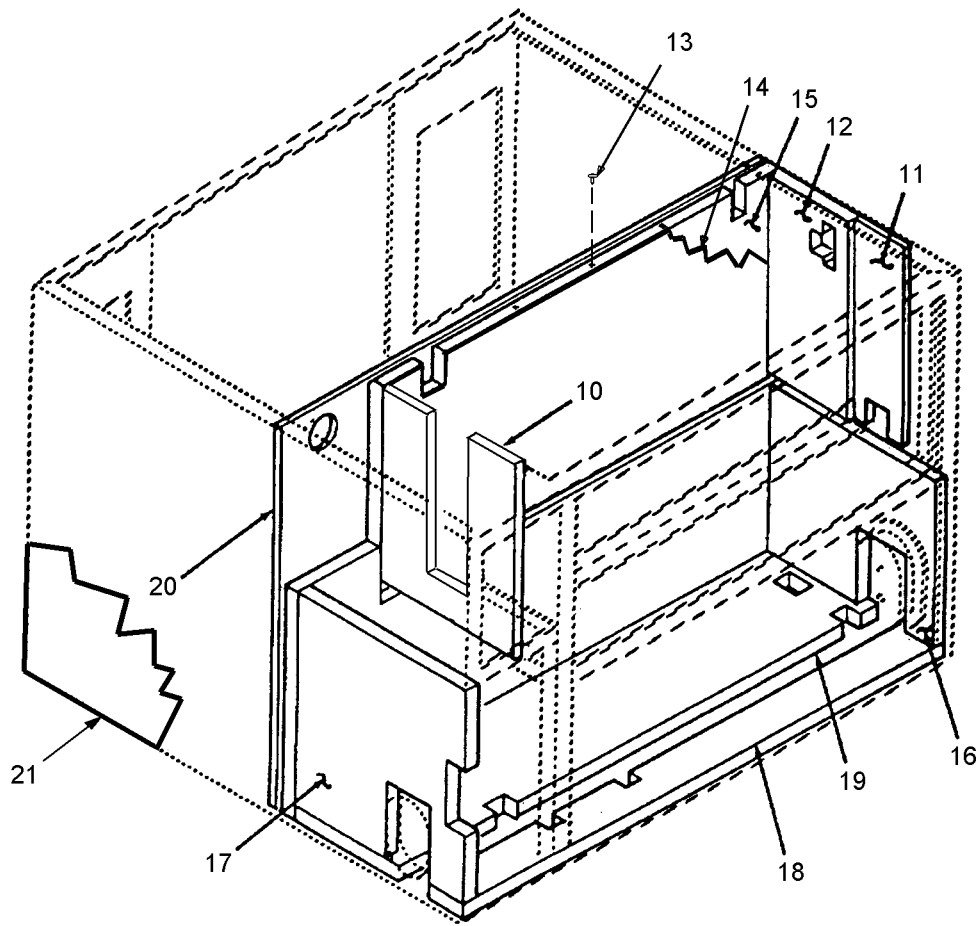

Figure 30. Housing (Sheet 2 of 2)

SECTION II			TM9-4120-425-14&P			
(1)	(2)	(3)	(4)	(5)	(6)	(7)
ITEM	SMR			PART		
NO	CODE	NSN	CAGEC	NUMBER	DESCRIPTION AND USABLE ON CODES(UOC)	QTY

GROUP 14 HOUSING

FIGURE 30

1	PAHZZ	5305009846194	80205	MS35206-246	.SCREW,MACHINE.....	8
2	PAHZZ	5310000453299	96906	MS35338-42	.WASHER,LOCK.....	8
3	PAHZZ	5310008098544	96906	MS27183-7	.WASHER,FLAT.....	8
4	XBHZZ		0V5R4	S9500-6667	.PLATE,BLOCK OFF LEFT.....	2
5	XBHZZ		0V5R4	S9500-6666	.PLATE,BLOCK OFF RIGHT.....	2
6	PAHZZ		96906	MS90726-32	.BOLT,MACHINE.....	8
7	PAHZZ	5310000544892	96906	MS35650-3312	.NUT,PLAIN,HEXAGON.....	8
8	PAHZZ	5310004079566	96906	MS35338-45	.WASHER,LOCK.....	8
9	PAHZZ	5365011107314	97403	13216E6360	.RING,DEE.....	4
10	MHHZZ		0V5R4	S9500-6701/77	.INSULATION,THERMAL MAKE FROM INSULATION, P/N ASTM-C534TP2,.75THK.	1
11	MHHZZ		0V5R4	S9500-6701/79	.INSULATION,THERMAL MAKE FROM INSULATION, P/N ASTM-C534TP2,.75THK.	1
12	MHHZZ		0V5R4	S9500-6701/80	.INSULATION,THERMAL MAKE FROM INSULATION, P/N ASTM-C534TP2,1.0THK.	1
13	XBHZZ	5320001196754	96906	MS20470AD2-3	.RIVET,SOLID.....	4
14	XBHZZ		0V5R4	S9500-30-19	.HEAT SHIELD.....	1
15	MHHZZ		0V5R4	S9500-6701/81	.INSULATION,THERMAL MAKE FROM INSULATION, P/N ASTM-C534TP2,1.0THK.	1
16	MHHZZ		0V5R4	S9500-6701/82	.INSULATION,THERMAL MAKE FROM INSULATION, P/N ASTM-C534TP2,.75THK.	1
17	MHHZZ		0V5R4	S9500-6701/83	.INSULATION,THERMAL MAKE FROM INSULATION, P/N ASTM-C534TP2,.75THK.	1
18	MHHZZ		0V5R4	S9500-6701/84	.INSULATION,THERMAL MAKE FROM INSULATION, P/N ASTM-C534TP2,1.0THK.	1
19	MHHZZ		0V5R4	S9500-6701/85	.INSULATION,THERMAL MAKE FROM INSULATION, P/N ASTM-C534TP2,1.0THK.	1
20	MHHZZ		0V5R4	S9500-6701/86	.INSULATION,THERMAL MAKE FROM INSULATION, P/N ASTM-C534TP2,.75THK.	1
21	XBHZZ		0V5R4	S9500-6701	.HOUSING.....	1

END OF FIGURE

SECTION II			TM9-4120-425-14&P			
(1)	(2)	(3)	(4)	(5)	(6)	(7)
ITEM NO	SMR CODE	NSN	CAGEC	PART NUMBER	DESCRIPTION AND USABLE ON CODES(UOC)	QTY
BULK ITEMS LIST						
1	PAOZZ		81346	ASTM-C534TP2X.060	INSULATION, THERMAL.....	V
2	PAOZZ		81346	ASTM-C534TP2X.125	INSULATION, THERMAL.....	V
3	PAOZZ		81346	ASTM-C534TP2X.250	INSULATION, THERMAL.....	V
4	PAOZZ		81346	ASTM-C534TP2X.500	INSULATION, THERMAL.....	V
5	PAOZZ		81346	ASTM-C534TP2X.750	INSULATION, THERMAL.....	V
6	PAOZZ		81346	ASTM-C534TP2X1.00	INSULATION, THERMAL.....	V
7	PAOZZ	5970000823942	81349	M23053/5-105-9	INSULATION SLEEVING.....	V
8	PAOZZ	5970000882975	81349	M23053/5-104-9	INSULATION SLEEVING.....	V
9	PAOZZ	59700008142878	81349	M23053/5-106-9	INSULATION SLEEVING.....	V
10	PAOZZ		0V5R4	APT07838ASTME84T ESTMETHOD	RUBBER INSULATION, BLACK, APARMAFLEX.....	V
11	PAFZZ		81346	ASTM-B280X.250OD	TUBE, METALLIC.....	V
12	PAFZZ		81346	ASTM-B280X.375OD	TUBE, METALLIC.....	V
13	PAFZZ	4710002775529	81346	ASTM-B280X.500OD	TUBE, METALLIC.....	V
14	PAFZZ		81346	ASTM-B280X.875OD	TUBE, METALLIC.....	V
15	PAOZZ		81349	ZZ-T-831TYPEVICL ASS6	TUBING, PLASTIC .625 IN. ID.....	V
16	PAOZZ	6145005787513	81349	M5086/2-10-9	WIRE, ELECTRICAL.....	V
17	PAOZZ	6145005786604	81349	M5086/2-14-9	WIRE, ELECTRICAL.....	V
18	PAOZZ	6145008518505	81349	M5086/2-20-9	WIRE, ELECTRICAL.....	V

END OF FIGURE

SECTION IV

TM9-4120-425-14&P

CROSS-REFERENCE INDEXES

NATIONAL STOCK NUMBER INDEX					
STOCK NUMBER	FIG.	ITEM	STOCK NUMBER	FIG.	ITEM
5310-00-012-0560	11	13	5320-00-119-6754	2	1
5310-00-014-5850	1	3	5940-00-143-4771	18	4
	9	2	5940-00-143-4794	18	11
	10	29	5940-00-144-2433	18	10
	13	3	4820-00-165-0963	20	5
5310-00-045-3296	1	2	5310-00-167-0767	10	3
	4	11		29	9
	5	10	5325-00-171-6387	28	20
	9	5	5325-00-174-5317	10	8
	10	46		13	18
	10	54	5325-00-185-0012	16	26
	12	3	5325-00-185-0017	10	9
	13	2	4730-00-189-2737	24	14
	13	24	4730-00-189-2739	19	4
	14	2	5930-00-190-8729	24	6
	16	2	5930-00-190-8730	24	7
	22	2	4710-00-203-3172	BULK	12
5310-00-045-3299	4	2	5310-00-209-0786	16	36
	5	2	4730-00-254-6447	25	11
	11	6		28	11
	13	12	4730-00-254-6449	28	10
	14	4		28	15
	16	15	4730-00-257-2163	28	5
	17	3	4730-00-263-6465	28	8
	22	7	5325-00-276-4931	1	11
	24	2	4710-00-277-5529	BULK	13
	24	9	5310-00-404-1433	6	2
	26	2		7	2
	30	2	5310-00-407-9566	10	2
5310-00-045-4007	13	20		30	8
	24	5	4730-00-471-5663	28	12
5305-00-051-2355	17	1	4130-00-479-2744	21	3
	17	8	5935-00-490-3743	14	34
5310-00-054-4892	30	7	5310-00-543-2410	15	6
5305-00-063-3503	19	1	5310-00-543-5060	14	32
5305-00-063-3507	3	1		15	18
5330-00-063-7889	14	43	5355-00-556-0145	15	8
5305-00-068-0516	16	34		15	9
5310-00-080-6004	29	2	5325-00-558-8826	6	12
5310-00-081-4219	9	18		7	12
5970-00-082-3942	BULK	7	6145-00-578-6604	BULK	17
5310-00-087-0057	15	17	6145-00-578-7513	BULK	16
5310-00-088-0553	9	19	5310-00-582-5965	10	39
	10	1		10	49
5310-00-088-1251	15	4		21	2
5970-00-088-2975	BULK	8	5310-00-596-7693	14	17
5975-00-111-3208	11	16	5340-00-598-0146	12	9
	15	20		24	11
5320-00-117-6828	10	16		28	18
	10	23	5340-00-598-0597	28	19

SECTION IV

TM9-4120-425-14&P

CROSS-REFERENCE INDEXES

NATIONAL STOCK NUMBER INDEX						
STOCK NUMBER	FIG.	ITEM	STOCK NUMBER	FIG.	ITEM	
5310-00-616-2589	13	14	5305-00-889-2997	15	5	
	14	36	5305-00-889-2999	14	40	
	16	10	5305-00-889-3000	14	28	
	16	30	5305-00-889-3001	14	24	
	16	33	4730-00-908-3194	8	13	
5305-00-719-5007	10	47	4730-00-908-3195	8	1	
5310-00-727-8353	14	20	5310-00-914-3290	12	25	
5310-00-732-0558	23	1		14	23	
5310-00-765-3197	9	9	5310-00-934-9738	14	33	
	17	4		15	12	
	22	8	5310-00-934-9757	17	2	
5310-00-777-5787	10	15	4730-00-940-7940	28	9	
	10	22	5310-00-950-0039	14	25	
	6680-00-778-3914	26	4	5310-00-950-1310	15	7
4730-00-808-7878	28	16	5305-00-954-0942	14	3	
5310-00-809-4058	9	23	5305-00-957-7086	23	4	
	10	40		27	1	
	15	3	5305-00-957-7817	6	7	
	16	35		7	7	
	5310-00-809-8544	10	7	5305-00-957-7820	16	21
	16	16	5305-00-957-7821	17	7	
	30	3		17	10	
4730-00-813-3192	28	13	5310-00-958-5321	3	9	
5970-00-814-2878	BULK	9		12	17	
5315-00-815-1405	6	1	5305-00-958-5473	14	5	
	7	1		14	8	
4730-00-815-5672	28	7	5305-00-958-5474	14	16	
4730-00-818-7778	28	6		15	26	
5310-00-820-6653	15	27	5305-00-958-6373	1	12	
5310-00-821-2366	24	10		2	17	
5315-00-839-2325	12	14	5305-00-958-6381	15	2	
6145-00-851-8505	BULK	18	5305-00-965-5879	10	57	
5310-00-857-4957	14	29	5305-00-978-9348	24	4	
5320-00-874-4477	10	14	5305-00-978-9350	13	19	
	10	21	5305-00-983-6730	14	41	
5310-00-877-5795	12	4	5305-00-984-4984	14	19	
	12	7	5305-00-984-6191	11	3	
	12	12		14	12	
	12	19		16	6	
	14	13	5305-00-984-6192	9	8	
	14	18	5305-00-984-6193	12	6	
	15	28		12	11	
	9	22		12	18	
	5310-00-877-5796	5	3		12	23
	5310-00-877-5797	9	3	5305-00-984-6194	4	1
	10	28		5	1	
	16	25		11	5	
5320-00-879-6606	6	4		12	1	
	7	4		12	2	
	5320-00-882-8385	4	5	12	5	

SECTION IV

TM9-4120-425-14&P

CROSS-REFERENCE INDEXES

STOCK NUMBER	NATIONAL STOCK NUMBER INDEX		STOCK NUMBER	FIG.	ITEM	
	FIG.	ITEM				
5305-00-984-6194	13	11	5310-01-055-8419	22	11	
	16	11	4130-01-098-6649	11	14	
	16	18	5310-01-100-5202	13	26	
	22	6		16	31	
	24	1	5365-01-110-7314	30	9	
	24	8	4130-01-123-9112	4	12	
	28	17	5940-01-139-0853	18	9	
	30	1	5310-01-146-9773	11	8	
	5305-00-984-6195	10	32		11	12
		11	1	5935-01-175-8417	14	42
5305-00-984-6196	10	6	5935-01-176-1708	14	26	
5305-00-984-6202	26	1	5940-01-201-7221	16	23	
5305-00-988-1167	14	31	5310-01-313-3977	10	41	
	15	16	5310-01-324-7187	10	44	
5305-00-988-1727	10	48		10	56	
5305-00-989-7435	5	4	4810-01-327-7651	20	1	
	9	1	4730-01-328-6117	25	12	
	10	45		28	14	
	14	1	9905-01-348-0495	16	22	
	16	1	5940-01-350-4066	18	12	
	16	4	5975-01-362-7144	14	39	
	16	8	5930-01-466-6331	15	10	
	16	24	5935-01-466-8138	24	12	
	16	27	5935-01-470-8413	15	21	
	5310-00-993-1548	14	37	5340-01-475-8943	11	2
		23	6	4730-01-475-9640	8	8
	5305-00-993-1848	4	10	4520-01-476-2807	13	6
		9	4			
		10	27			
10		53				
13		1				
22		1				
25		1				
5305-00-993-1851		13	23			
5305-00-993-2459		10	38			
5305-00-995-3444		5	9			
5310-00-997-1888	21	1				
5310-01-011-7989	15	15				
4820-01-012-6437	24	13				
3110-01-028-6816	6	14				
	7	14				
3110-01-028-6817	6	13				
	7	13				
4730-01-037-4919	24	15				
5342-01-042-5759	29	4				
5310-01-047-9470	10	31				
5310-01-048-0553	13	27				
	14	10				
5310-01-055-8419	10	18				
	10	25				

SECTION IV

TM9-4120-425-14&P

CROSS-REFERENCE INDEXES

CAGEC	PART NUMBER	PART NUMBER INDEX		FIG.	ITEM
			STOCK NUMBER		
70255	A-AS-597			23	3
52516	AH4101			15	11
70255	AMG208/220			20	4
70255	AMS24-50/60			20	2
88044	AN970-5		5310-00-167-0767	10	3
				29	9
0V5R4	APT07838ASTME84T ESTMETHOD			25	14
				BULK	10
81346	ASTM-B280X.250OD			25	9
				28	1
				BULK	11
81346	ASTM-B280X.375OD			25	7
				28	2
			4710-00-203-3172	BULK	12
81346	ASTM-B280X.500OD			25	8
				28	3
			4710-00-277-5529	BULK	13
81346	ASTM-B280X.875OD			25	10
				28	4
				BULK	14
81346	ASTM-C534TP2X.06 0			BULK	1
81346	ASTM-C534TP2X.12 5			BULK	2
81346	ASTM-C534TP2X.25 0			BULK	3
81346	ASTM-C534TP2X.50 0			BULK	4
81346	ASTM-C534TP2X.75 0			BULK	5
81346	ASTM-C534TP2X1.0 0			BULK	6
17529	AV46		4820-01-012-6437	24	13
06383	BSV14X		5940-00-144-2433	18	10
80204	B1821BH025F113N		5305-00-068-0516	16	34
71389	CA3102E24-10PB			14	14
71389	CA3106E24-10SB			14	15
70255	CPHE4		4820-00-165-0963	20	5
0V5R4	C4D0304N-9833		5930-01-466-6331	15	10
06383	DNFR18-250FIB			18	6
06383	DNF14-250FIM		5940-01-139-0853	18	9
06383	DNF18-250FIB			18	5
06383	DV18-250MB			18	7
52516	HMPS24A9X60			16	17
70255	HNE3W100-12A			25	4
82755	JA3S-K3-0040-02E			14	21
06383	JN418-212		5940-01-350-4066	18	12
83330	K21006-CB			13	16
83330	K21006-101			13	17
81349	MIL-W-27265			1	6

I-1

SECTION IV

TM9-4120-425-14&P

CROSS-REFERENCE INDEXES

CAGEC	PART NUMBER	PART NUMBER INDEX		FIG.	ITEM
			STOCK NUMBER		
96906	MS-35206-217		5305-00-889-2999	14	40
96906	MS16535-154		5320-00-879-6606	6	4
				7	4
96906	MS16997-20		5305-00-978-9348	24	4
96906	MS16997-22		5305-00-978-9350	13	19
96906	MS17188-1		5310-00-404-1433	6	2
				7	2
96906	MS20470AD2-3		5320-00-119-6754	2	1
				30	13
96906	MS20470AD4-6		5320-00-117-6828	10	16
				10	23
96906	MS21044-N6		5310-00-950-0039	14	25
80205	MS21044D6		5310-00-857-4957	14	29
96906	MS21044N3		5310-00-877-5797	5	3
				9	3
				10	28
				16	25
96906	MS21044N4		5310-00-877-5796	9	22
96906	MS21044N5		5310-00-088-0553	9	19
				10	1
96906	MS21044N8		5310-00-877-5795	12	4
				12	7
				12	12
				12	19
				14	13
				14	18
				15	28
96906	MS21059-L08		5310-00-777-5787	10	15
				10	22
96906	MS21076L4N		5310-01-313-3977	10	41
96906	MS21209C0620		5325-00-558-8826	6	12
				7	12
96906	MS21919DG6		5340-00-598-0146	28	18
96906	MS21919DG8		5340-00-598-0597	28	19
96906	MS21919WDG48			19	2
96906	MS21919WDG6		5340-00-598-0146	12	9
				24	11
96906	MS24665-132		5315-00-839-2325	12	14
96906	MS24665-151		5315-00-815-1405	6	1
				7	1
96906	MS24693-S26		5305-00-957-7817	6	7
				7	7
96906	MS24693-S273		5305-00-957-7086	23	4
				27	1
96906	MS24693-S274		5305-00-063-3507	3	1
96906	MS24693-S275		5305-00-965-5879	10	57
96906	MS24693-S31		5305-00-957-7820	16	21
96906	MS24693-S50		5305-00-063-3503	19	1
96906	MS24693-S51		5305-00-958-6373	1	12
				2	17
96906	MS24693-S54		5305-00-957-7821	17	7

SECTION IV

TM9-4120-425-14&P

CROSS-REFERENCE INDEXES

CAGEC	PART NUMBER	PART NUMBER INDEX		FIG.	ITEM
			STOCK NUMBER		
96906	MS24693-S54		5305-00-957-7821	17	10
96906	MS24693-S60		5305-00-051-2355	17	1
				17	8
96906	MS24693-118			9	17
96906	MS24693-256			16	14
96906	MS24693-304			9	21
96906	MS25043-22DA		5935-01-176-1708	14	26
96906	MS25043-24DA		5935-01-175-8417	14	42
96906	MS27130-S101K		5310-00-914-3290	12	25
				14	23
96906	MS27130-S127K		5310-01-324-7187	10	44
				10	56
96906	MS27130-S133K		5310-00-993-1548	14	37
				23	6
96906	MS27130-S135K			25	2
96906	MS27130-S25K		5310-01-055-8419	10	18
				10	25
				22	11
96906	MS27130-S26K		5310-00-958-5321	3	9
				12	17
96906	MS27130-S50K			16	37
96906	MS27130-S87K		5310-01-048-0553	13	27
				14	10
96906	MS27130-S93K		5310-00-616-2589	13	14
				14	36
				16	10
				16	30
				16	33
96906	MS27130-S94K		5310-01-146-9773	11	8
				11	12
96906	MS27130-S99K		5310-01-100-5202	13	26
				16	31
96906	MS27183-10		5310-00-809-4058	9	23
				10	40
				15	3
				16	35
96906	MS27183-12		5310-00-081-4219	9	18
96906	MS27183-14		5310-00-080-6004	29	2
96906	MS27183-2		5310-00-087-0057	15	17
96906	MS27183-4		5310-00-950-1310	15	7
96906	MS27183-41		5310-00-765-3197	9	9
				17	4
				22	8
96906	MS27183-42		5310-00-014-5850	1	3
				9	2
				10	29
				13	3
96906	MS27183-43		5310-00-727-8353	14	20
96906	MS27183-7		5310-00-809-8544	10	7
				16	16
				30	3

SECTION IV

TM9-4120-425-14&P

CROSS-REFERENCE INDEXES

CAGEC	PART NUMBER	PART NUMBER INDEX		FIG.	ITEM
			STOCK NUMBER		
96906	MS27980-1N			1	9
96906	MS27980-18N		5325-00-276-4931	1	11
96906	MS27980-6N			1	10
96906	MS3367-5-9		5975-00-111-3208	11	16
				15	20
96906	MS35190-250		5305-00-958-5474	14	16
				15	26
96906	MS35190-251		5305-00-958-5473	14	5
				14	8
96906	MS35203-44			13	15
96906	MS35206-204		5305-00-988-1167	14	31
				15	16
96906	MS35206-208		5305-00-958-6381	15	2
96906	MS35206-215		5305-00-889-2997	15	5
96906	MS35206-218		5305-00-983-6730	14	41
96906	MS35206-227		5305-00-984-4984	14	19
96906	MS35206-230		5305-00-889-3000	14	28
96906	MS35206-231		5305-00-889-3001	14	24
96906	MS35206-243		5305-00-984-6191	11	3
				14	12
				16	6
96906	MS35206-244		5305-00-984-6192	9	8
96906	MS35206-245		5305-00-984-6193	12	6
				12	11
				12	18
				12	23
80205	MS35206-246		5305-00-984-6194	4	1
				5	1
				11	5
				12	1
				12	2
				12	5
				13	11
				16	11
				16	18
				22	6
				24	1
				24	8
				28	17
				30	1
96906	MS35206-247		5305-00-984-6195	10	32
				11	1
96906	MS35206-248		5305-00-984-6196	10	6
96906	MS35206-254		5305-00-984-6202	26	1
96906	MS35206-283		5305-00-988-1727	10	48
96906	MS35206-331		5305-00-954-0942	14	3
96906	MS35207-264		5305-00-989-7435	5	4
				9	1
				10	45
				14	1
				16	1

SECTION IV

TM9-4120-425-14&P

CROSS-REFERENCE INDEXES

CAGEC	PART NUMBER	PART NUMBER INDEX		FIG.	ITEM
			STOCK NUMBER		
96906	MS35207-264		5305-00-989-7435	16	4
				16	8
				16	24
				16	27
96906	MS35207-265		5305-00-993-1848	4	10
				9	4
				10	27
				10	53
				13	1
				22	1
				25	1
				25	1
96906	MS35207-266		5305-00-995-3444	5	9
96906	MS35207-267		5305-00-993-1851	13	23
96906	MS35207-283		5305-00-993-2459	10	38
96906	MS35249-74			10	50
96906	MS35312-10			29	8
96906	MS35335-31		5310-00-596-7693	14	17
96906	MS35335-33		5310-00-209-0786	16	36
96906	MS35338-39		5310-00-543-5060	14	32
				15	18
96906	MS35338-40		5310-00-543-2410	15	6
96906	MS35338-41		5310-00-045-4007	13	20
				24	5
96906	MS35338-42		5310-00-045-3299	4	2
				5	2
				11	6
				13	12
				14	4
				16	15
				17	3
				22	7
				24	2
				24	9
				26	2
				30	2
				30	2
96906	MS35338-43		5310-00-045-3296	1	2
				4	11
				5	10
				9	5
				10	46
				10	54
				12	3
				13	2
				13	24
				14	2
				16	2
				22	2
				96906	MS35338-44
10	49				
21	2				
96906	MS35338-45		5310-00-407-9566	10	2

SECTION IV

TM9-4120-425-14&P

CROSS-REFERENCE INDEXES

CAGEC	PART NUMBER	PART NUMBER INDEX		FIG.	ITEM
			STOCK NUMBER		
96906	MS35338-45		5310-00-407-9566	30	8
96906	MS35338-46			23	2
96906	MS35338-50		5310-00-820-6653	15	27
96906	MS35489-33		5325-00-185-0017	10	9
96906	MS35489-35		5325-00-185-0012	16	26
96906	MS35489-4		5325-00-174-5317	10	8
				13	18
96906	MS35489-51		5325-00-171-6387	28	20
96906	MS35649-222		5310-00-934-9738	14	33
				15	12
96906	MS35649-2252		5310-00-997-1888	21	1
96906	MS35649-282		5310-00-934-9757	17	2
96906	MS35650-3312		5310-00-054-4892	30	7
96906	MS35842-10		4730-00-908-3195	8	1
96906	MS35842-11		4730-00-908-3194	8	13
96906	MS35872-2		4730-00-189-2737	24	14
96906	MS35872-3		4730-00-189-2739	19	4
96906	MS35917-7		4730-00-254-6447	28	11
96906	MS35919-22		4730-01-037-4919	24	15
96906	MS35928-3		4730-00-940-7940	28	9
96906	MS35928-7		4730-01-328-6117	28	14
96906	MS35929-2		4730-00-257-2163	28	5
81343	MS51007-9		5330-00-063-7889	14	43
96906	MS51959-83		5305-00-719-5007	10	47
96906	MS51967-8		5310-00-732-0558	23	1
96906	MS90726-32			30	6
96906	MS91528-1K2B		5355-00-556-0145	15	8
				15	9
81349	M23053/5-104-9		5970-00-088-2975	BULK	8
81349	M23053/5-105-9		5970-00-082-3942	BULK	7
81349	M23053/5-106-9			14	27
				15	24
			5970-00-814-2878	BULK	9
81349	M24308-4-2		5935-00-490-3743	14	34
81349	M24308/4-303		5935-01-470-8413	15	21
81349	M45913/1-4CG5C		5310-00-088-1251	15	4
81349	M45938/1-5		5310-01-011-7989	15	15
81349	M5086/2-10-9			18	1
			6145-00-578-7513	BULK	16
81349	M5086/2-14-9			18	2
			6145-00-578-6604	BULK	17
81349	M5086/2-20-9			18	3
			6145-00-851-8505	BULK	18
80205	NAS1330H08K161L		5310-01-047-9470	10	31
70436	NT141		5310-00-012-0560	11	13
06383	PN10-10R		5940-00-143-4794	18	11
06383	PN14-10R			18	8
06383	PN18-10R		5940-00-143-4771	18	4
87373	P6TUB6			8	3
87373	P8EUB8			8	10
87373	P8TUB8			8	9

SECTION IV

TM9-4120-425-14&P

CROSS-REFERENCE INDEXES

CAGEC	PART NUMBER	PART NUMBER INDEX		FIG.	ITEM
			STOCK NUMBER		
82647	S20490L22-12			13	21
0NY81	S3100-30Q9999CY			16	12
0NY81	S4100-949			16	13
0V5R4	S8450-2			2	11
0V5R4	S9500-CH			12	10
0V5R4	S9500-JBA-01			16	3
0V5R4	S9500-T			12	8
0V5R4	S9500-THEQ			20	6
0V5R4	S9500-10-14			9	14
0V5R4	S9500-10-16			9	16
0V5R4	S9500-1030			4	14
0V5R4	S9500-1031			4	13
0V5R4	S9500-11-35			10	35
0V5R4	S9500-11-37			10	37
0V5R4	S9500-13-22			12	22
0V5R4	S9500-14-11			14	11
0V5R4	S9500-14-37			14	38
0V5R4	S9500-15-25			15	25
0V5R4	S9500-2-15			2	15
0V5R4	S9500-2-16			2	16
0V5R4	S9500-2-18			2	20
0V5R4	S9500-22-4			22	4
0V5R4	S9500-3-10			3	10
0V5R4	S9500-3-4			3	4
0V5R4	S9500-3-7			3	7
0V5R4	S9500-3/8/16LK			29	1
0V5R4	S9500-30-19			30	14
0V5R4	S9500-3543			9	10
				9	11
0V5R4	S9500-4190			15	1
0V5R4	S9500-4190/16			15	23
0V5R4	S9500-4191			15	14
0V5R4	S9500-4192			15	13
0V5R4	S9500-4231-1			2	10
0V5R4	S9500-4258			13	4
0V5R4	S9500-4274			15	19
0V5R4	S9500-4274/2			15	22
0V5R4	S9500-4276CCW			10	4
0V5R4	S9500-4276CW			10	5
0V5R4	S9500-5337			10	42
0V5R4	S9500-5338-1			10	11
0V5R4	S9500-5338-2			10	12
0V5R4	S9500-5864-1			2	9
0V5R4	S9500-5864-2			2	8
81439	S9500-60TX11			13	22
0V5R4	S9500-6080-5			4	4
0V5R4	S9500-6080-5/2			4	6
0V5R4	S9500-6080-5/3			4	7
0V5R4	S9500-6179-1			2	2
0V5R4	S9500-6179-2			2	5
0V5R4	S9500-6180			2	14

SECTION IV

TM9-4120-425-14&P

CROSS-REFERENCE INDEXES

CAGEC	PART NUMBER	PART NUMBER INDEX		FIG.	ITEM
			STOCK NUMBER		
0V5R4	S9500-6282			3	5
0V5R4	S9500-6282/1			3	6
0V5R4	S9500-6314			3	2
0V5R4	S9500-6314-1			3	3
0V5R4	S9500-6316			5	7
0V5R4	S9500-6318			4	3
0V5R4	S9500-6319			12	21
0V5R4	S9500-6327-1			12	13
0V5R4	S9500-6343			22	3
0V5R4	S9500-6345-1			25	5
0V5R4	S9500-6354			9	13
0V5R4	S9500-6355			9	15
0V5R4	S9500-6356			10	34
0V5R4	S9500-6357			10	36
0V5R4	S9500-6358			10	33
0V5R4	S9500-6361			1	4
0V5R4	S9500-6361/1			1	5
0V5R4	S9500-6361/3			1	7
0V5R4	S9500-6361/5			1	8
0V5R4	S9500-6666			30	5
0V5R4	S9500-6667			30	4
0V5R4	S9500-6670			16	7
0V5R4	S9500-6671			9	20
0V5R4	S9500-6695			3	8
0V5R4	S9500-6695-1			3	11
0V5R4	S9500-6696			4	8
0V5R4	S9500-6697			2	6
0V5R4	S9500-6699			2	7
0V5R4	S9500-6700/273			8	2
0V5R4	S9500-6700/275			8	4
0V5R4	S9500-6700/276			8	5
0V5R4	S9500-6700/277			8	6
0V5R4	S9500-6700/278			8	7
0V5R4	S9500-6700/280			8	11
0V5R4	S9500-6700/282			8	12
0V5R4	S9500-6700/292			8	14
0V5R4	S9500-6701			30	21
0V5R4	S9500-6701/77			30	10
0V5R4	S9500-6701/79			30	11
0V5R4	S9500-6701/80			30	12
0V5R4	S9500-6701/81			30	15
0V5R4	S9500-6701/82			30	16
0V5R4	S9500-6701/83			30	17
0V5R4	S9500-6701/84			30	18
0V5R4	S9500-6701/85			30	19
0V5R4	S9500-6701/86			30	20
0V5R4	S9500-6715			22	9
0V5R4	S9500-6715-1			22	10
0V5R4	S9500-6958			2	13
0V5R4	S9500-7548			2	12
0V5R4	S9500-7867			9	7

SECTION IV

TM9-4120-425-14&P

CROSS-REFERENCE INDEXES

CAGEC	PART NUMBER	PART NUMBER INDEX		FIG.	ITEM
			STOCK NUMBER		
0V5R4	S9500-8165-1			29	5
0V5R4	S9500-8165-2			29	6
0V5R4	S9500-8165-3			29	3
0V5R4	S9500-8423			2	18
0V5R4	S9500-8423/1			2	19
0V5R4	S9500-9508			11	10
0V5R4	S9500-9508/1			11	11
0V5R4	S9500-9514			5	11
0V5R4	S9500-9516			10	13
0V5R4	S9500-9516/4			10	19
				10	24
0V5R4	S9500-9516/8			10	17
				10	26
0V5R4	S9500-9517			10	20
0V5R4	S9500-9518			6	3
0V5R4	S9500-9519			7	3
0V5R4	S9500-9520			5	5
0V5R4	S9500-9521			5	6
0V5R4	S9500-9522			6	15
				7	15
0V5R4	S9500-9523			6	10
				7	10
0V5R4	S9500-9523/1			6	11
				7	11
0V5R4	S9500-9524-1			6	8
				7	9
0V5R4	S9500-9525-2			6	9
				7	8
0V5R4	S9500-9528			6	5
				7	5
0V5R4	S9500-9529			6	6
				7	6
0V5R4	S9500-9540			9	25
0V5R4	S9500-9541			9	24
0V5R4	S9500-9542			9	6
0V5R4	S9500-9543			9	12
0V5R4	S9500-9544			10	30
0V5R4	S9500-9548			10	55
0V5R4	S9500-9549			10	43
0V5R4	S9500-9553			10	51
0V5R4	S9500-9554			10	52
0V5R4	S9500-9555			10	10
0V5R4	S9500-9556			23	5
0V5R4	S9500-9560			11	7
0V5R4	S9500-9560/1			11	9
0V5R4	S9500-9918			29	10
0V5R4	S9500-9921			14	22
0V5R4	S9500-9921-2			14	6
0V5R4	S9500-9921-3			14	9
0V5R4	S9500-9923			14	35
0V5R4	S9500-9927			16	29

SECTION IV

TM9-4120-425-14&P

CROSS-REFERENCE INDEXES

CAGEC	PART NUMBER	PART NUMBER INDEX		FIG.	ITEM
			STOCK NUMBER		
0V5R4	S9500-9932			16	9
0V5R4	S9500-9938			16	5
0V5R4	S9500-9939			13	13
0V5R4	S9500-9940			13	25
0V5R4	S9500-9944			24	3
0V5R4	S9500-9954			16	28
0V5R4	S9500-9959			16	32
0V5R4	S9500-9968			12	20
				12	24
0V5R4	S9500-9970			12	15
0V5R4	S9500-9971			12	16
0V5R4	S9540	5935-01-466-8138		24	12
41947	W-4001	4730-00-263-6465		28	8
41947	W-40324	4730-00-818-7778		28	6
41947	W-40363	4730-00-815-5672		28	7
81348	WW-P-471, TY III, STY A			8	15
41947	W02305			25	6
41947	W1327	4730-00-808-7878		28	16
41947	W2017	4730-00-254-6449		28	10
				28	15
41947	W2034	4730-00-254-6447		25	11
41947	W2334	4730-01-328-6117		25	12
41947	W2716	4730-00-471-5663		28	12
41947	W2817	4730-00-813-3192		28	13
14569	ZR46KC-TF5			29	7
81349	ZZ-T-831TYPEVICL ASS6			BULK	15
70255	053			19	3
70436	130-000-3366			11	15
70436	130-032-234	4130-01-098-6649		11	14
97403	13214E3469	5310-00-821-2366		24	10
97403	13214E3789-11	5320-00-882-8385		4	5
97403	13214E3791-2	5320-00-874-4477		10	14
				10	21
97403	13216E6093-2			11	4
97403	13216E6103-1	3110-01-028-6817		6	13
				7	13
97403	13216E6103-2	3110-01-028-6816		6	14
				7	14
97403	13216E6137	5342-01-042-5759		29	4
97403	13216E6155-2	6680-00-778-3914		26	4
97403	13216E6156			26	3
97403	13216E6170			22	13
97403	13216E6215-1	5930-00-190-8730		24	7
97403	13216E6215-3	5930-00-190-8729		24	6
97403	13216E6220-1	5940-01-201-7221		16	23
97403	13216E6221-1	9905-01-348-0495		16	22
97403	13216E6330	4130-00-479-2744		21	3
97403	13216E6360	5365-01-110-7314		30	9
97403	13218E6957			2	3

I-10

SECTION IV

TM9-4120-425-14&P

CROSS-REFERENCE INDEXES

CAGEC	PART NUMBER	PART NUMBER INDEX		FIG.	ITEM
			STOCK NUMBER		
97403	13218E6958			2	4
97403	13219E1032		4130-01-123-9112	4	12
97403	13225E9509		5340-01-475-8943	11	2
97403	13226E5917			13	5
97403	13228E4258-5		4520-01-476-2807	13	6
0V5R4	13228E4258-5-1			13	7
0V4R4	13228E4258-5-2			13	8
0V4R4	13228E4258-5-3			13	9
0V4R4	13228E4258-5-4			13	10
97403	13229E5334		4730-01-475-9640	8	8
30003	1559AS208			14	7
14852	2CY1405E			27	2
70255	200RB-3T3		4810-01-327-7651	20	1
28520	2166		5975-01-362-7144	14	39
14852	3EY1204D			25	3
70255	500RB272VLC			20	3
28193	5221			22	12
75382	602GP-12			16	19
75382	602GP-12MS			16	20
83330	603GP-MS			17	9
83330	603GP-8			17	11
83330	606GP-MS6			17	6
83330	606GP-6			17	5
71389	75-190024-79P			14	30
				14	44
30756	932052			22	5
82866	97132217			4	9
82866	97132219			5	8

CHAPTER 11
SUPPORTING INFORMATION

REFERENCES

0117-00

SCOPE

This appendix lists all forms, field manuals, technical manuals, and miscellaneous publications referenced in this manual.

FORMS

Recommended Changes to DA Publications	DA Form 2028-2
Equipment Inspection and Maintenance Work Sheet	DA Form 2404
Quality Deficiency Report	DA Form 368
Equipment Inspection and Maintenance Work Sheet (Electronic)	DA Form 5988E

FIELD MANUALS

Electric Motor and Generator Repair	FM 20-31
First Aid for Soldiers	FM 21-11

TECHNICAL MANUALS

Hand Portable Fire Extinguishers Approved for Army Users	TB 5-4200-200-10
The Army Maintenance Management System (TAMMS)	DA PAM 738-750
Painting Instructions for Field Use	TM 43-0139
Organizational, Direct Support, and General Support Maintenance	
Repair Parts and Special Tools List	TM 9-4120-425-14&P
Administrative Storage of Equipment	TM 740-90-1
Procedure For Destruction of Equipment to Prevent Enemy Use	TM 750-244-3
Leak Detector, Refrigerant Gas	TM 9-4940-509-14
Environmentally Safe Substances For Use with	
Communications – Electronics	TB43-0135

END OF TASK

INTRODUCTION**The Army Maintenance System MAC**

This introduction provides a general explanation of all maintenance and repair functions authorized at various maintenance levels under the standard Army Maintenance System concept.

The MAC (immediately following the introduction) designates overall authority and responsibility for the performance of maintenance functions on the identified end item or component. The application of the maintenance functions to the end item or component shall be consistent with the capacities and capabilities of the designated maintenance levels, which are shown on the MAC in column (4) as:

Unit – includes two subcolumns, C (operator/crew) and O (unit) maintenance.

Direct Support – includes an F subcolumn.

General Support – includes an H subcolumn.

Depot – includes a D subcolumn.

The tools and test equipment requirements (immediately following the MAC) list the tools and test equipment (both special tools and common tool sets) required for each maintenance function as referenced from the MAC.

The remarks (immediately following the tools and test equipment requirements) contain supplemental instructions and explanatory notes for a particular maintenance function.

MAINTENANCE ALLOCATION CHART FOR 36,000 BTU AIR CONDITIONER – Continued 0118-00

Table 1. MAC for 36,000 BTU Air Conditioner

(1) GROUP NO.	(2) COMPONENT/ ASSEMBLY	(3) MAINTENANCE FUNCTION	(4) MAINTENANCE LEVEL					(5) TOOLS AND EQUIPMENT	(6) REMARKS	
			UNIT		DS	GS	DEPOT			
			C	O	F	H	D			
00	AIR CONDITIONER, HORIZONTAL, COMPACT, 36,000 BTU/HR	Inspect	0.1						A B, F Q, R G O E P	
		Service	0.3	1.0				1		
		Test	0.5	0.5	0.5			1,2		
		Replace		0.5				1		
		Repair		1.5				1,6,7		
		Repair			8.0			1 thru 5		
		Repair				2.0		8,9		
		Adjust			0.2			1		
01	Canvas Cover	Inspect	0.1							
		Repair		0.1				1		
		Replace		0.2				1		
02	Panels and Covers	Inspect	0.1							
		Repair		0.2				1		
		Replace		0.4				1		
03	Evaporator Air Discharge Louver	Inspect	0.1							
		Repair		0.2				1		
		Replace		0.3				1		
		Service		0.1						
04	Evaporator Air Intake Louver	Inspect	0.1							
		Repair		0.2				1	C	
		Replace		0.3				1		
		Service		0.1						
05	Condenser Exhaust Louver	Inspect	0.2							
		Repair		0.8				1		
		Replace		0.5				1		
06	Condensate Drain Assembly	Inspect	0.2							
		Service		0.5						
		Repair		0.5	0.5			1	C	
		Replace		1.2				1		
07	Evaporator Fan Assembly	Inspect		0.3						
		Repair			6.0			1		H
		Replace			6.0			1		
		Test		0.5				1	I	
08	Louver Actuator Cable	Inspect		0.1						
		Repair		1.0				1	C	
		Replace		1.2				1		
		Adjust		1.2				1		

Table 1. MAC for 36,000 BTU Air Conditioner - Continued

(1) GROUP NO.	(2) COMPONENT/ ASSEMBLY	(3) MAINTENANCE FUNCTION	(4) MAINTENANCE LEVEL					(5) TOOLS AND EQUIPMENT	(6) REMARKS	
			UNIT		DS	GS	DEPOT			
			C	O	F	H	D			
09	Remote Control Module and Heater Subassembly	Inspect	0.1							
		Adjust	0.1						L	
		Repair		2.0				1	S	
		Replace		0.5				1		
10	Junction Box Assembly	Test		1.0				1	K	
		Inspect		0.2						
		Repair		0.8				1,6,9	C	
		Replace		0.5				1		
11	Unit Wiring	Test		0.5				1	M	
		Inspect		0.5						
		Repair		2.5				1	C	
		Replace		1.5				1,6,9		
12	Valves, Coils and Refrigeration Components	Test						1		
		Inspect				0.2				
		Test				0.3			1,2	N
		Repair				7.5			1,2	J
13	Compressor	Replace				7.5		1 thru 5		
		Test				1.0			1,2	
		Repair				3.0			1,2	
		Replace				9.0			1 thru 5	
14	Housing	Inspect		0.5				1		
		Service		0.5				1		
		Repair					1.0		1,6,7,8,9	
		Replace					8.0		1,6,7,8,9	

Table 2. Tools and Test Equipment for 36,000 BTU Air Conditioner

TOOL OR TEST EQUIPMENT REF CODE	MAINTENANCE LEVEL	NOMENCLATURE	NATIONAL STOCK NUMBER	TOOL NUMBER
NOTE				
Standard tools and test equipment in the following kits are adequate to accomplish the maintenance functions listed in Table 1.				
1	O, F, H	Tool Kit, General Mechanics	5180-00-699-5273	SC5180-90-CL-N05
2	O, F, H	Tool Kit, Service, Refrigeration Unit	5180-00-596-1474	SC5180-90-CL-N18
3	F	Pump, Vacuum	4310-00-289-5967	
4	F	Nitrogen Regulator	6680-00-503-1327	
5	F	Recovery and Recycle Unit, Refrigerant	4130-01-338-2707	
6	O	Heat Gun	4940-01-042-4855	
7	O, F, H	Rivet Gun	5120-00-508-1588	
8	F, H	Welding Shop, Trailer Mounted	3431-01-090-1231	SC-3431-95-CL-A04
9	O, F, H	Solder Gun Kit	3439-00-930-1638	
10	F, H	Thermometer Set	6685-00-874-5834	
11	O, F, H	Straightened Fin	5120-00-157-2180	
12	F, H	Screwdriver, Cross Tip	5120-01-412-3430	
13	F, H	Key, Socket Head Screw	5120-00-076-1787	

Table 3. Remarks for 36,000 BTU Air Conditioner

Reference Code	Remarks
A	External at C and O maintenance level.
B	Preventive Maintenance Checks and Services (PMCS).
C	Limited to component part replacement at O level maintenance and above.
D	Limited to component part replacement at F level maintenance and above.
E	Limited to housing repair and insulation replacement.
F	Grease lightly.
G	Repair is limited to replacement of component part at O level maintenance (Ventilation Guard, Ventilation Air Filter, Filter Air Conditioning, Condenser Coil Guard, Information Plate, Mist Eliminator, Heating Elements, Heater Cutout Switch, Circuit Breaker, Transformer, and Terminal Boards).
H	Repair is limited to replacement of component part at F level maintenance (Evaporator Fan Scrolls, Evaporator Impeller Fans, Evaporator Motor, and Motor Bracket and Chassis).
I	Test is limited to Evaporator Motor.
J	Repair is limited to replacement of Coils.
K	Test is limited to Temperature Control Thermostat and Mode Selector Switch.
L	Adjust is limited to Remote Control Module, Temperature Control Thermostat and Mode Selector Switch.
M	Test is limited to Relays.
N	Test is limited to Solenoid Valves and Coils.
O	Repair is limited to replacement of component part at F level maintenance (Condenser Fan Motor, Condenser Fan Scrolls, Condenser Impeller Fans, Condenser Fan Braces and Support, Damper Actuator, Ventilation Damper, Dehydrator, Damper Actuator Cylinder, Receiver, Pressure Relief Valve, Accumulator, Pressure Switches, Service Valves, Expansion Valve, Liquid Sight Indicator, Evaporator Coil, Condenser Coil, and Tubing and Fittings).
P	Adjust is limited to Damper Actuator and Damper Actuator Cylinder.
Q	Test at O level maintenance is limited to Heating Elements, Heater Cutout Switch, Condenser Fan Motors, Circuit Breaker, and Transformer.
R	Test at F level maintenance is limited to Dehydrator, Pressure Switches, and Expansion Valve.
S	Repair is limited to replacement of Temperature Control Thermostat and Mode Selector Switch

END OF TASK

INTRODUCTION

Scope

This work package lists COEI and BII for the air conditioner to help you inventory items for safe and efficient operation of the equipment.

General

The COEI and BII information is divided into the following lists:

Components of End Item (COEI). This list is for information purposes only and is not authority to requisition replacements. These items are part of the air conditioner. As part of the end item, these items must be with the end item whenever it is issued or transferred between property accounts. Items of COEI are removed and separately packaged for transportation or shipment only when necessary. Illustrations are furnished to help you find and identify the items.

Basic Issue Items (BII). These essential items are required to place the air conditioner in operation, operate it, and to do emergency repairs. Although shipped separately packaged, BII must be with the air conditioner during operation and when it is transferred between property accounts. Listing these items is your authority to request/requisition them for replacement based on authorization of the end item by the TOE/MTOE. Illustrations are furnished to help you find and identify the items.

Explanation of Columns in the COEI List and BII List

Column (1), Illus Number, gives you the number of the item illustrated.

Column (2), National Stock Number, identifies the stock number of the item to be used for requisitioning purposes.

Column (3), Description, CAGEC, and Part Number, identifies the Federal item name (in all capital letters) followed by a minimum description when needed. The stowage location of COEI and BII is also included in this column. The last line below the description is the CAGEC (Commercial and Government Entity Code) (in parenthesis) and the part number.

Column (4), Usable on Code, gives you a code if the item you need is not the same for different models of equipment. These codes are identified below:

<u>Code</u>	<u>Used on</u>
24P	S9500-36KH-1

Column (5), U/M (Unit of Measure), indicates how the item is issued for the National Stock Number shown in column (2).

Column (6), Qty Rqr, indicates the quantity required.

COMPONENTS OF END ITEM (COEI) LIST

Table 1. Components of End Item List

(1) ILLUS NUMBER	(2) NATIONAL STOCK NUMBER	(3) DESCRIPTION, CAGEC, AND PART NUMBER	(4) USABLE ON CODE	(5) U/M	(6) QTY RQR
		Connector, Electrical 75-190024-79P (71389)		EA	1

BASIC ISSUE ITEMS (BII) LIST

Table 2. Basic Issue Items List

(1) ILLUS NUMBER	(2) NATIONAL STOCK NUMBER	(3) DESCRIPTION, CAGEC, AND PART NUMBER	(4) USABLE ON CODE	(5) U/M	(6) QTY RQR
		Department of the Army Technical Manual: Operator's, Unit, Direct Support and General Support Maintenance Manual, Including Repair Parts and Special Tools List, TM 9- 4120-425-14&P			

END OF TASK

ADDITIONAL AUTHORIZATION LIST (AAL)

0120-00

INTRODUCTION

Scope

This work package lists additional items you are authorized for the support of the air conditioner.

General

This list identifies items that do not have to accompany the air conditioner and that do not have to be turned in with it. These items are all authorized to you by CTA, MTOE, TDA, or JTA.

Explanation of Columns in the AAL

Column (1), National Stock Number, identifies the stock number of the item to be used for requisitioning purposes.

Column (2), Description, CAGEC, and Part Number, identifies the Federal item name (in all capital letters) followed by a minimum description when needed. The last line below the description is the CAGEC (Commercial and Government Entity Code) (in parenthesis) and the part number.

Column (3), Usable On Code, when applicable, gives you a code if the item you need is not the same for different models of equipment.

Column (4), U/M (Unit of Measure), indicates how the item is issued for the National Stock Number shown in column (1).

Column (5), Qty Recm, indicates the quantity recommended.

ADDITIONAL AUTHORIZED LIST ITEMS

Table 1. Additional Authorization List

(1) NATIONAL STOCK NUMBER	(2) DESCRIPTION, CAGEC, AND PART NUMBER	(3) USABLE ON CODE	(4) U/M	(5) QTY RECM

END OF TASK

INTRODUCTION**Scope**

This work package lists expendable and durable items that you will need to operate and maintain the air conditioner. This list is for information only and is not authority to requisition the listed items. These items are authorized to you by CTA 50-970, Expendable/Durable Items (Except Medical, Class V Repair Parts, and Heraldic Items), or CTA8-100, Army Medical Department Expendable/Durable Items.

Explanation of Columns in the Expendable/Durable Items List

Column (1) – Item Number. This number is assigned to the entry in the list and is referenced in the narrative instructions to identify the item (e.g., “Use lubricating oil (Item 25, WP 5230-00)”).

Column (2) – Level. This column includes the lowest level of maintenance that requires the listed item (C=Operator/Crew).

Column (3) – National Stock Number. This is the NSN assigned to the item which you can use to requisition it.

Column (4) – Item Name, Description, Commercial and Government Entity Code (CAGE), and Part Number (P/N). This column provides the other information you need to identify the item.

Column (5) – Unit of Measure (U/M). This code shows the physical measurement or count of an item, such as gallon, dozen, gross, etc.

EXPENDABLE AND DURABLE ITEMS LIST - Continued

0121-00

Table 1. Expendable and Durable Items List

(1) ITEM NUMBER	(2) LEVEL	(3) NATIONAL STOCK NUMBER	(4) ITEM NAME, DESCRIPTION, CAGE, PART NUMBER	(5) U/M
1	O		Silicone Adhesive Sealant, RTV, General, Mil-A-46106, Type I	
2	O		Solder, Lead-Tin, QQ-S-571, Type SN60WRP2	
3	F	3040-00-664-0439	Adhesive, General Purpose, 1 pint container	ea
4	F	6830-00-292-0732	Nitrogen	cy
5	F		Brazing Alloy, Silver, QQ-B-654, Grade O, I, or II	
6	F		Brazing Alloy, Silver, QQ-B-654, Grade III	
7	F	3439-00-640-3713	Flux, Brazing, O-F-499, Type B	
8	F	5350-00-192-5047	Abrasive Cloth	pg
9	C, O, F	7920-00-205-1711	Rags	
10	F	6850-00-837-9927	Monochlorodifluoromethane, Technical: w/cylinder 22 lbs. (Refrigerant-22), BB-F-1421, Type 22 (81348)	cy
11	O, F		Tape PPP-T-60, Type IV, Class I	roll
12	F	6830-00-872-5120	Trichloromonofluoromethane, Technical: w/cylinder 50 lbs. (Refrigerant-11), BB-F-1421, Type II (81348)	
13	F	8030-00-889-3534	Tape, Antiseize, Polytetrafluorethylene, MIL-T-22730, Size I	roll
14	O, F		Lubricating Oil, VV-L-825, Type IV	qt
15	O, F	3439-01-045-7940	Flux, Soldering, Liquid Rosin Base, MIL-F-14256	qt
16	O, F	6850-01-331-3349	Dry Cleaning Solvent, P-D-680 Type III (81348)	5 gal.
17	O		Coater, Air Filter, MIL-L-2104 (81348)	
18	O, H		Adhesive, MMM-A-121	qt
19	H		Cellular Rubber Strips, MIL-R-6130, Type I, Grade A	ft
20	H		Flexible Elestomeric Thermal Insulation (ASTM C 534, Type 2, Sheet)	shts

Table 1. Expendable and Durable Items List - Continued

(1) ITEM NUMBER	(2) LEVEL	(3) NATIONAL STOCK NUMBER	(4) ITEM NAME, DESCRIPTION, CAGE, PART NUMBER	(5) U/M
21	O, F		Solder, Silver, QQ-S-561, Type 3, 4 or 6A	
22	H		Acetone	pt
23	O, F		Insulation, Sheet, Cellular, MIL-I-14511	
24	O, F		Plastic Foam, Unicellular, Sheet Form, MIL-P-15280	
25	O, F		Adhesive, MMM-A-132, Type I, Class I	
26	F		Industrial Sealant 800	
27	O, F		Acid Swab Brush	
28	F	9150-00-985-7316	Grease, General Purpose	
29	O, F, H	4240-01-152-3555	Mask, Air Filtering	pkg

END OF TASK

INTRODUCTION**Scope**

This work package describes the wiring provisions contained in the air conditioner, including all systems or equipment which can be installed or removed later (e.g., mission-related systems/equipment). A schematic diagram and essential wiring information are provided for all electrical and electronic systems and circuits. All critical wire data has been included.

SCHEMATIC DIAGRAM

A schematic diagram has been included for all electrical and electronic systems and circuits. (Refer to Figure 1, Sheet 1, Schematic Diagram.)

WIRE AND COMPONENT IDENTIFICATION

All wires have been identified by point-to-point wire termination on WP 0101-00 RPSTL Figure 18. A tabular list of circuit designators and their components are shown on Figure 1, Sheet 2, Schematic Diagram Legend.

ABBREVIATIONS

All abbreviations are in accordance with MIL-STD-12, except when the abbreviation stands for a marking actually found in the air conditioner.

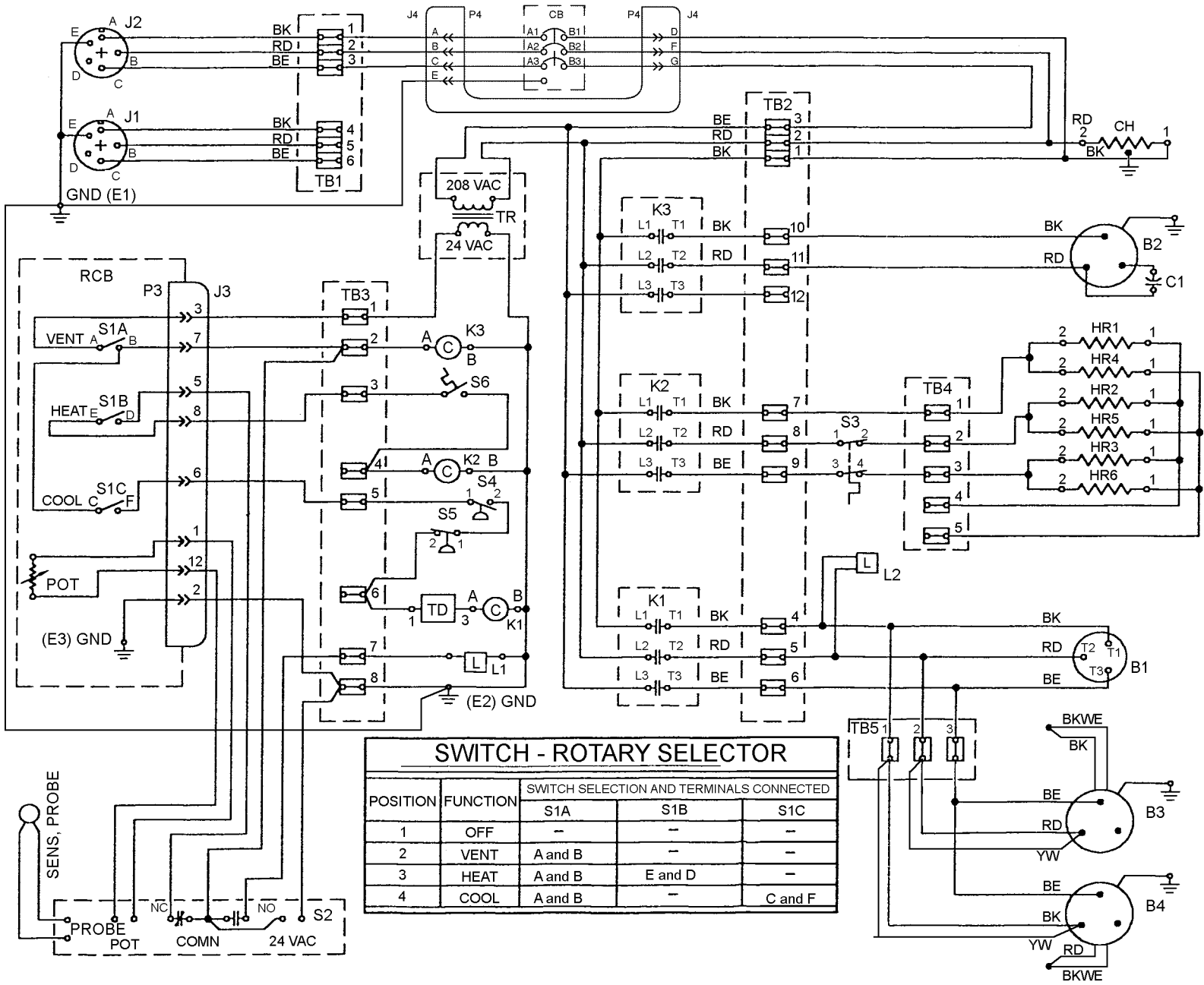

Figure 1. Schematic Diagram (Sheet 1 of 2)

LEGEND	
B1	COMPRESSOR – SCROLL TYPE
B2	MOTOR – EVAPORATOR
B3	MOTOR – R.H. CONDENSER
B4	MOTOR – L.H. CONDENSER
C1	CAPACITOR – EVAPORATOR RUN
C2	CAPACITOR – CONDENSER RUN
C3	CAPACITOR – CONDENSER RUN
CB	CIRCUIT BREAKER – MAIN POWER
CH	CRANKCASE HEATER
HR1 THRU HR6	HEATER ELEMENTS (6 TOTAL)
J1	CONNECTOR POWER RECEPTACLE - REAR
J2	CONNECTOR POWER RECEPTACLE - FRONT
J3	CONNECTOR REMOTE CONTROL BOX – FEMALE PLUG
K1	RELAY – COMPRESSOR MOTOR & CONDENSER MOTORS
K2	RELAY - HEATERS
K3	RELAY – EVAPORATOR FAN MOTOR
L1	SOLENOID VALVE – LIQUID (N.C.)
L2	SOLENOID VALVE – EQUALIZATION (N.O.)
P3	CONNECTOR REMOTE CONTROL BOX – MALE PLUG
RCB	REMOTE CONTROL BOX
S1	SWITCH – ROTARY SELECTOR
S2	SWITCH – TEMPERATURE CONTROL - ELECTRONIC
S3	SWITCH – HEATER CUT-OUT – HIGH VOLTAGE
S4	SWITCH – LOW PRESSURE CUT-OUT
S5	SWITCH – HIGH PRESSURE CUT-OUT
S6	SWITCH – HEATER CUT-OUT LOW VOLTAGE
TB 1	TERMINAL BOARD – POWER INPUT
TB 2	TERMINAL BOARD – HIGH VOLTAGE
TB 3	TERMINAL BOARD – LOW VOLTAGE
TB 4	TERMINAL BOARD – ELECTRIC HEATERS
TB 5	TERMINAL BOARD – CONDENSER MOTORS
TD	TIME DELAY DEVICE – COMPRESSOR CONTROL
TR	TRANSFORMER – 24 V AC CONTROL POWER

Figure 1. Legend – Schematic Diagram (Sheet 2 of 2)

END OF TASK

CHAPTER 12
REAR MATTER

ALPHABETICAL INDEX

	<u>WP Sequence No.</u>
Accumulator Direct Support Maintenance Replacement	0071-00
Accumulator	0106-00
Additional Authorization List (AAL).....	0120-00
Air Conditioner Control and Indicators.....	0005-00
Air Conditioner Operation Under Unusual Conditions	0007-00
Air Conditioner Operation Under Usual Conditions	0006-00
Bulk Materials List	0114-00
Canvas Cover – Services	0018-00
Canvas Cover	0084-00
Circuit Breaker – Unit Maintenance.....	0033-00
Circuit Breaker	0097-00
Coil (Solenoid Valve) – Unit Maintenance	0039-00
Compact, 36,000 BTU/HR, 208 Volt, Three Phase, 50/60 Hertz.....	0083-00
Component of End Item (COEI) and Basic Issue Items (BII) Lists	0119-00
Compressor Direct Support Maintenance Replacement	0076-00
Compressor.....	0112-00
Condensate Drain Assembly – Unit Maintenance.....	0029-00
Condensate Drain Assembly Direct Support Maintenance	0056-00
Condensate Drain	0091-00
Condenser Air Discharge Louvers – Unit Maintenance	0021-00
Condenser Air Exhaust Louver Assembly (Left)	0089-00
Condenser Air Exhaust Louver Assembly (Right).....	0090-00
Condenser Coil – Unit Service	0041-00
Condenser Coil Direct Support Maintenance Replacement	0078-00
Condenser Coil Guard – Unit Maintenance.....	0024-00
Condenser Coil	0110-00
Condenser Exhaust Louvers, Condenser Coil Guard, Ventilation Air Filter and Guard	0088-00
Condenser Fan Motors – Unit Maintenance	0031-00
Condenser Fan Scrolls Direct Support Maintenance Replacement	0063-00
Condenser Fan Support Direct Support Maintenance Replacement.....	0064-00
Condenser Fan	0093-00
Condenser Impeller Fans and Motors Direct Support Maintenance Replacement	0062-00
Damper Actuator Cylinder Direct Support Maintenance Replacement.....	0068-00
Damper Actuator Cylinder	0104-00
Dehydrator (Filter-Drier) Direct Support Maintenance Replacement	0066-00
Dehydrator (Filter-Drier).....	0102-00
Direct Support Malfunction/System Index.....	0046-00
Direct Support Troubleshooting Introduction	0045-00
Direct Support Troubleshooting Procedures	0047-00
Evaporator Air Intake Filter – Unit Maintenance.....	0023-00
Evaporator Air Louvers, Air Conditioning Filter and Mist Eliminator	0087-00
Evaporator Coil – Unit Service	0040-00
Evaporator Coil and Expansion Valve	0108-00
Evaporator Coil Direct Support Maintenance Replacement.....	0077-00
Evaporator Fan Assembly Direct Support Maintenance	0057-00
Evaporator Fan Assembly	0092-00
Evaporator Fan Motor – Unit Maintenance.....	0030-00
Evaporator Fan Motor Direct Support Maintenance Replacement.....	0060-00
Evaporator Fan Scrolls Direct Support Maintenance Replacement.....	0059-00

ALPHABETICAL INDEX - Continued

	<u>WP Sequence No.</u>
Evaporator Impeller Fans Direct Support Maintenance Replacement.....	0058-00
Evaporator Louvers – Unit Maintenance.....	0020-00
Evaporator Motor Bracket and Chassis Direct Support Maintenance Replacement	0061-00
Expansion Valve Direct Support Maintenance Replacement.....	0074-00
Expendable and Durable Items List.....	0121-00
Frontispiece – Air Conditioner, Horizontal, General Information	0001-00
Description and Data	0002-00
General Support Maintenance	0080-00
Heater Cutout Switches – Unit Maintenance.....	0027-00
Heater Subassembly – Unit Maintenance.....	0028-00
Heater Subassembly	0096-00
Housing – Unit Service	0042-00
Housing General Support Maintenance.....	0081-00
Housing	0113-00
Identification Plates.....	0085-00
Information Plates – Unit Maintenance.....	0025-00
Installation Hardware – Unit Maintenance.....	0044-00
Introduction	0082-00
Junction Box Assembly – Unit Maintenance	0035-00
Junction Box.....	0099-00
Liquid Sight Indicator Direct Support Maintenance Replacement.....	0075-00
Liquid Sight Indicator.....	0109-00
Louver Actuator Cables – Unit Maintenance.....	0032-00
Louver Actuator Cables.....	0094-00
Main Power Input Connector – Unit Maintenance.....	0043-00
Maintenance Allocation Chart For 36,000 BTU Air Conditioner	0118-00
Mist Eliminator – Unit Maintenance.....	0026-00
National Stock Number Index	0115-00
Operator Maintenance Instructions	0012-00
Operator Malfunction/Symptom Index.....	0009-00
Operator Preventive Maintenance Checks and Services	0011-00
Operator Troubleshooting Introduction.....	0008-00
Operator Troubleshooting Procedures.....	0010-00
Panels – Unit Maintenance.....	0019-00
Panels and Covers	0086-00
Part Number Index	0116-00
Pressure Relief Valve Direct Support Maintenance Replacement.....	0070-00
Pressure Switches and Service Valves	0107-00
Pressure Switches Direct Support Maintenance Replacement	0072-00
Receiver and Pressure Relief Valve	0105-00
Receiver Direct Support Maintenance Replacement.....	0069-00
References	0117-00
Refrigeration System Description	0048-00
Refrigeration System Servicing – (Brazing/Debrazing).....	0051-00
Refrigeration System Servicing – (Charging)	0054-00
Refrigeration System Servicing – (Discharging).....	0049-00
Refrigeration System Servicing – (Evacuation)	0053-00
Refrigeration System Servicing – (Leak Test).....	0052-00

ALPHABETICAL INDEX - Continued

	<u>WP Sequence No.</u>
Refrigeration System Servicing – (Pressure Testing).....	0055-00
Refrigeration System Servicing – (Purging).....	0050-00
Remote Control Module – Unit Maintenance	0034-00
Remote Control Module.....	0098-00
Schematic Diagram	0122-00
Service Valves Direct Support Maintenance Replacement	0073-00
Solenoid Valves and Hot Gas By-Pass Valve Direct Support Maintenance Replacement.....	0067-00
Solenoid Valves.....	0103-00
Supporting Data for Repair Parts, Special Tools, TMDE, and Support Equipment.....	0004-00
Terminal Boards TB1 and TB5 – Unit Maintenance.....	0037-00
Terminal Boards.....	0100-00
Theory of Operation	0003-00
Transformer – Unit Maintenance	0036-00
Tubing and Fittings Direct Support Maintenance Replacement.....	0079-00
Tubing and Fittings	0111-00
Unit Maintenance Mechanical Repairs and Electrical Repairs.....	0017-00
Unit Maintenance Service Upon Receipt	0015-00
Unit Preventive Maintenance Checks and Services (PMCS)	0016-00
Unit Troubleshooting Introduction.....	0013-00
Unit Troubleshooting.....	0014-00
Unit Wiring – Unit Maintenance.....	0038-00
Unit Wiring.....	0101-00
Ventilation Damper Direct Support Maintenance	0065-00
Ventilation Damper.....	0095-00
Ventilation Guard and Ventilation Air Filter – Unit Maintenance.....	0022-00

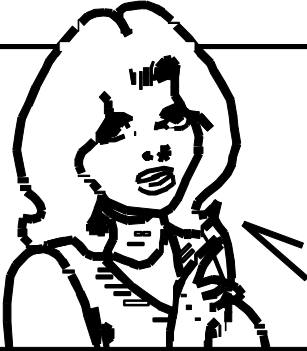

SOMETHING WRONG WITH THIS PUBLICATION

THEN ... JOT DOWN THE INFO ABOUT IT ON THIS FORM. CAREFULLY TEAR IT OUT. FOLD IT AND DROP IT IN THE MAIL.

FROM: (PRINT YOUR UNIT'S COMPLETE ADDRESS)
 Commander
 Stateside Army Depot
 ATTN: AMSTA-US
 Stateside, N.J. 07703-5007

DATE SENT
 10 July 1975

PUBLICATION NUMBER TM 11-5840-340-20	PUBLICATION DATE 23 Jan 74	PUBLICATION TITLE Radar Set AN/PRC-76
---	-------------------------------	--

BE EXACT PIN-POINT WHERE IT IS				IN THIS SPACE TELL WHAT IS WRONG AND WHAT SHOULD BE DONE ABOUT IT:
PAGE NO	PARA GRAPH	FIGURE NO	TABLE NO	
2-25	2-28			<p>Recommend that the installation antenna alignment procedure be changed throughout to specify a 20 IFF antenna lag rather than 10.</p> <p>REASON: Experience has shown that with only a 10 lag, the antenna servo system is too sensitive to wind gusting in excess of 25 knots, and has a tendency to rapidly accelerate and decelerate as it hunts, causing strain to the drive train. Hunting is minimized by adjusting the lag to 20 without degradation of operation.</p>
3-10	3-3		3-1	<p>Item 5, Functional column. Change • 2 dB" to • 3 dB".</p> <p>REASON: The adjustment procedure for the TRANS POWER FAULT indicator calls for a 3 dB (500 watts) adjustment to light the TRANS POWER FAULT indicator.</p>
5-6	5-8			<p>Add new step f.1 to read, • Replace cover plate removed in step f.1, above."</p> <p>REASON: To replace the cover plate.</p>
		FO-3		<p>Zone C 3. On J1-2, change • +24 VDC" to • +5 VDC".</p> <p>REASON: This is the output line of the 5 VDC power supply. +24 VDC is the input voltage.</p>

TEAR ALONG DOTTED LINE

PRINTED NAME, GRADE OR TITLE AND TELEPHONE NUMBER SSG I. M. DeSpirito 999-1776	SIGN HERE
---	---------------

FILL IN YOUR
UNIT'S ADDRESS

FOLD BACK

DEPARTMENT OF THE ARMY

OFFICIAL BUSINESS

PLEASE
AFFIX
STAMP
POSTAGE
REQUIRED

SAMPLE

Commander
U.S. Army Communications-Electronics Command
and Fort Monmouth
ATTN: AMSEL-LC-LEO-D-CS-CFO
Fort Monmouth, New Jersey 07703-5006

TEAR ALONG DOTTED LINE

SOMETHING WRONG WITH THIS PUBLICATION

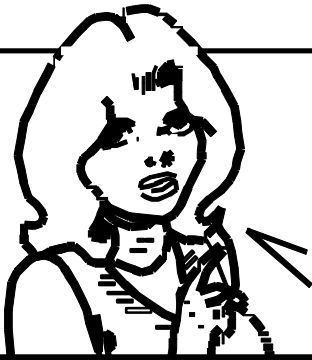

THEN ... JOT DOWN THE INFO ABOUT IT ON THIS FORM. CAREFULLY TEAR IT OUT. FOLD IT AND DROP IT IN THE MAIL.

FROM: (PRINT YOUR UNIT'S COMPLETE ADDRESS)

DATE SENT

PUBLICATION NUMBER

PUBLICATION DATE

PUBLICATION TITLE

BE EXACT PIN-POINT WHERE IT IS

IN THIS SPACE TELL WHAT IS WRONG AND WHAT SHOULD BE DONE ABOUT IT:

PAGE NO

PARA GRAPH

FIGURE NO

TABLE NO

TEAR ALONG DOTTED LINE

PRINTED NAME, GRADE OR TITLE AND TELEPHONE NUMBER

SIGN HERE

FILL IN YOUR
UNIT'S ADDRESS

FOLD BACK

DEPARTMENT OF THE ARMY



OFFICIAL BUSINESS

PLEASE
AFFIX
STAMP
POSTAGE
REQUIRED

TEAR ALONG DOTTED LINE

Commander
U.S. Army Communications-Electronics Command
and Fort Monmouth
ATTN: AMSEL-LC-LEO-D-CS-CFO
Fort Monmouth, New Jersey 07703-5006

SOMETHING WRONG WITH THIS PUBLICATION



THEN ... JOT DOWN THE INFO ABOUT IT ON THIS FORM. CAREFULLY TEAR IT OUT. FOLD IT AND DROP IT IN THE MAIL.

FROM: (PRINT YOUR UNIT'S COMPLETE ADDRESS)

DATE SENT

PUBLICATION NUMBER

PUBLICATION DATE

PUBLICATION TITLE

BE EXACT PIN-POINT WHERE IT IS

IN THIS SPACE TELL WHAT IS WRONG AND WHAT SHOULD BE DONE ABOUT IT:

PAGE NO

PARA GRAPH

FIGURE NO

TABLE NO

TEAR ALONG DOTTED LINE

PRINTED NAME, GRADE OR TITLE AND TELEPHONE NUMBER

SIGN HERE

FILL IN YOUR
UNIT'S ADDRESS

FOLD BACK

DEPARTMENT OF THE ARMY

OFFICIAL BUSINESS

PLEASE
AFFIX
STAMP
POSTAGE
REQUIRED

TEAR ALONG DOTTED LINE

Commander
U.S. Army Communications-Electronics Command
and Fort Monmouth
ATTN: AMSEL-LC-LEO-D-CS-CFO
Fort Monmouth, New Jersey 07703-5006

SOMETHING WRONG WITH THIS PUBLICATION

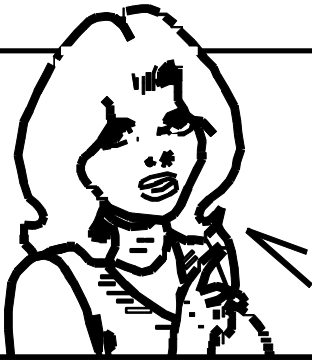

THEN ... JOT DOWN THE INFO ABOUT IT ON THIS FORM. CAREFULLY TEAR IT OUT. FOLD IT AND DROP IT IN THE MAIL.

FROM: (PRINT YOUR UNIT'S COMPLETE ADDRESS)

DATE SENT

PUBLICATION NUMBER

PUBLICATION DATE

PUBLICATION TITLE

BE EXACT PIN-POINT WHERE IT IS

IN THIS SPACE TELL WHAT IS WRONG AND WHAT SHOULD BE DONE ABOUT IT:

PAGE NO

PARA GRAPH

FIGURE NO

TABLE NO

TEAR ALONG DOTTED LINE

PRINTED NAME, GRADE OR TITLE AND TELEPHONE NUMBER

SIGN HERE

FILL IN YOUR
UNIT'S ADDRESS

FOLD BACK

DEPARTMENT OF THE ARMY

OFFICIAL BUSINESS

PLEASE
AFFIX
STAMP
POSTAGE
REQUIRED

TEAR ALONG DOTTED LINE

Commander
U.S. Army Communications-Electronics Command
and Fort Monmouth
ATTN: AMSEL-LC-LEO-D-CS-CFO
Fort Monmouth, New Jersey 07703-5006

By Order of the Secretary of the Army:

Official:

JOEL B. HUDSON
*Administrative Assistant to the
Secretary of the Army*
0225601

ERIC K. SHINSEKI
*General, United States Army
Chief of Staff*

DISTRIBUTION:

To be distributed in accordance with the initial distribution number (IDN) 344755 requirements for TM 9-4120-425-14&P.

